

AMAZING MACHINERY

The Pressure Washer People 800-504-7435



OPERATOR'S MANUAL

JETTER TRAILER/PRESSURE WASHER COMBO
Gas & Diesel Engine Models

READ THIS MANUAL

This manual contains important information for the use and safe operation of your AMAZING MACHINERY™ machine. **FAILURE TO READ THIS MANUAL AND FOLLOW ITS INSTRUCTIONS PRIOR TO OPERATING OR ATTEMPTING ANY SERVICE OR MAINTENANCE PROCEDURE COULD RESULT IN SERIOUS INJURY OR DEATH TO YOU OR OTHER PERSONS; ALSO DAMAGE TO THE MACHINE OR TO OTHER PROPERTY.**

Table of Contents

SECTION 1 OPERATOR'S MANUAL

- UNPACKING.....2
- SAFETY INSTRUCTIONS AND WARNINGS.....3
- MAINTENANCE INSTRUCTIONS.....4

SECTION 2 PARTS AND SERVICE MANUAL

- OPERATING INSTRUCTIONS.....5
- IMPORTANT INFORMATION.....6
- JETTER SETUP.....7
- PRESSURE WASHER SETUP.....8
- WINTERIZING MACHINERY.....9
- PLUMBING DIAGRAMS.....10
- HOSE, WAND, & GUN.....11
- BELT DRIVEN PUMP.....11
- WIRING DIAGRAM.....12
- TROUBLESHOOTING.....13
- WARRANTY.....14

Unpacking Instructions

INSPECTION

Carefully unpack your new AMAZING MACHINERY equipment by removing the shrink wrap & banding from pallet. Remove the pressure washer from the pallet and check for any physical damages that may have occurred during shipment. Check for all parts specified and shown in figure 1.



INCLUDED PARTS

- Pallet
- Packing Material
- Outer Crate
- JETTER/PRESSURE WASHER COMBO Trailer Unit
- Jetter & PW Accessories
- Certificate of Origin
- Operator's Manual

Figure 1

NOTICE

Information in this operator's manual is subject to change without notice.

AMAZING MACHINERY SHALL NOT BE LIABLE FOR TECHNICAL OR EDITORIAL ERRORS OR OMISSIONS CONTAINED HEREIN. This operator's manual contains information protected by copyright. No part of this operator's manual may be photocopied or reproduced in any form without prior written consent from AMAZING MACHINERY.

© AMAZING MACHINERY, 2006
All rights reserved. Printed in USA.

First Printing (February 2006)

Safety Guidelines



READ THIS FIRST! FAILURE TO READ AND OBSERVE ALL WARNING STATEMENTS COULD RESULT IN SEVERE BODILY INJURY OR DEATH, POSSIBLE INJURY TO OTHER PERSONS, DAMAGE TO MACHINE OR OTHER PROPERTY.

- DO NOT operate this machine in areas where open flames are not permitted. DO NOT store or use combustible materials on or near this machine. Use this equipment only in well ventilated areas. Failure to follow this warning may cause carbon monoxide build up, fire or explosion, and possible injury or death.
- DO NOT fill gasoline tank while engine is running. Allow engine to cool before refueling. Should gasoline be spilled, move the machine away from the area of the spill. Do not attempt to restart the machine until the gasoline has fully evaporated.
- DO NOT operate engine if air cleaner or cover directly over the carburetor air intake is removed.
- DO NOT touch hot mufflers, cylinders or fins, as contact may cause burns
- DO NOT operate this machine while under the influence of alcohol, drugs or while fatigued.
- DO NOT direct discharge stream at yourself or others. Risk of injection or injury may occur. Never put your hand or fingers over the spray tip. Do not try to stop or deflect leaks with your hand or body. Always face nozzle and wand to the ground when testing.
- DO NOT operate this machine WITHOUT wearing protective Eye Wear. Gloves, Hard Hat, Mask, Ear Plugs & Steel Toe Work Boots are also recommended, DO NOT wear loose clothing. Keep your body and clothing clear of the engine and discharge stream when the machine is running.
- DO NOT tie back or block trigger gun in OPEN position. Never leave the pressure washer unattended once you have started it. If you leave, shut down machine completely.
- DO NOT overreach or stand on an unstable support while operating this machine. Maintain good footing and balance.
- DO NOT permit this machine to run while unattended or for extended periods of time with trigger gun closed. Damage to pump may occur.
- DO NOT operate this machine in an unsafe manner or around unsupervised children. Keep all other personnel clear while operating this machine. This product should only be operated by trained personnel.
- DO NOT alter original factory settings prior to operating this machine. Risk of injury to yourself or other persons may occur.
- DO NOT remove hoses, guns, nozzles or any components while this machine is still hot or while it is running.
- DO NOT attempt to service this machine before reading the service manual.
- DO NOT use water with a temperature over 140 degrees Fahrenheit
- DO NOT operate this machine without knowing how to stop and bleed water pressures. Know all controls before using this machine.
- DO NOT spray caustic, acids or abrasive fluids through this machine.
- DO NOT permit water to freeze inside this machine. Pump and plumbing damage may occur.
- Use only recommended AMAZING MACHINERY™ parts when servicing this machine.
- AMAZING MACHINERY™ will not be held liable for any unauthorized modifications made to this machine. Any such action will void the warranty.
- Although the trailer has been engineered to carry the full weight of the the equipment plus a full water tank, AMAZING MACHINERY™ recommends that the trailer only be towed with an empty tank. Failure do do so may violate state and local law; AMAZING MACHINERY is not liable for any accidental damage or fines incurred in such a situation.
- When connecting battery, ensure that the RED battery cable is connected to the POSITIVE pole on the battery and the BLACK is connected to the NEGATIVE pole on the battery.

Maintenance Instructions

MOVING, STORAGE

- Place machine in covered area when not in use to protect from elements. Protect machine from freezing in cold temperatures by storing in a heated location.

TRAILER MAINTENANCE

- Daily: Check wheel bearings. Add grease if necessary.
- Daily: Check tires for proper inflation.
- Daily: Check trailer for loose equipment. Tighten if necessary.

ENGINE MAINTENANCE

- Every time (before start): Check oil level.
- First 8 hours: Change oil with **SAE 30W High-Detergent Oil**.
- Every 25 hours: Change oil if operating under heavy load or high ambient temperature. Service air cleaner pre-cleaner.
- Every 50 hours: Change oil. Clean and inspect spark arrester if equipped.
- Every 100 hours: Service air cleaner cartridge, replace oil filter (if equipped), Clean oil cooler (if equipped), Clean cooling system.

PUMP MAINTENANCE

- Fill crankcase to dot on oil gauge window per specifications with the specific oil created by the pump manufacturer (i.e. **General Pump Oil**). Ensure the right oil for specific pump as it may vary.
- Change oil after **25 Hour Break-in Period**.
- Change oil every **Three Months or at 100 Hour Intervals** thereafter.

UNLOADER ADJUSTMENT

- Changing Operating Pressure: This unit is equipped with a black knob on the side of the pump. By turning the black knob clockwise, you can raise the operating pressure up to the maximum output. By turning the knob counterclockwise, you can reduce the operating pressure as low as 500 PSI.
- It is recommended that the black knob **should not be removed** in an attempt to permanently set the unloader pressure.

Operating Instructions

LOCATION GUIDELINES

- Locate the machine on a solid and level surface so that engine and pump crankcase oil lubricate components properly. Avoid areas where water can build up in the working area. Possible injury can occur caused by the surface becoming slippery from water build up.
- Locate the machine in a well-ventilated area and away from flammable materials or fumes. Be sure ventilation warnings are observed. Keep pressure washer at least 18" away from flammable materials.
- Locate the machine so the operator has easy access to the jetter/pressure washer and its controls. Locate the machine so that it is protected from external damage.
- To prevent damage and excessive hose wear, locate the unit so that the hose does not cross traffic areas.

STARTING THE MACHINE

Following the steps below will insure successful operation:

- Read this manual completely before attempting to start the machine.
- Check the fuel tank and fill with a good grade of gasoline (87 octane minimum) for gas engines and a high quality diesel fuel for diesel engines.
- Check the engine oil level and fill with SAE 30 weight *high-detergent* oil.
- Check the pump oil level and fill with SAE 30w *non-detergent* oil if needed.
- Check water tank to ensure adequate level of water required for the job.

- **For Jetting, procede to page #7: Jetting Setup Page .**
- **For Presuure Washing , procede to page #8: Pressure Washing Setup Page.**

- Pull trigger on gun until a steady stream of water comes out the nozzle. This purges any air in the system.
- Slide fuel switch to the RIGHT and slide choke switch to the LEFT (closed position).
- Turn ON/OFF switch (on engine) to "ON".
- Open water flow to reduce back pressure in pump. Back pressure can overpower electric starter, preventing ignition.
- Turn key to start gas engine and allow RPM to develop.
- Let engine warm up for approximately 30 seconds and slide choke to "OPEN" position.
- Check for leaks in the system and cycle trigger gun to insure bypass is adjusted correctly. Repair any leaks and correct unloader adjustment if needed. Turn off machine before attempting any repairs.
- **WARNING - Do not operate machine with less than 6" of water in the tank. Doing so may cause pump damage!**

STOPPING THE MACHINE

- Turn engine to "OFF".
- Pull gun trigger to release water pressure from system.
- Disconnect wand & gun assembly.
- Wind up pressure hose on hose reel.

CAUTION

- Always wear protective safety gear, such as, but not limited to, rain coat or coveralls, rubber boots, face shield or goggles, gloves and hearing protection.
- Never start the machine with the jetter nozzle outside the drain.
- Do not remove the jetter nozzle from the drain while the unit is under pressure.
- Do not run the machine for more than two minutes with the jetter water flow shut off (by-pass mode). This will over heat the jetter pump and could cause injury to you.
- To start the water flow, step on the foot valve easily or open the ball valve slowly for a smooth start up.
- This machine is not designed to be used with hot water. Jetting with hot water is very dangerous.

IMPORTANT INFORMATION

Special Techniques

- The jetter nozzles are designed to draw the sewer hose into the line. However in some cases you will need to rotate or move the hose in and out to get it through and around clogs or around corners. There is a little art to this, you will understand after jetting a few times.
- It is best to jetter from the low end of the line so the water can drain out as you go. If you are jetting from the high end of the line you may have to stop occasionally to allow the accumulated water to drain past the jetter nozzle.

Pulse Control

- The pulse control handle is located on the face of the pump, by turning the handle to the left you get a steady stream of water to be used with the pressure washer gun and tips or the Laser sewer nozzle.
- By turning the handle to the right, you get a pulse water flow to be used with the Ram sewer nozzle.
- Sewer hose to line size is important. Use the proper size hose in relationship to size of the line you are cleaning so that the hose will feed and go around corners properly without doubling back on you.
- 3/8" hose should be used with 4" to 16" lines

Sewer Nozzles – What They Do

It's important to use the correct nozzle to get the job done properly.

- Ram Nozzle – used with pulse water to beat out blockage.
- Laser Nozzle – used with constant water to cut out blockage.

Septic tank and Man Hole Entrances

To help reach line entrances in septic tanks and man holes, you can use a piece of 2" PVC pipe with a 45 angle on the end. Make it long enough to put the 45 into the line entrance while you stand on top. Then run the jetter hose through the PVC and into the clogged line.

JETTER SETUP

STARTING THE MACHINE

Following the steps below will insure successful operation:

- Turn the optional tank dump ball valve (BV#3) to the "CLOSED" position.
- Connect customer supplied garden hose to water supply and fill tank.
- Turn the pressure washer hose reel ball valve (LV#2) to the "CLOSED" position.
- Make sure antifreeze ball valve (BV#1) is in the "CLOSED" position.
- Turn the main water supply ball valve (BV#2) into the "OPEN" position.
- Turn pulsation valve to pulse or constant position.
- For ball valve water flow jetting operation: connect high pressure hose from machine to jetter hose reel. Use jetter ball valve open/close to control jetter water flow.
- (Optional) Foot valve water flow jetting operation: disconnect high pressure hose at jetter hose reel quick connect. Attach foot valve using quick connects into high pressure line. Open lever valve and use foot valve to control water flow.
- Roll jetter hose onto electric jetter hose reel. Hose should be installed to roll off top of reel.
- Install desired jetter tip.
- Put at least 4 feet of jetter hose into drain line to be cleaned.
- Start engine (see earlier instructions).
- Hold jetter hose with a firm grip.
- Start water flow and set desired pressure.
- Start jetting.

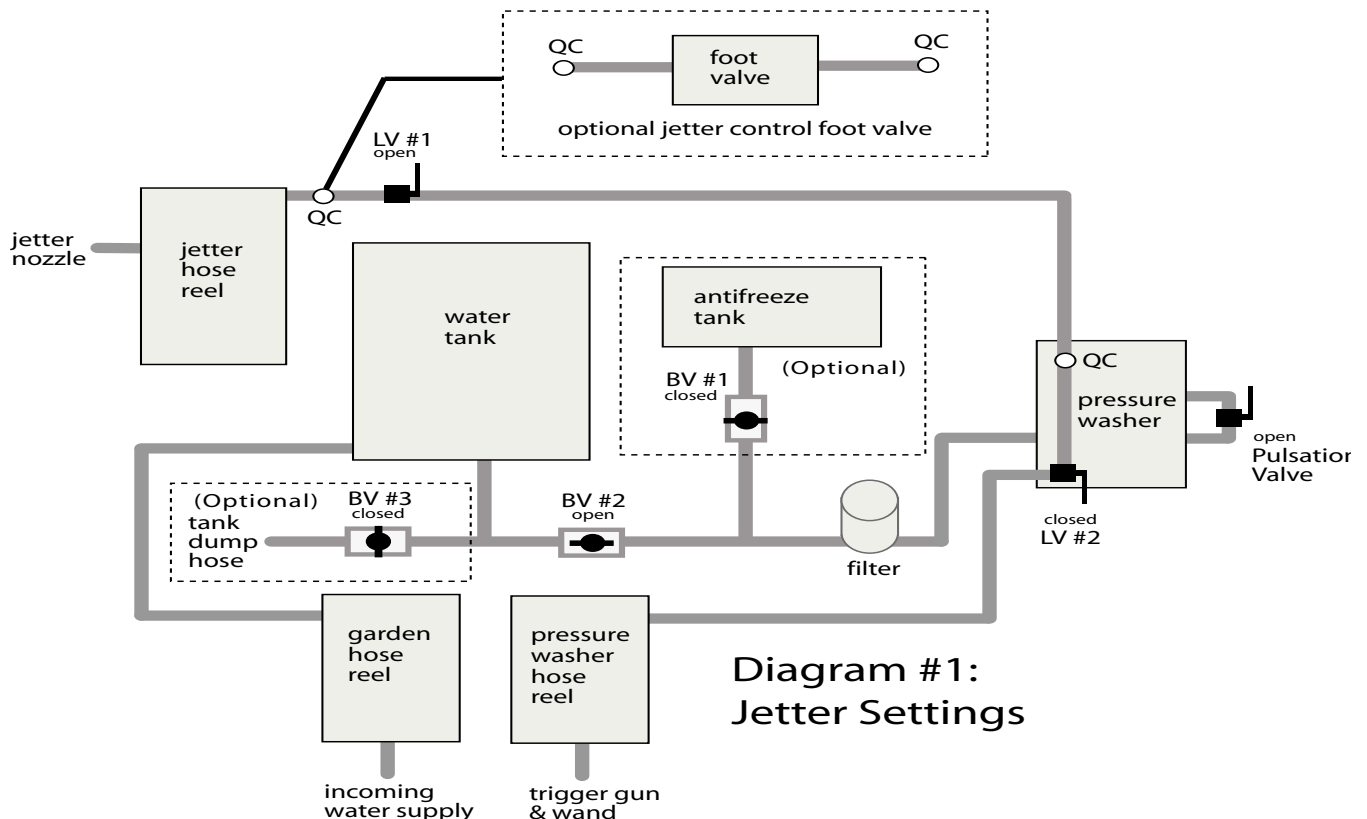

**Diagram #1:
Jetter Settings**

PRESSURE WASHER SETUP

STARTING THE MACHINE

Following the steps below will insure successful operation:

- Turn the (optional) tank dump ball valve (BV#3) to the "CLOSED" position.
- Connect customer supplied garden hose to water supply and fill tank.
- Turn the pressure washer to hose reel lever valve (LV#3) to the "OPEN" position
- Make sure antifreeze ball valve (BV#1) is in the "CLOSED" position.
- Turn the pulsation valve lever to the constant flow position
- Turn the jetter hose reel lever valve (LV#1) to the "CLOSED" position.
- Turn the main water supply ball valve (BV#2) into the "OPEN" position
- Connect gun/wand/tip to end of pressure washer hose at pressure washer hose reel.
- (Optional) Chemical injector can be quick coupled into high pressure line at outport of unloader valve. Use black chemical tip to activate chemical injector.
- Start engine (see earlier instructions).
- Pull trigger gun to start water flow.
- Set desired pressure with black unloader knob located on pump.
- Start pressure washing.

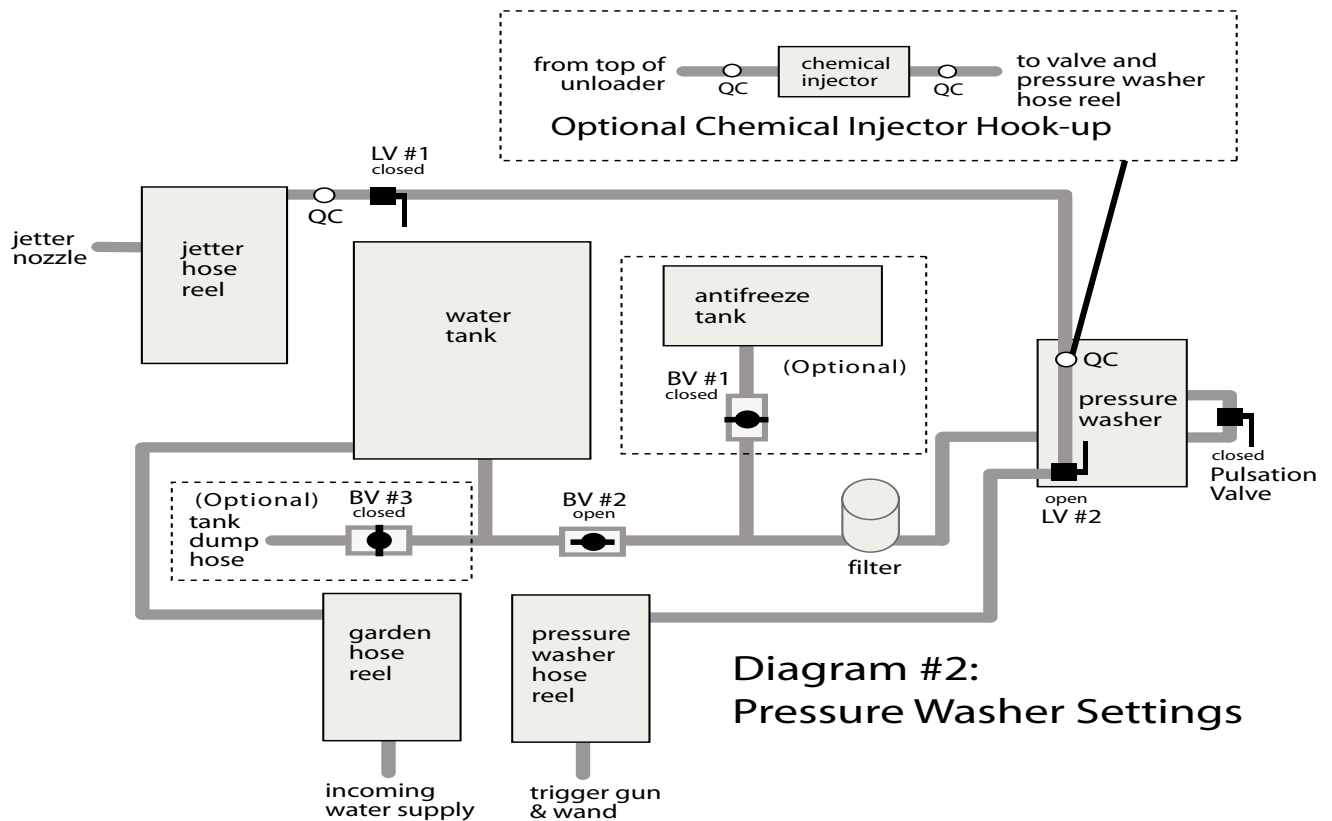

Diagram #2:
Pressure Washer Settings

WINTERIZING MACHINERY

WINTERIZING WITHOUT OPTIONAL ANTIFREEZE KIT

- Run the machine to run all the water out of the tank.
- Ensure tank is empty.
- Pour antifreeze mixture into water tank.
- Make sure all other valves are open.
- Start engine.
- Flow antifreeze thru pump, all lines, and all hose reels, ensuring there is no water left in the system.

WINTERIZING WITH OPTIONAL ANTIFREEZE KIT

- Turn the tank dump ball valve (BV#3) to the "OPEN" position and drain tank.
- After draining, turn ball valves water supply ball valve (BV#2) to the "CLOSED" position
- Ensure there is antifreeze mixture in antifreeze tank.
- Turn the tank antifreeze tank ball valve (BV#1) to the "OPEN" position
- Start engine.
- Flow antifreeze thru pump, all lines, and all hose reels, ensuring there is no water left in the system.

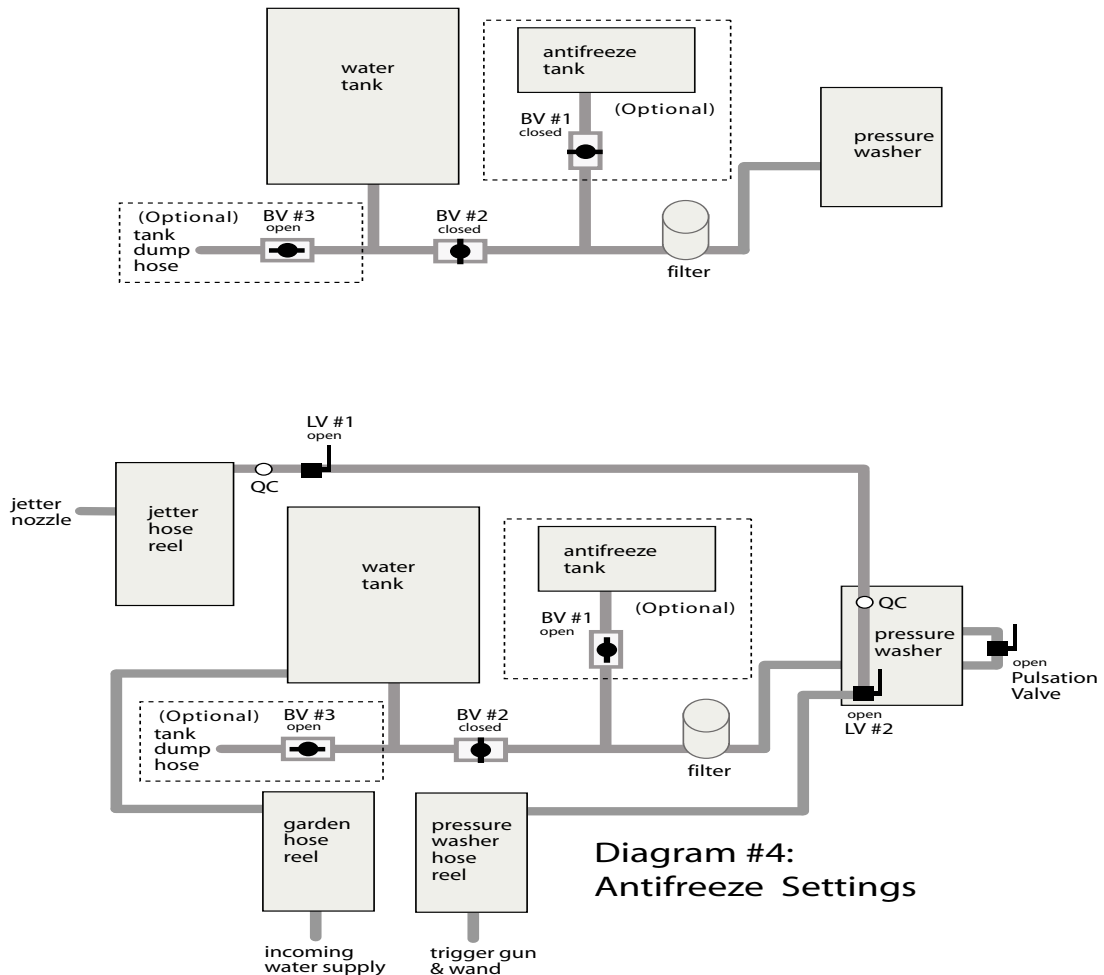

Plumbing Diagrams

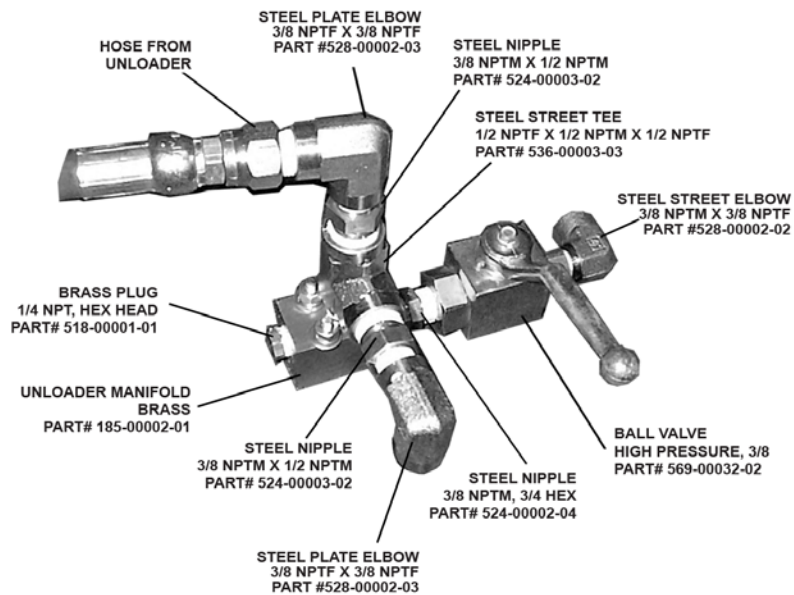
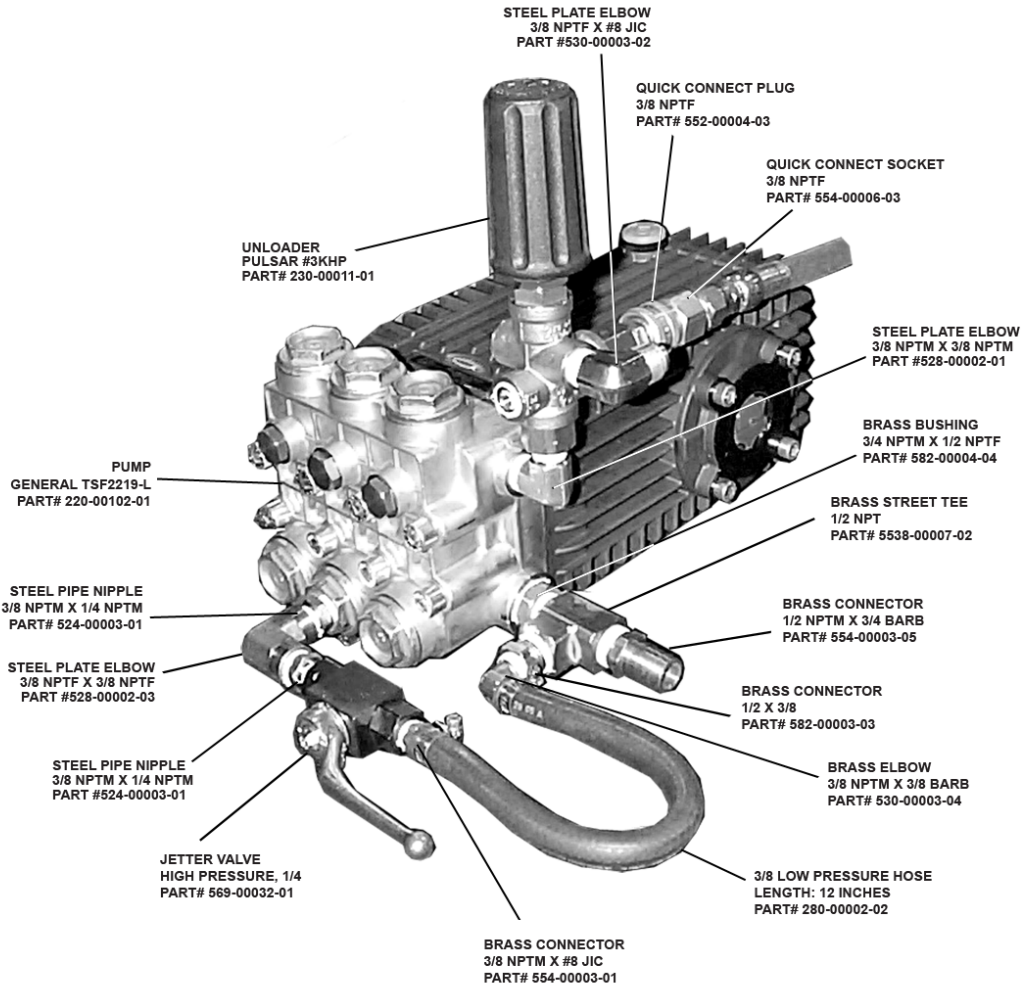

Hose, Wand & Gun

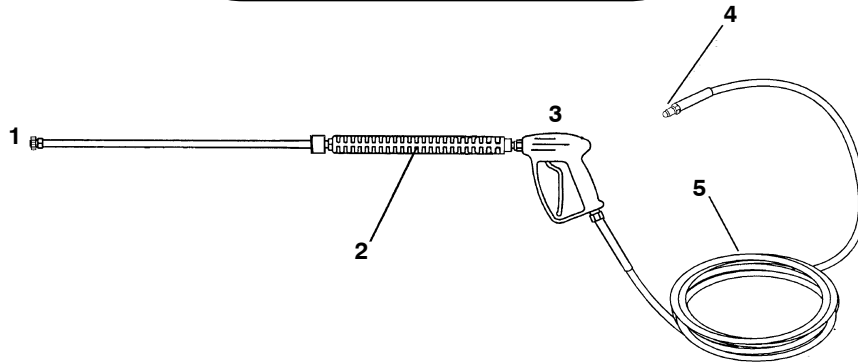

Ref.#	Part #	Description	Qty.
1a	270-00011-01	Nozzle, Water #5.5 0°	1
1b	270-00011-02	Nozzle, Water #5.5 15°	1
1c	270-00011-03	Nozzle, Water #5.5 25°	1
1d	270-00011-04	Nozzle, Water #5.5 40°	1
2	265-00001-01	36" Wand, Insulated	1
3	275-00001-01	ST1500 Trigger Gun	1
4	552-00003-03	3/8" Quick Connect, Male	1
5	284-00001-01	Hose 3/8" X 50" R-1 Swivel Ends	1

Belt Drive Pump

General Pump TSF2219-L Triplex Plunger Pump



Ref#	Part#	Description	Qty.
1	220-00102-01	TSF2219-L Triplex Plunger Pump Complete (BV500,600)	1
2	221-00001-02	Manifold, Brass Head	1

Pump Repair Kits (Not Shown)

Part #	Description	Qty.
221-00002-01	Check Valve Assembly Kit #1	6
221-00018-01	Oil Seal Kit #2	3
221-00026-01	Oil Ring and Valve Cap Kit #5	6
221-00010-01	Head Packing Complete Kit #28	1

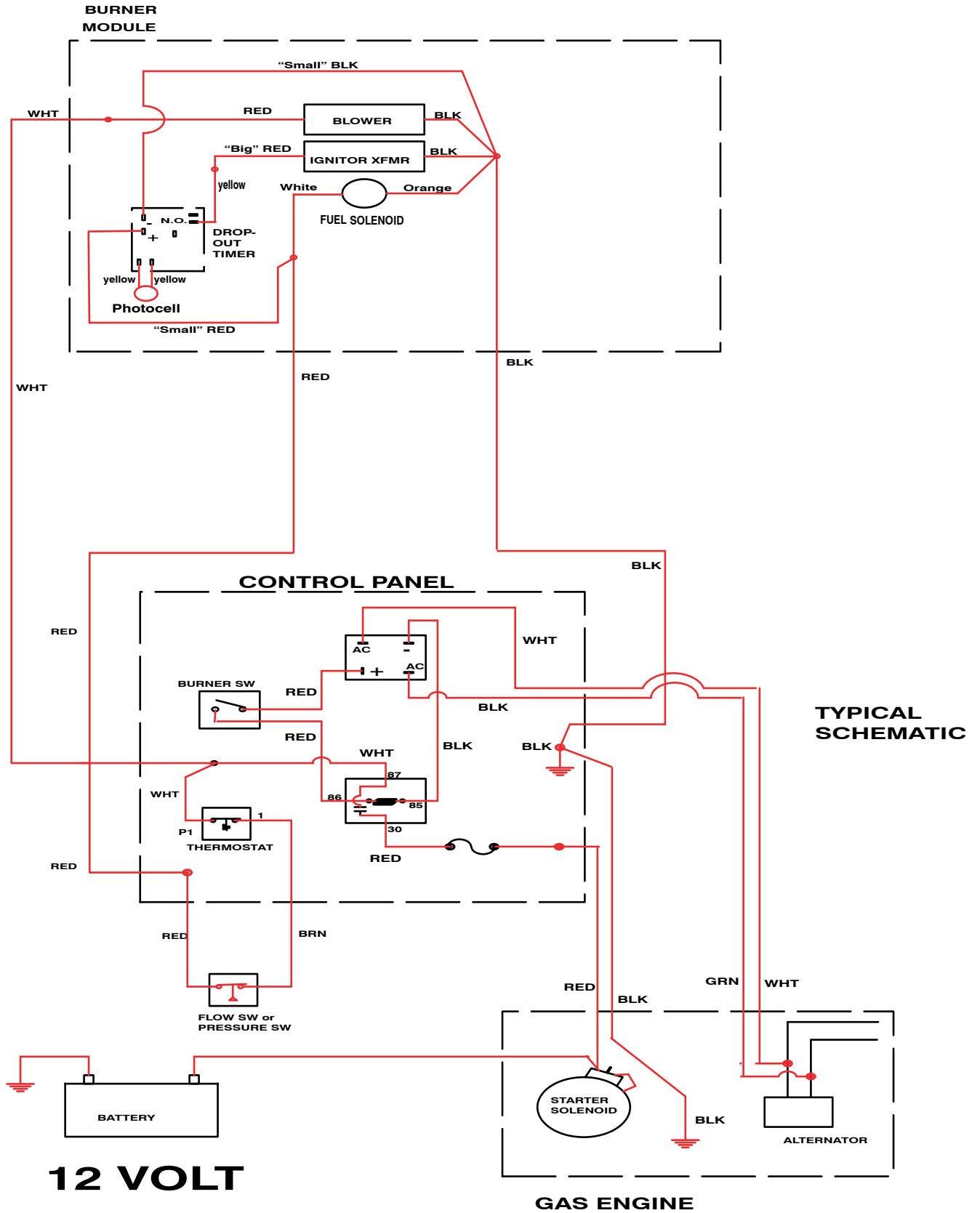

12 VOLT Electrical Schematic

Troubleshooting

problem	cause	action
Low Water Pressure	Insufficient water source Old or incorrect nozzle Plumbing or hose leak Obstruction in spray nozzle Chemical valve open Unloader valve worn Pump valves dirty or worn	Check hose size/water source Replace nozzle Tighten, repair or replace leak Clean or replace nozzle Close valve or submerge hose Replace unloader Clean or replace packing/valves
No Chemical Flow	Detergent valve closed Low detergent level Chemical screen dirty	Open detergent valve Fill detergent container Clean detergent screen
Pressure Relief Valve Leaks	Nozzle is dirty Defective relief valve Unloader adjusted incorrectly Restriction on discharge hose Scale restricting flow in coil	Clean or replace nozzle Replace relief valve Adjust unloader valve Remove nozzle and flush line Clean coil
Pump Motor Not Running	Pump motor switch off GFCI tripped No voltage to machine Clogged water nozzle Insufficient voltage/amperage	Turn on pump motor switch Reset and test GFCI Check power source Clean water nozzle Use proper drop cord
Pump Noisy	Air in suction line Pump valves dirty Check valve springs worn Low pump oil Pump bearings are worn Incoming water too hot	Check inlet water fittings Clean/replace pump valves Replace check valves Add SEA 30wt. non-detergent Replace/rebuild pump Reduce temperature/ambient
Water In Oil	High humidity environment Oil seal worn Plunger packing worn	Change oil frequently Check and replace oil seal Check and replace packing
Water Dripping/Pump	Plunger packing is worn Plunger retainer oil ring worn Cracked ceramics	Install new packing kit Replace oil ring Replace ceramics
Oil Dripping	Oil seal worn Cracked manifold	Check and replace oil seals Replace manifold
Fluctuating Pressure	Unloader not adjusted Valves worn Dirt or blockage in valve Pump sucking air Worn plunger packing	Adjust to specifications Replace with valve kit Clean or replace valve Check water/detergent supply Replace packing kit
Pump Head Overheating	Extended period in bypass	Pull trigger gun for water flow

WARRANTY

MANUFACTURER LIMITED WARRANTY

ENGINES

Honda GC Series Engines; ONE Year from date of purchase Honda will repair or replace any manufacturer defect at their expense. To be handled directly by Honda Service Centers. See owners manual for details.

Honda GX Series Engines; TWO years from date of purchase Honda will repair or replace any manufacturer defect at their expense. To be handled by Honda Service Centers. See owners Manual for details.

Vanguard Series Engines; TWO years from date of purchase Briggs and Stratton will repair or replace any manufacturer defect at their expense. To be handled by Briggs and Stratton Service Centers. See owners Manual for details.

Robin Series Engines; TWO years from date of purchase Robin/Subaru will repair or replace any manufacturer defect at their expense. To be handled by Robin/Subaru Service Centers. See owners Manual for details.

Yanmar Diesel Engines; TWO years from date of purchase Yanmar will repair or replace any manufacturer defect at their expense. To be handled by Yanmar Service Centers. See owners Manual for details.

ELECTRIC MOTORS

Marathon and Baldor brand electric motors have a manufacture limited warranty of one year from purchase date to repair or replace the motor, at their options, any manufacturing defects.

The limited warranty does not include damage from low voltage or amperage use, high voltage or amperage use, water, or any other operator incurred damage.

PUMPS

Pump manufacturers offer a "one and five" limited warranty on tri-plex ceramic plunger type pumps, from date of purchase.

The body, head and power train of the pump is warranted for 5 years from date of purchase against manufacturer defects. See owners manual for details. The valves, packings and "o"rings are warranted for one year from date of purchase against manufacturer defects. See owners manual for details. Pump manufacturers offer a one year limited warranty on Axial Type pumps from date of purchase. See owners manual for details.

NOTE - Over Heated Pumps void all warranties.

ACCESSORY PARTS

Including, but not limited to; unloader valve, thermal relief valve, reels, easy start valve, chemical injector, rotating nozzles, spray tips, spray guns, wand extensions, telescoping wands, ball valves, sand injectors, quick couplers, high pressure hose, ground fault interrupter; all burner electronics and wiring, flow switches, diesel fuel injectors are warranted for repair or replacement by Equipment Manufacturer for a period of 90 days from date of purchase. Including, but not limited to; Surface Cleaners, Becket or Wayne Burners, Burner Fans and Heater Coils warranted against manufacture defects for repair or replacement by Equipment Manufacturer for a period of one (1) year from date of purchase. Including, but not limited to; Cart or Frame warranted against manufacture defects for repair or replacement by Equipment Manufacturer for a period of one (1) year from date of purchase.

LIMITATION OF LIABILITY

Amazing Machinery and Equipment Manufacturer liability for special, incidental, or consequential damages is expressly disclaimed. In no event shall any liability exceed the purchase price of the product in question. The warranty contained herein is in lieu of all other warranties express or implied, including any implied warranty of fitness for particular purpose.

NOTE - It is understood that a manufacturers limited warranty pertains to equipment used in it's prescribed manner, without abuse, and does not include wear and tear.

NOTE - All freight charges incurred on warranty situations are the responsibility of the customer.

Specifications, Warranties and Pricing are subject to change without notice.

*Refund does not include shipping/handling fees. No refund will be given for installation kits. Customer is responsible for lost or misdirected packages. It is recommended that the customer insure the package for its full retail value. This warranty does not cover or include any damage as a result of acts of God, improper installation, alteration, negligence or abuse.