

Gasoline Water Pump Owner's Manual

PD50

PD80

PD100

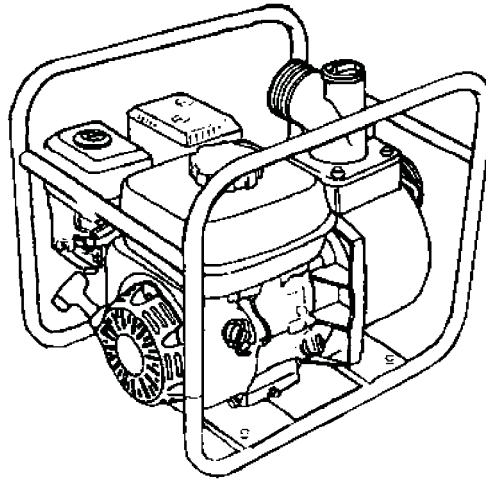

SAVE THIS MANUAL FOR FUTURE REFERENCE

This manual provides information regarding the operation and maintenance of these products. We have made every effort to ensure the accuracy of the information in this manual. We reserve the right to change this product at any time without prior notice.

Please keep this manual available to all users during the entire life of the gasoline water pump.

PLEASE NOTE!

The provided strainer must be installed properly onto the suction hose when the machine is in operation. Please read the user manual for complete instructions prior to use!

CONTENTS

I . General Safeguards	1
II . Location of Component Parts	3
III. Operation before Starting Up	4
IV. Starting of Engine	9
V . Use in Highland Areas	11
VI. Operation of Water Pump	12
VII. Shutting Down the Engine	13
VIII. Maintenance	14
IX. Transportation and Storage	19
X . Troubleshooting	21
XI. Specifications	23

I . General Safeguards

Safety Precautions



Please read this operation manual to have a thorough understanding of the content there before use the product. Failure to do so may lead to personal injury or mechanical damage.

Before starting the engine, perform inspections according to the procedures described on pre-operation inspections to avoid accidents and damage to your machine.

For safety, never attempt using this GEP (gasoline engine powered) water pump to deliver inflammable or corrosive liquids (such as gasoline and acids). Likewise, corrosive mediums, seawater, chemical solvents, alkaline liquids (such as used gasoline, liquor and honey) should be avoided.

Place the water pump on a solid, level position surface to avoid tilting or turnover that may give rise to spilling of fuel.

To prevent fire hazards, keep the pump well ventilated during operation and maintain a distance of at least 1 meter between the machine and the wall or other machines. Keep away from inflammable substances.

Do not allow children and pets to enter the working area as this may increase the chance of their getting burned by hot surfaces of the operating parts.

Know how to stop the water pump quickly how to operate the controls. Do not use the pump against the prescribed operating rules.

WARNING:

Safety Precautions

The gasoline fuel is highly inflammable and may explode under certain conditions.

Do the fueling with the engine shut down and in a well-ventilated environment. No smoking is allowed and no open fire or sparks allowed to exist in areas where fueling is carried out or the fuel is

stored.

Do not allow the fuel to overflow the fuel tank. Be sure to recap the tank and tighten it after refueling.

When fueling, take care not to spill the gasoline about as the gasoline vapor may easily get ignited to cause a fire hazard. Be sure to remove the spilled gasoline as by wiping before starting the engine.

Do not run the engine indoors or in a poorly ventilated space as the exhaust gas produced by the running engine contains toxic carbon monoxide that may cause the loss of personal consciousness or even death.

II . Location of Component Parts

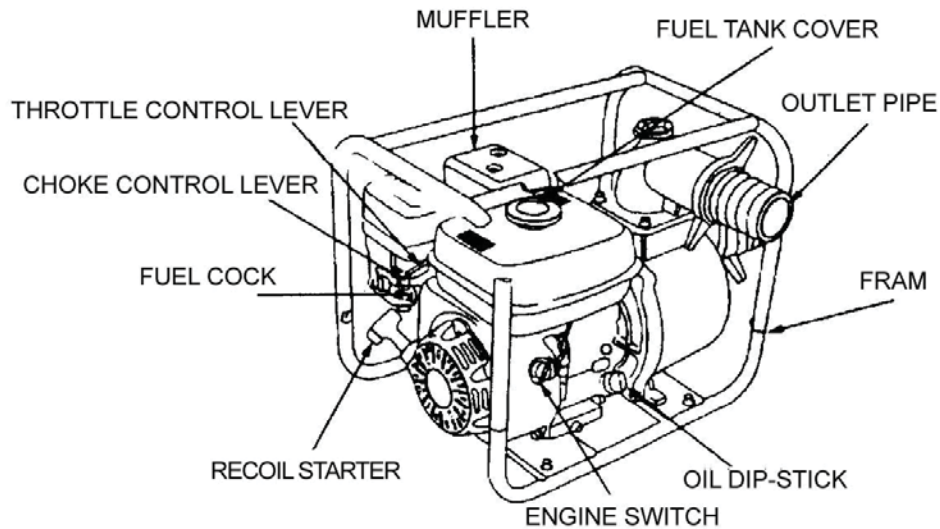

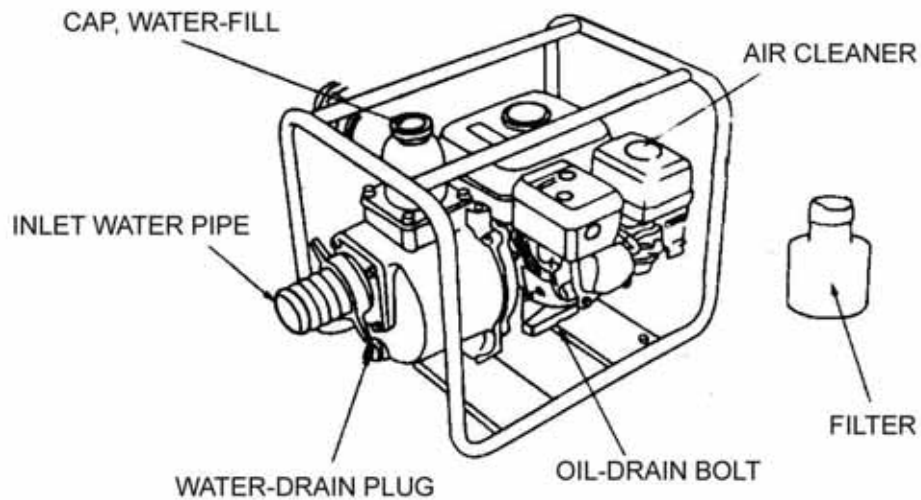

III. Operation before Starting Up

1. Connecting the water inlet

Connect the water inlet with a commercially available hose, connector and fastener clip. The inlet hose must be a continuous non-foldable structure with a length not more than required and should be placed near to the source of water so as to achieve the pump should be fitted to the end of the hose with the hose connector as shown in the figure below.

CAUTION: Before pumping water, attach the filter to the end of the hose to filter out foreign matters in the water, the presence of which may cause clogging and damage to the wane wheel.

NOTE: The hose connector and fastener clip should be securely fastened to prevent air leaks and reduction in suction power. A loose hose will reduce the pump performance and self-suction capacity.

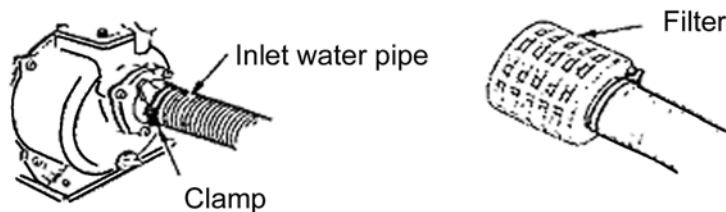

2. Connecting the water outlet

Connect the water outlet with a commercially available hose, hose connector and fastener clip. Large diameter hoses are the most effective while small ones will increase the flow resistance and reduce the output power of the pump.

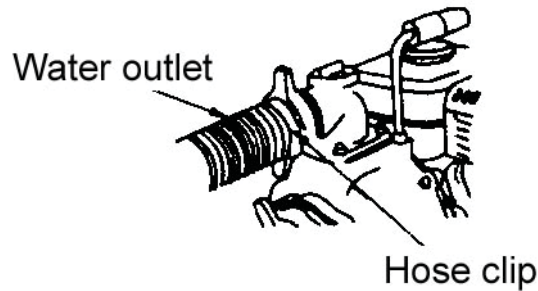

NOTE:

Be sure to the fastener clip is securely fastened to prevent the outlet hose from coming off under high water pressure.

3. Checking the oil level

CAUTION:

- The oil is one of the major factors affecting engine performance and life. Do not use dirty oil or vegetable oil.
- Be sure to check the oil level with the engine shut down and placed on a level surface.

Please use the SE15-40, 4-stroke engine oil as recommended.

Please use the type of oil with a proper viscosity according to the local average temperature.

Oil shortage alarm system (OSAS) (installation position)

The OSAS is designed to avoid damage of the engine due to the shortage of oil in the crankcase. The system will automatically shut down the engine just before the crankcase oil level drops down to the minimum line of safety (with the engine switch staying in the ON position).

If the engine is shut down and cannot be started again, check the oil level before initiating further troubleshooting procedures.

Remove the oil dipstick and wipe it dry.

Insert the dipstick into the oil filler but not screw it in.

Replenish the crankcase with the recommended type of oil until the oil level comes up to the upper most position of the refilled if the existing oil level is found too low.

CAUTION:

- Running the engine at a low oil level will cause damage to it.

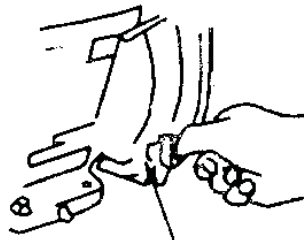

Oil dipstick

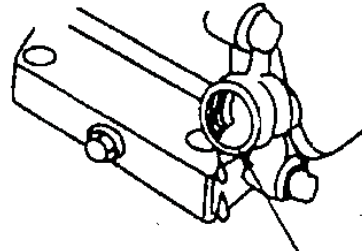

Upper oil level

4. Checking the fuel level

Uncap the fuel tank and check the fuel level. Pouring gasoline if the fuel level is found too low.

Please use the type of gasoline recommended by the Dealer (Using the low lead content or lead-free gasoline type is good for minimizing carbon deposits inside the combustion chamber).

Do not use a mixture of gasoline and oil or dirty gasoline to prevent dirt, dust or water from entering the fuel tank.

CAUTION:

- The gasoline fuel is highly inflammable and may explode under certain conditions.
- Do the fueling with the engine shut down and in a well-ventilated environment. No smoking is allowed and no open fire or sparks allowed to exist in areas where fueling is carried out or the fuel is stored.
- Do not allow the fuel to overflow the fuel tank. Be sure to recap the tank and tighten it after refueling.
- When fueling, take care not to spill the gasoline about as the gasoline vapor may easily get ignited to cause a fire hazard. Be sure to remove the spilled gasoline as by wiping before starting the

engine.

- Avoid frequent or extensive exposure of the skin to gasoline or breathing in the gasoline vapor. Keep the gasoline out of the reach of children.
- Fuel tank capacity: 1.0 gallons (US. 3.6 liters)

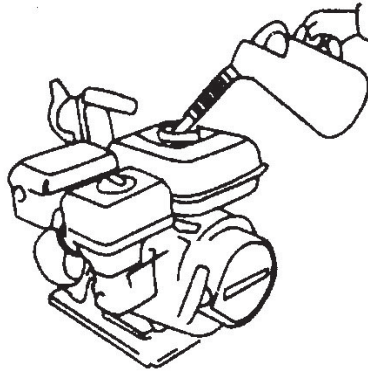

5. Checking the air cleaner filter element

Screw the wing nut and remove the washer and cleaner cover.

Check the filter element to see if it is too dirty and clean it if necessary.

CAUTION:

Do not run the engine without the air cleaner as this may quicken engine wear if dirt or dust is sucked into the engine through the carburetor.

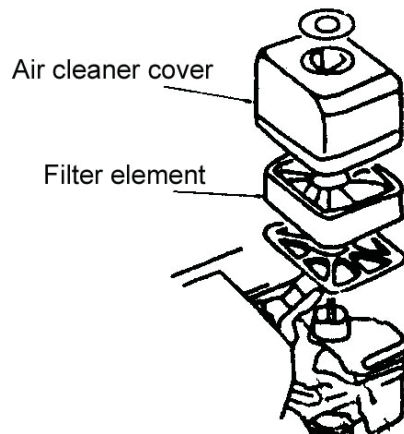

6. Checking and filling the pump with cooling water

The pump must be filled with water before it is put to operation.

CAUTION:

• Do not attempt running the pump without cooling water or the pump will get overheated. Extensive running without cooling water may also damage the air tightness of the pump. If the pump is found running dry, stop the engine and pouring in water when it cools down.

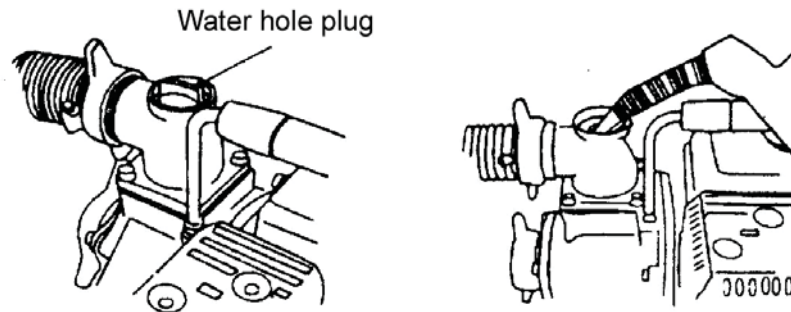

IV. Starting engine

1. Turn on the fuel tap (by setting it to the ON position).
2. Close the choke.

NOTE:

• The choke is not required when starting the engine warm or the ambient temperature is rather high, (i.e. keep the choke open when starting the engine).

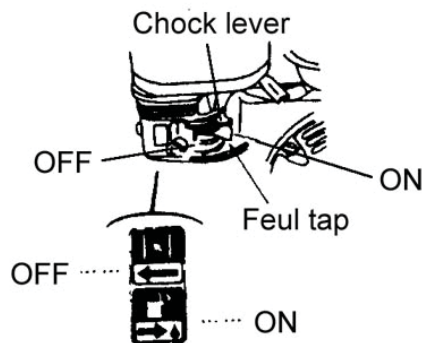

3. Set the engine switch to the ON position.

Engine switch

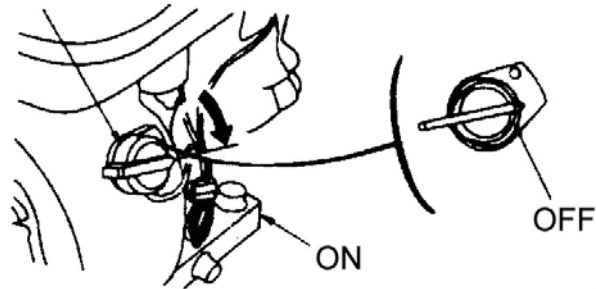

4. Turn the throttle control lever slowly to the left.

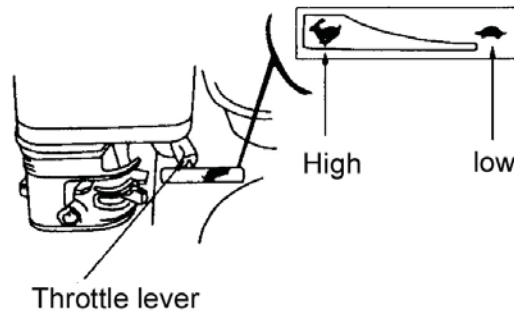

5. Gently pull up the starter lever until a resistance is felt and then quickly pull it up.

CAUTION:

•Do not allow the starter lever to retract quickly into the engine. Let it go back gently to avoid damaging the starter.

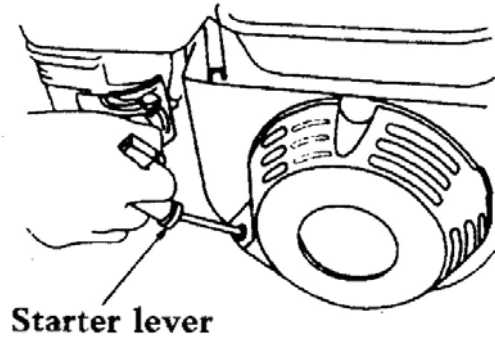

V. Use in Highland Areas

Operation in Highland Conditions

In highland areas (with a high ASL elevation), the air-fuel mixture produced by a standard carburetor will be too thick and result in a reduced engine performance and soared fuel consumption. For operation in highland areas, the engine performance may be increased by using a smaller diameter carburetor nozzle and readjusting the carburetor idle speed. If the water pump is frequently used in areas with a ASL elevation of more than 1800 meters (6000 feet), ask the local dealer to replace or readjust the carburetor beforehand. Even if the engine is fitted with a carburetor nozzle of an appropriate size, the engine power will still go down by about 3.5% each time when the ASL elevation goes up by 305 meters (1000 feet). If no replacement or readjustment is ever made of the carburetor, the highland effect of the engine output power will be even more obvious.

CAUTION:

- Using the water pump in areas where the ASL elevation is lower than suitable for the carburetor nozzle will lead to a decreased engine performance and overheating of the engine and even cause serious damage to the engine due to an extremely thin air-fuel mixture.

VI. Operation of the Water Pump

1. Gradually open the choke after the engine warms up.

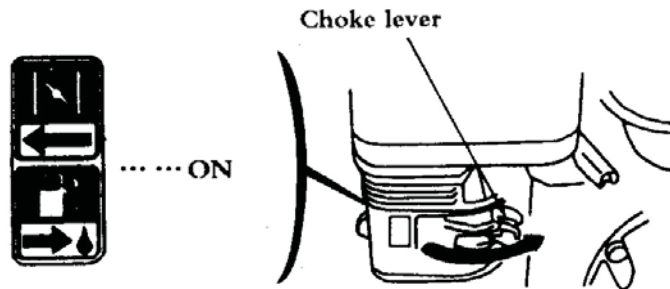

2. Set the throttle to the predetermined RPM.

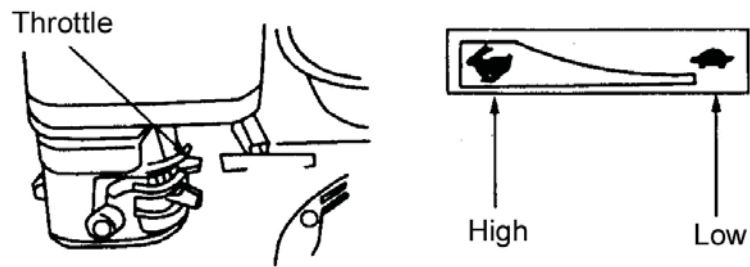

VII. Shutting Down the Engine

1. Set the throttle control lever to the right end.
2. Set the engine switch to the OFF position.

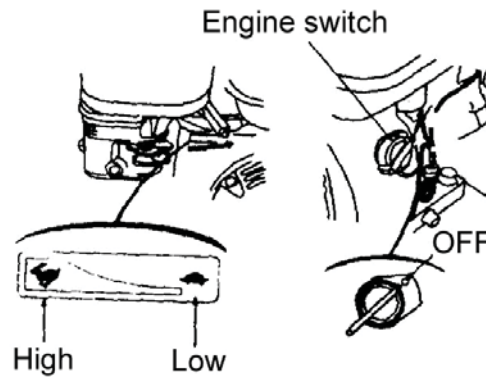

3. Turn off the fuel tap (by setting to the OFF position).

NOTE:

- To shut down the engine in an emergency, simply set the engine switch to the OFF position.

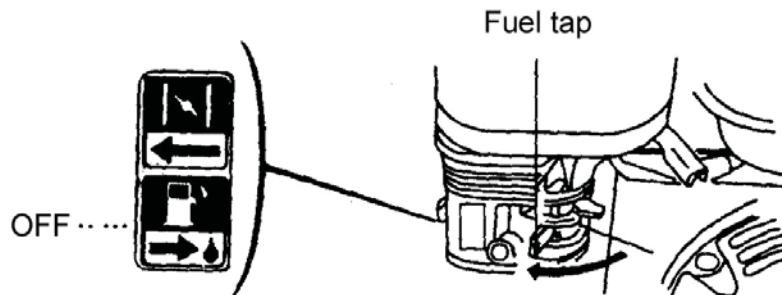

VIII. Maintenance

Periodic inspections and fine-tuning are simply indispensable to keep the water pump working with high performance and regular maintenance may also lengthen the pump life. Supplied in the table on the next page are intervals at which the schedules maintenance jobs are to be done.

WARNING:

- Before any maintenance attempt, be sure to shut down the engine. If the maintenance job has to be done with the engine at work, it should take place in a well-ventilated space as the exhaust gas contains toxic carbon monoxide that causes the loss of personal consciousness or even death.

CAUTION:

- In cases when the pump is used to suck up seawater, be sure to flush it with fresh water immediately after use to minimize corrosion and remove deposits.
- Always use the original parts and relevant tools supplied with the machine to carry out maintenance. Failure to do this may cause damage to the pump.

NOTE:

- (1) Inspection and maintenance should take place more frequently if the pump is used in a dirty environment.
- (2) Leave the following inspection and maintenance jobs to the authorized dealers unless you, the user, have the relevant tools and necessary DIY skills. In the latter case, refer to service manual.

Table of Maintenance Schedules

Item	Normal maintenance period	Each time	Per month or 12 hours	Per month or 50 hours	Per month or 100 hours	Per month or 300 hours
Check engine oil level		○				
Replace engine oil level			○		○	
Air cleaner check		○				
Air cleaner for clean						
Spark plug				○		○*
Fuel supply	Replace per every two years					
Wane wheel						○*
Pump case cover						○*
Water inlet						○*

Note: “*” items will be maintained with the help of dealers from general power machinery Co., Ltd.

1. Replacing the engine oil

Oil drains easily and quickly while the engine is warm.

1. Remove the oil dipstick and drain bolt to let out the oil.
2. Screw the drain bolt back in place and tighten it.
3. Pour in clean oil until the desired level is reached.

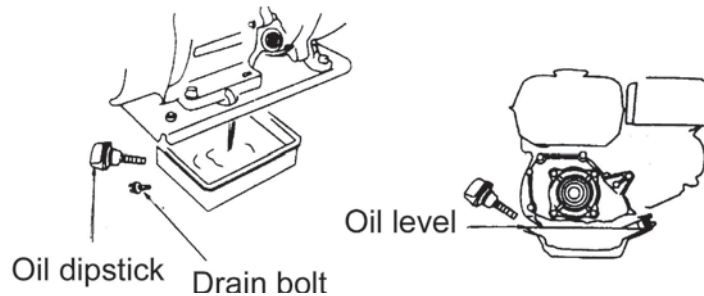

Oil sump capacity: 0.6 liters

Clean the hands with soap if stained with the engine oil.

NOTE: Be sure to keep the environment clean when disposing used engine oil. We suggest you collect the waste oil in a container to be sent to a waste disposal site or a recycling service center or spill it in the garbage or on the ground.

2. Maintaining the air cleaner

A dirty air cleaner will let less air into the carburetor. To prevent carburetor malfunctions, be sure to maintain the air cleaner periodically. More frequent maintenance of the air cleaner will be necessary if the pump is working in an extremely dirty environment.

DO not clean the air cleaner with a low ignition point solvent because it may get enflamed or even explode under certain circumstances.

CAUTION: Do not use the water pump without an air cleaner. The dirt or dust if sucked into the engine may quicken engine wear.

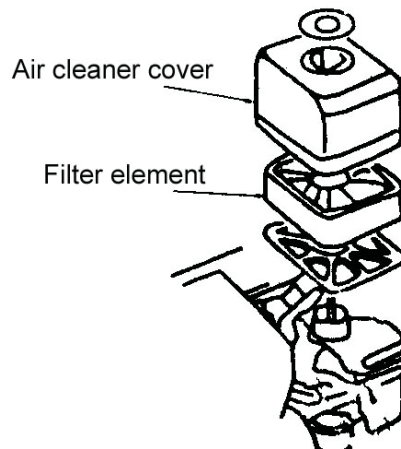

1) Unscrew the wing nut and remove the air cleaner cover and filter element.

2) Clean the filter element with a detergent solution inflammable or with a high ignition point and let it dry thoroughly after cleaning.

3) Immerse the filter element into clean oil and then squeeze out the excessive amount of oil.

4) Put the filter element as well as the air cleaner back in place.

3. Maintaining the spark plug

The recommended type of spark plug is NHSP LD P6RTC.

To ensure normal operation of the engine, the spark plug should have a correct gap and should remain free of carbon deposits.

1) Remove the plug cap.

The muffler may be very hot if the engine is still running. Take care not to touch the muffler.

2) Check the spark plug visually. Discard the spark plug if it is obviously worn out or the insulation ring on it is broken or cracked. Clean the spark plug with a brush when put it back in place.

3) Check the plug gap with a feeler gauge.

Vary the gap by moving the side electrode.

Normal plug gap: 0.70~0.80mm

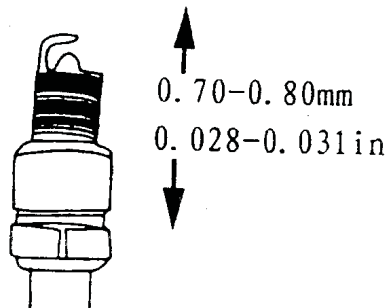

4) Check the plug O-ring for normal condition. Screw it in with the plug wrench to protect the plug thread.

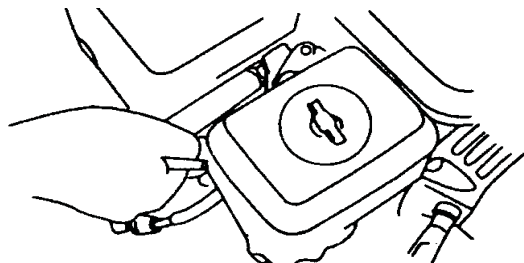

NOTE:

- In the case of screwing in a new spark plug, tighten it by an additional 1/2 screw turn after the plug reaches and pushes on the O-ring, while in the case of a used spark plug, an additional 1/2~1/4

screw turn is necessary.

CAUTION:

- Make sure the spark plug is properly tightened. Improper tightening may cause the engine to be overheated or damaged. Never use spark plugs with an incorrect thermal value range.

IX. Transportation and Storage

CAUTION:

- To avoid causing a fire hazard, let the engine cool down before transportation or indoor storage of the pump.

- Before transporting the pump, set the fuel tap to the OFF position and place the pump body in a level position to prevent the fuel from spilling out. The spilled gasoline or the gasoline vapor may get ignited.

Note and do the following before storing pump for an extended period of time:

- 1) Make sure the storage area is free of moisture or dust.
- 2) Clean the inside of the pump.

The pump may get clogged if it is used to suck up water containing such matters as earth, sand or heavy fragments.

Before storing, clean the pump by sucking up clean water or otherwise the vane wheel may be damaged when the pump is put to use again. After cleaning, unscrew the water drain plug to drain off the water from inside the pump casing as much as possible. Then screw the drain plug back into place.

- 3) Drain off the fuel.

- a. Turn off the fuel tap (OFF position), unscrew the drain screw from the carburetor float chamber to drain off the fuel from inside the carburetor and collect the gasoline in a suitable container.

- b. Turn on the fuel tap (ON position) and collect the gasoline in a suitable container.

- c. Screw the carburetor fuel drain screw back into place.

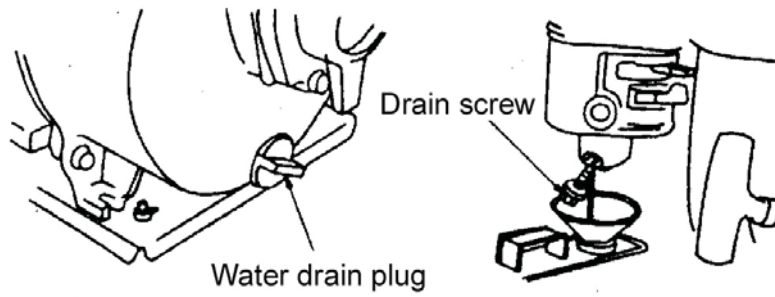

4) Replace the engine oil.

5) Screw off the spark plug, pour a spoonful of clean oil into the cylinder, turn the engine alternatively for several times to allow uniform distribution of oil, and then screw in the spark plug again.

6) Pull up the starter lever until a resistance is felt. Stop pull for a while and pull it up again until the triangle mark on the starter wheel gets into collimation with the screw hole in the starter (as shown the sketch below). In this position, both the inlet valve and outlet valve is closed to prevent corrosion inside the engine.

7) Cover up the pump to keep out dust.

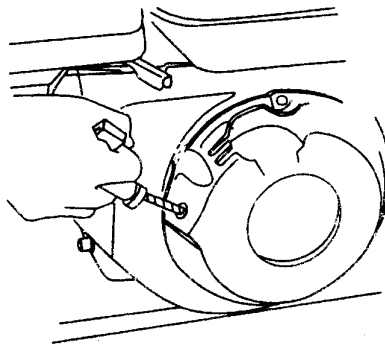

X. Troubleshooting

Engine unable to get started:

- 1) Is there enough fuel?
- 2) Is the fuel tap turned on?

3) Has the fuel reached the carburetor? Make the check by unscrewing the oil drain screw from under the carburetor with the fuel tap turned on.

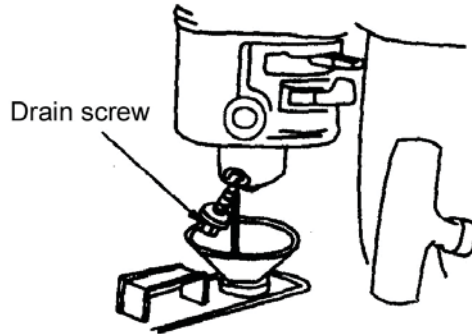

WARNING:

- Should there be a spill of fuel, be sure to clean it before checking the spark plug and start the engine or otherwise the spilled fuel or fuel vapor may get ignited

4) Is the engine switch set to the ON position?

5) Is there enough oil in the crankcase?

6) Is the spark plug generating sparks?

a. Uncap the spark plug, clear off the dirt from around the plug and remove the spark plug.

b. Fit the spark plug into the plug cap.

c. Turn on the engine with the side electrode and pull up the starter lever to see if there is sparks generated.

d. Ground the engine with the side electrode and pull up the starter lever to see if there is sparks generated.

e. Replace the spark plug if no spark is found.

Start the engine as directed in the operation manual if sparks are generated.

7) If the engine still refuses to get started, send the pump to any of the authorized dealers.

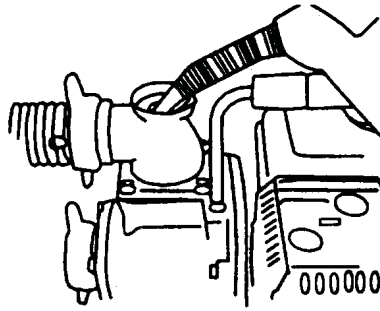

The pump unable to such up water:

- 1) Is it filled with enough amount of water?
- 2) Is the filter clogged?
- 3) Is the hose fastener clip tightened?
- 4) Is the hose damaged?
- 5) Is the suction head too high?
- 6) If the pump still fails to work, send it to any of the authorized dealers.

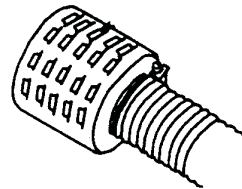
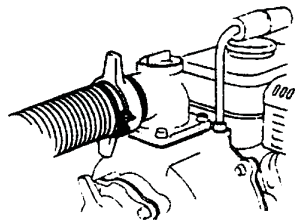

XI. Specifications

Type	PD50	PD80	PD100
Engine type	6.5HP	6.5HP	9.0HP
Max. Power	4.7kw(6.5HP)	4.7kw(6.5HP)	6.5kw(9.0HP)
Displacement	196cc	196cc	270cc
Fuel tank capacity	1.0 Gallons	1.0 Gallons	1.7 Gallons
Oil capacity	0.63 US. Qt. (0.6L, 20fl oz.)	0.63 US. Qt. (0.6L, 20fl oz.)	1.16 US. Qt. (1.1L, 37fl oz.)
Water intake pipe dia.	2"	3"	4"

Water output pipe dia.	2"	3"	4"
Revolution	3600rpm	3600rpm	3600rpm
Max. overhead lift	92ft	98ft	98ft
Max. suction lift	26ft	26ft	26ft
Max. flow rate	158 GPM	220 GPM	427 GPM
Noise Level	76dB@7m (22 feet)	76dB@7m (22 feet)	79dB@7m (22 feet)
Size	18.7×15.6×15.4(in.)	21.3×17.5×19.3(in.)	25.2×20.7×22.3(in.)

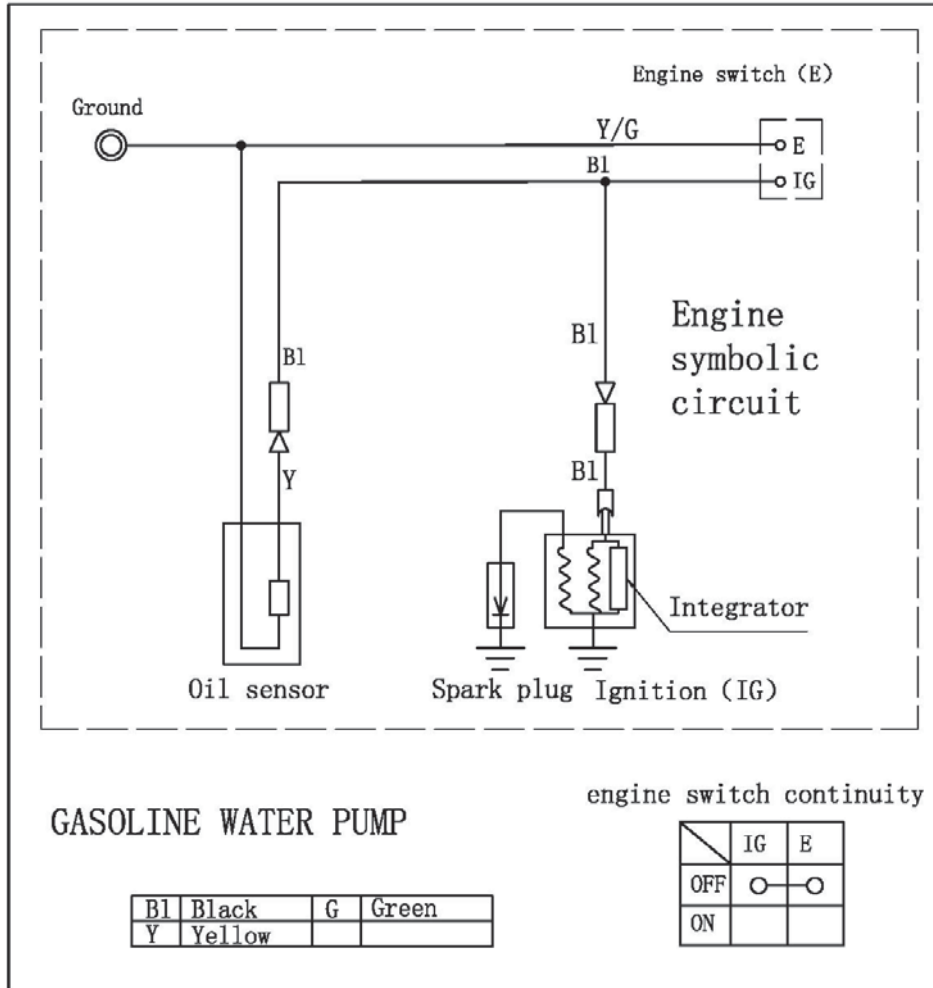

PARTS LIST AND ASSEMBLY (PD50/PD80)

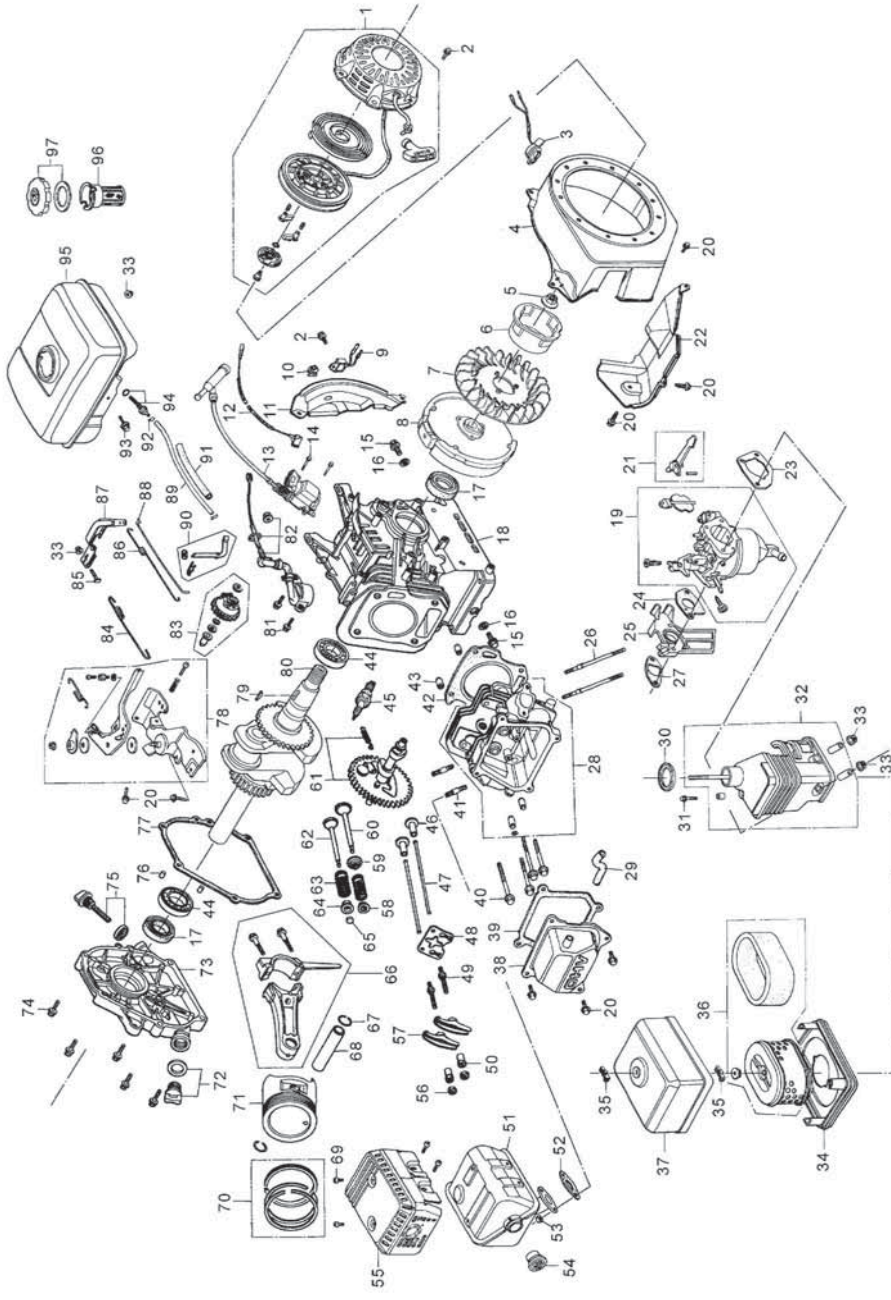

Item	Part	Qty	Description	Item	Part	Qty	Description
1	21100	1	Starter comp, recoil	22	19003	1	Shroud comp
2	GB5787-86	4	Flange bolt M6x8	23	90002	1	Packing air cleaner
3	12302	1	Engine switch	24	90003	1	Packing, carburetor
4	12310	1	Fan, cover comp	25	90004	1	Insulator, carburetor
5	GB6177-86	1	Flange nut M14	26	91004	2	Bolt head, 6x112
6	19005	1	Pulley, starter	27	90005	1	Packing, insulator
7	19001	1	Fan, cooling	28	11250	1	Head comp, cylinder
8	81200	1	Flywheel comp	29	92001	1	Casket, muffler
9	87500	1	Amplifier	30	16005	1	Seal, air cleaner
10	12302	1	Clip. Wire darkness	31	GB5789-86	1	Flange bolt M6x20
11	19002	1	Plate, side	32	16003	1	Case comp, air cleaner
12	19003	1	Switch wire	33	GB6177-86	5	Flange nut M6
13	81100	1	Coil assy. ignition	34	16002	1	Separator, air cleaner
14	GB5789-86	2	Flange bolt M6x25	35	16007	2	Nut, M6
15	13203	2	Bolt, drain lug	36	16001	1	Element, air cleaner
16	12217	2	Washer, drain lug	37	16004	1	Cover comp, air cleaner
17	900008	2	Oil seal, 25x41x6	38	11240	1	Cover comp, head
18	12200	1	Crank case assy.	39	90006	1	Exhaust piper
19	17300	1	Carburetor assy.	40	GB5789-86	4	Flange bolt M8x60
20	GB5787-86	13	Flange bolt M6x12	41	91005	2	Bolt head, M8x32
21	17316	1	Lever comp, choke	42	90007	1	Casket, cylinder head

43	92002	2	Pin, dowel, 10x16	65	11213	1	Rotator, valve
44	GB/T276-94	2	Radial ball bearing (6025	66	13106	1	Connecting rod assy.
45	11202	1	Plug, spark	67	13015	2	Clip, piston pin
46	15002	2	Lifter, valve	68	13104	1	Pin, piston
47	15001	2	Rod, push	69	GB847-85	5	Screw, tapping M5x8
48	11215	1	Plate, push rod guide	70	13100	1	Ping set, piston
49	11214	2	Bolt, pivot	71	13101	1	Piston
53	GB/T 6170	2	Nut, M8	72	12103	1	Cap, oil hole
54	18003	1	Arrester, spark	73	12100	1	Crankcase cover
55	18002	1	Protector, muffler	74	GB5789-86	6	Flange bolt M8x32
50	11204	2	Nut, Arm, valve rocker	75	12102	1	Cap assy. oil filler
51	18001	1	Muffler	76	92003	2	Pin, dowel, 8x14
52	18101	1	Casket EX. Pipe	77	90001	1	Packing, case cover
56	11206	2	Nut, pivot adjusting	78	17200	1	Control assy.
57	11205	2	Arm, valve rocker	79	GB/T 99-88	1	Key, 25x18
58	11211	1	Retainer, IN. Valve spring	80	13000	1	Crankshaft comp
59	11216	1	Seat, valve spring	81	GB5789-86	2	Flange bolt M6x12
60	11208	1	Valve, IN.	82	87400	1	Switch assy. oil level
61	15100	1	Camshaft assy.	83	12230	1	Governor assy.
62	11209	1	Valve, EX.	84	17001	1	Spring, governor
63	11206	2	Spring, valve	85	91003	1	Bolt, governor arm
64	11212	1	Retainer, EX. Valve spring	86	17002	1	Spring, throttle return

87	17004	1	Arm, governor	93	GB5789-86	1	Flange bolt M6x30
88	17003	1	Rod, governor	94	17101	1	Joint, fuel tank
89	91009	1	Tube, fuel	95	17120	1	Tank fuel
90	12208	1	Shaft, governor assy.	96	17130	1	Filter, fuel
91	17102	1	Rubber, supporter	97	17110	1	Fuel filler cap
92	91002	2	Clip, tube				

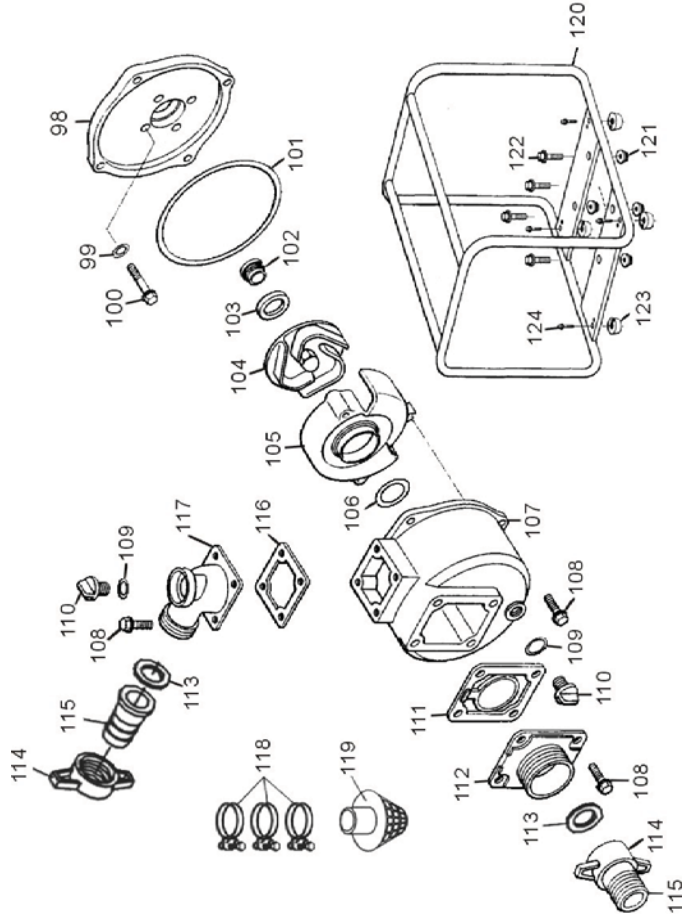

Item	Part	Qty	Description	Item	Part	Qty	Description
98	TS1300	1	Assembly, pump cover	112	TS1002	1	Suction port
99	TS1301	4	Washer	113	TS2001	2	Coupling Packing
100	GB5787-86	4	Flange Bolt M8x53	114	TS2002	2	Hose Joint
101	TS1006	1	O-Ring, water pump	115	TS2003	2	Hose Coupling
102	TS1303	1	Mechanical seal A	116	TS1005	1	Discharge gasket
103	TS1101	1	Mechanical seal B	117	TS1004	1	Discharge port
104	TS1100	1	Impeller, water pump	118	TS2020	3	Hose Band
105	TS1008	1	Volute casing	119	TS2030	1	Strainer
106	TS1103	1	Ring, Volute casing	120	TS4100	1	Frame
107	TS1001	1	Pump case housing	121	GB6177-86	4	Flange nut M8
108	GB5787-86	12	Flange Bolt M8x25 (PD50) Flange Bolt M10x25 (PD80)	122	GB5789-86	4	Flange bolt M8x35
109	TS1013	2	O-ring, Plug	123	TS2111	4	Rubber pad, damping
110	TS1012	2	Plug	124	GB5787-86	4	Flange Bolt M6x16
111	TS1003	1	Flapper valve gasket				

PARTS LIST AND ASSEMBLY (PD100)

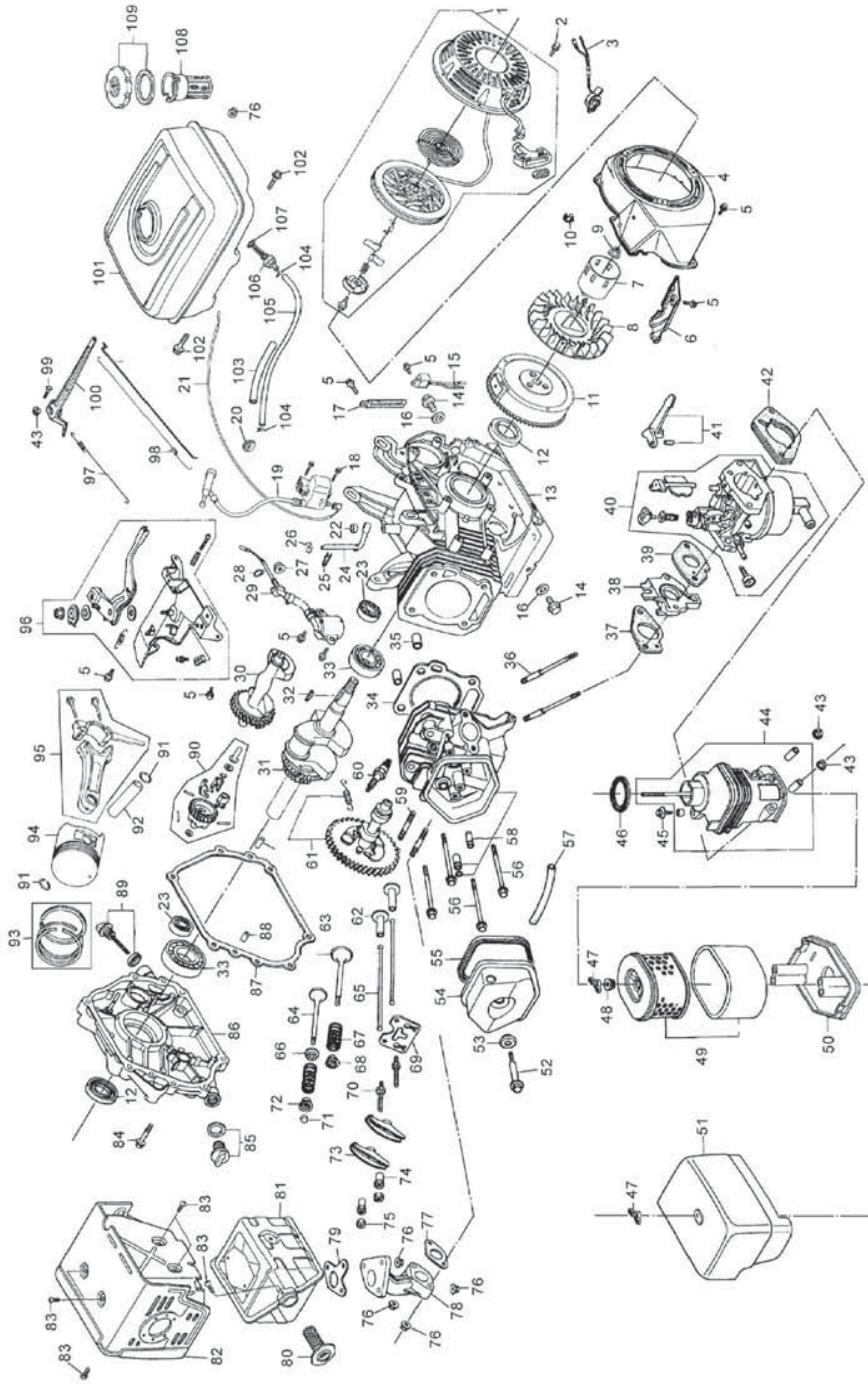

Item	Part	Qty	Description	Item	Part	Qty	Description
1	21100	1	Starter comp, recoil	21	81102	1	Cord stop switch
2	GB5787-86	3	Flange bolt M6x8	22	12216		Oil seal, 8x14x5
3	11082	1	Engine switch	23	GB/T276-94	2	Radial ball bearing (6202)
4	12310	1	Fan, cover comp	24	12208	1	Shaft, governor arm
5	GB5787-86	12	Flange bolt M6x12	25	12212	1	Pin, lock, 10mm
6	19003	1	Shroud comp	26	12209	1	Washer, 8.2x17x0.8
7	19005	1	Pulley, starter	27	GB6177-86	1	Flange nut M10
8	19001	1	Fan, cooling	28	12221	1	O-ring, 14mm
9	GB6177-86	1	Flange nut M16	29	12200	1	Switch assy. oil level
10	23007	1	Clip. Wire harness	30	13200	1	Weight, balancer
11	81200	1	Flywheel comp	31	13000	1	Crankshaft comp
12	12215	2	Oil seal, 35x52x8	32	GB/T 99-88	1	Key
13	12200	1	Crank case assy.	33	GB/T276-94	2	Radial ball bearing (6207)
14	12203	2	Bolt, drain lug	34	11219	1	Casket, cylinder head
15	87500	1	Amplifier	35	12220	2	Pin, dowel, 12x20
16	12217	2	Washer, drain lug	36	11218	2	Bolt head, 8x111
17	87601	1	Clip, wire	37	23003	1	Packing, insulator
18	GB5789-86	2	Flange bolt M6x25	38	23001	1	Insulator, carburetor
19	81100	1	Coil assy. ignition	39	23002	1	Packing, carburetor
20	81103	1	Grommet cord	40	23000	1	Carburetor assy.

41	22000	1	Stay manual choke	63	11208	1	Valve, IN.
42	23008	2	Packing, air cleaner	64	11209	1	Valve, EX.
43	GB6177-86	5	Flange nut M6	65	15001	2	Rod, push
44	12005	1	Case comp, air cleaner	66	11216	1	Seat, valve spring
45	GB5789-86	1	Flange bolt M6x20	67	11206	2	Spring, valve
46	12010	1	Seal, air cleaner	68	11211	1	Retainer, IN. Valve spring
47	16007	2	Nut, M6	69	11215	1	Plate, push rod guide
48	16008	2	Washer, drain lug	70	11214	2	Bolt, pivot
49	12010	1	Element assy. air cleaner	71	11213	1	Rotator, valve
50	12004	1	Separator, air cleaner	72	11212	1	Retainer, EX. Valve spring
51	12007	1	Cover comp, air cleaner	73	11205	2	Arm, valve rocker
52	11242	1	Bolt, head cover	74	11204	2	Nut, Arm, valve rocker
53	11243	1	Washer comp head cover	75	11206	2	Nut, pivot adjusting
54	11240	1	Cover comp, head	76	GB6177-86	6	Flange nut M8
55	11241	1	Exhaust piper	77	13202	1	Casket (B) EX. Pipe
56	GB5789-86	4	Flange bolt M10x80	78	13200	1	Pipe comp EX.
57	12001	1	Tube, breather	79	13010	1	Muffler stay
58	11250	1	Head comp, cylinder	80	13003	1	Arrester, spark
59	11217	2	Bolt head, M8x34	81	13020	1	Muffler
60	11202	1	Plug, spark	82	13030	1	Muffler guard
61	15100	1	Camshaft assy.	83	GB847-85	5	Screw, tapping M5x8
62	15002	2	Lifter, valve	84	GB5789-86	7	Flange bolt M8x35

85	12103	1	Cap, oil hole	98	17002	1	Spring, throttle return
86	12100	1	Crankcase cover	99	17005	1	Bolt, governor arm
87	12214	1	Packing, case cover	100	17004	1	Arm, governor
88	12213	2	Pin, dowel, 8x12	101	14200	1	Fuel tank
89	121102	1	Cap assy. oil filler	102	GB5789-86	2	Flange bolt M8x25
90	12230	1	Governor kit	103	14102	1	Rubber, supporter
91	13105	2	Clip, piston pin	104	14100	1	Fuel cock
92	13104	1	Pin, piston	105	14004	1	Outlet pipe ϕ 4.5x235
93	13100	1	Ping set assy. piston	106	17101	1	Joint, fuel tank
94	13101	1	Piston	107	17102	1	Rubber joint, fuel tank
95	13106	1	Connecting rod assy.	108	14302	1	Fuel filter
96	17220	1	Control assy.	109	14300	1	Fuel filler cap comp
97	17001	1	Spring, governor				

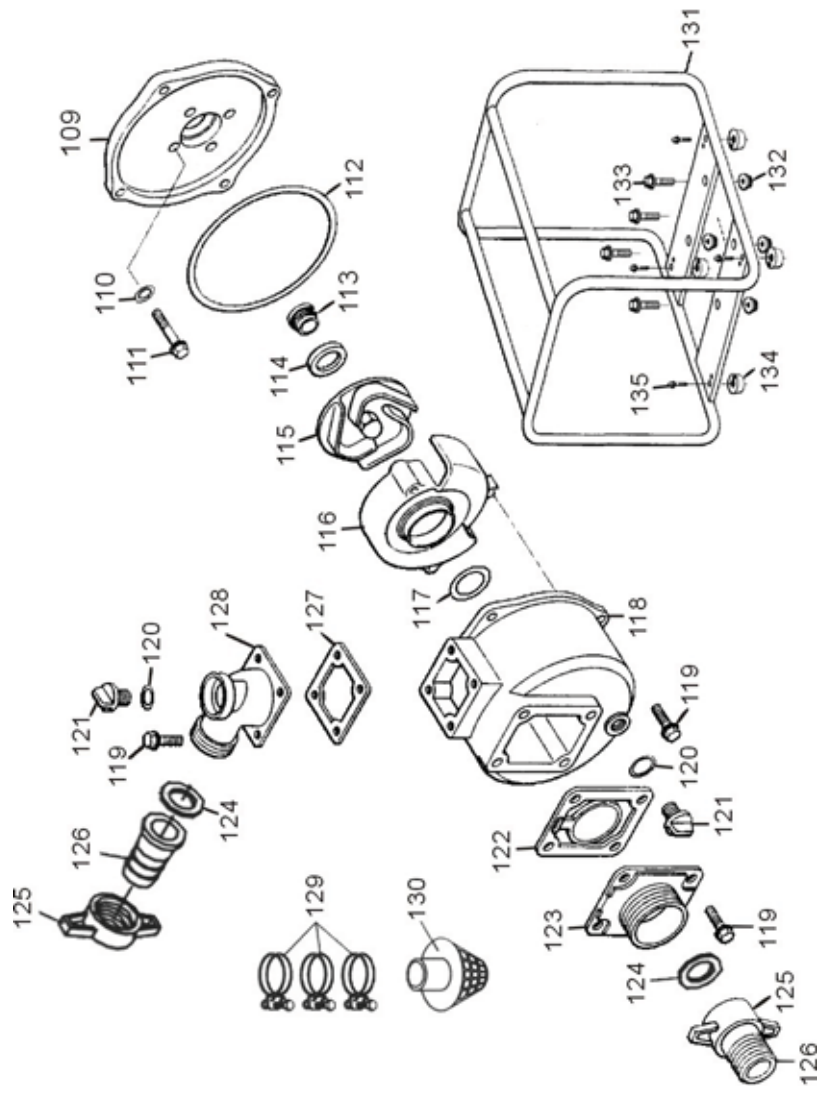

Item	Part	Qty	Description	Item	Part	Qty	Description
109	TS1300	1	Assembly, pump cover	123	TS1002	1	Suction port
110	TS1301	4	Washer	124	TS2001	2	Coupling Packing
111	GB5787-86	4	Flange Bolt M8x45	125	TS2002	2	Hose Joint
112	TS1006	1	O-Ring, water pump	126	TS2003	2	Hose Coupling
113	TS1303	1	Mechanical seal A	127	TS1005	1	Discharge gasket
114	TS1101	1	Mechanical seal B	128	TS1004	1	Discharge port
115	TS1100	1	Impeller, water pump	129	TS2020	3	Hose Band
116	TS1008	1	Volute casing	130	TS2030	1	Strainer
117	TS1103	1	Ring, Volute casing	131	TS4100	1	Frame
118	TS1001	1	Pump case housing	132	GB6177-86	4	Flange nut M10
119	GB5787-86	12	Flange Bolt M10x25	133	GB5789-86	4	Flange bolt M10x35
120	TS1013	2	O-ring, Plug	134	TS2111	4	Rubber pad, damping
121	TS1012	2	Plug	135	GB5787-86	4	Flange Bolt M6x16
122	TS1003	1	Flapper valve gasket				