

# **PDR80**

## **Tamping Rammer**

### **Owner's Manual**

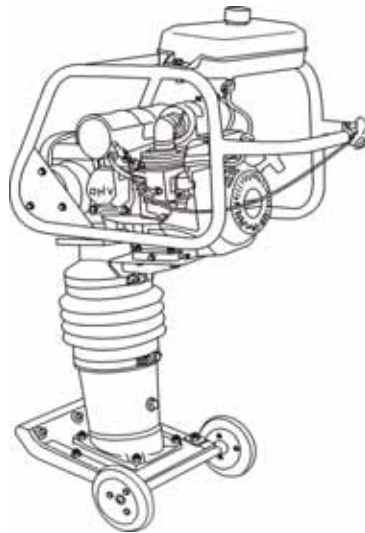

**SAVE THIS MANUAL FOR FUTURE REFERENCE**

This manual provides information regarding the operation and maintenance of these products. We have made every effort to ensure the accuracy of the information in this manual. We reserve the right to change this product at any time without prior notice.

Please keep this manual available to all users during the entire life of the Vibratory Rammer.

# TABLE OF CONTENTS

1. FOREWORD .....	1
2. EMISSION CONTROL SYSTEM INFORMATION .....	1
3. SAFETY INFORMATION .....	6
3.1 Operating Safety .....	6
3.2 Operator Safety while using Internal Combustion Engines .. .....	8
3.3 Service Safety .....	8
3.4 Label Locations .....	10
3.5 Safety Labels .....	11
3.6 Operating Labels .....	12
4. TECHNICAL DATA .....	14
4.1 Rammer .....	14
4.2 Sound Measurements .....	15
4.3 Vibration Measurements .....	15
5. OPERATION .....	16
5.1 Application .....	16
5.2 Recommended Fuel .....	16
5.3 Before Starting .....	16
5.4 To Start .....	16
5.5 To Stop .....	17
5.6 Low Oil Shutoff Switch (if equipped) .....	17
5.7 Proper Operation .....	18
5.8 Proper Compaction .....	18
6. MAINTENANCE .....	19

6.1 Periodic Maintenance Schedule .....	19
6.2 Servicing Air Cleaner .....	20
6.3 Engine Oil .....	21
6.4 Lubrication .....	22
6.5 Shoe Hardware .....	23
6.6 Long-Term Storage .....	23
6.7 Troubleshooting .....	24

## CALIFORNIA

### Proposition 65 Warning:



Engine exhaust, some of its constituents, and certain vehicle components, contain or emit chemicals known to the State of California to cause cancer and birth defects or other reproductive harm.

## 1. FOREWORD

This manual provides information and procedures to safely operate and maintain this model. For your own safety and protection from injury, carefully read, understand and observe the safety instructions described in this manual.

Keep this manual or a copy of it with the machine. If you lose this manual or need an additional copy, please contact our Corporation. This machine is built with user safety in mind; however, it can present hazards if improperly operated and serviced. Follow operating instructions carefully! If you have questions about operating or servicing this equipment, please contact our Corporation.

The information contained in this manual was based on machines in production at the time of publication. Our Corporation reserves the right to change any portion of this information without notice.

All rights, especially copying and distribution rights, are reserved.

## 2. EMISSION CONTROL SYSTEM INFORMATION

### Source of Emissions

The combustion process produces carbon monoxide, oxides of nitrogen, and hydrocarbons. Control of hydrocarbons and oxides of nitrogen is very important because, under certain conditions, they react to form photochemical smog when subjected to sunlight. Carbon monoxide does not react in the same way, but it is toxic.

We utilizes lean carburetor settings and other systems to reduce the emissions of carbon monoxide, oxides of nitrogen, and hydrocarbons.

### The U.S. and California Clean Air Acts

EPA and California regulations require all manufacturers to furnish written instructions describing the operation and maintenance of emission control systems.

The following instructions and procedures must be followed in order to keep the emissions from the engine within the emissions standards.

### Tampering and Altering

Tampering with or altering the emission control system may increase emissions beyond the legal limit. Among those acts that constitute tampering are:

- Removal or alteration of any part of the intake, fuel, or exhaust systems.
- Altering or defeating the speed-adjusting mechanism to cause the engine to operate outside its design parameters.

## **Problems That May Affect Emissions**

If you are aware of any of the following symptoms, have your engine inspected and repaired by your servicing dealer.

- Hard starting or stalling after starting.
- Rough idle.
- Misfiring or backfiring under load.
- Afterburning (backfiring).
- Black exhaust smoke or high fuel consumption.

## **Replacement Parts**

The emission control systems on the engine were designed, built, and certified to conform with EPA and California emissions regulations. We recommend the use of genuine our parts whenever you have maintenance done. These original-design replacement parts are manufactured to the same standards as the original parts, so you can be confident of their performance. The use of replacement parts that are not of the original design and quality may impair the effectiveness of your emission control system.

A manufacturer of an aftermarket part assumes the responsibility that the part will not adversely affect emission performance. The manufacturer or rebuilder of the part must certify that use of the part will not result in a failure of the engine to comply with emission regulations.

## **Maintenance**

Follow the maintenance schedule. Remember that this schedule is based on the assumption that your machine will be used for its designed purpose. Sustained high-load or high-temperature operation, or use in unusually wet or dusty conditions, will require more frequent service.

## **OXYGENATED FUELS**

Some conventional gasolines are being blended with alcohol or an ether compound. These gasolines are collectively referred to as oxygenated fuels. To meet clean air standards, some areas of the United States and Canada use oxygenated fuels to help reduce emissions.

If you use an oxygenated fuel, be sure it is unleaded and meets the minimum octane rating

requirement.

Before using an oxygenated fuel, try to confirm the fuel's contents. Some States / Provinces require this information to be posted on the pump.

The following are EPA-approved percentages of oxygenates:

**ETHANOL** - (ethyl or grain alcohol) 10% by volume. You may use gasoline containing up to 10% ethanol by volume. Gasoline containing ethanol may be marketed under the name "Gasohol".

**MTBE** - (methyl tertiary butyl ether) 15% by volume. You may use gasoline containing up to 15% **MTBE** by volume.

**METHANOL** - (methyl or wood alcohol) 5% by volume. You may use gasoline containing up to 5% methanol by volume, as long as it contains cosolvents and corrosion inhibitors to protect the fuel system. Gasoline containing more than 5% methanol by volume may cause starting and/or performance problems. It may also damage metal, rubber, and plastic parts of your fuel system.

If you notice any undesirable operating symptoms, try another service station, or switch to another brand of gasoline.

Fuel system damage or performance problems resulting from the use of an oxygenated fuel containing more than the percentages of oxygenates mentioned above are not covered under warranty.

## **EMISSIONS COMPONENT DEFECT WARRANTY COVERAGE**

This emission warranty is applicable in all States.

Our Corporation, N92 W15000 Anthony Avenue, Menomonee Falls, WI 53051-1504, warrant("s") to the initial retail purchaser and each subsequent owner, that this non-road engine (herein "engine") has been designed, built, and equipped to conform at the time of initial sale to all applicable regulations of the U.S. Environmental Protection Agency (EPA), and that the engine is free of defects in materials and workmanship which would cause this engine to fail to conform with EPA regulations during its warranty period.

For the components listed under PARTS COVERED, the service dealer authorized by us will, at no cost to you, make the necessary diagnosis, repair, or replacement necessary to ensure that the engine complies with applicable U.S. EPA regulations.

## **EMISSION COMPONENT DEFECT WARRANTY PERIOD**

The warranty period for this engine begins on the date of sale to the initial purchaser and continues for a period of 2 years.

## **PARTS COVERED**

Listed below are the parts covered by the Emission Components Defect Warranty. Some of the parts listed below may require scheduled maintenance and are warranted up to the first scheduled replacement point for that part.

(1) Fuel Metering System

- (i) Carburetor and internal parts (and/or pressure regulator or fuel injection system).
- (ii) Air/fuel ratio feedback and control system, if applicable.
- (iii) Cold start enrichment system, if applicable.
- (iv) Regulator assembly (gaseous fuel, if applicable) .

(2) Air Induction System

- (i) Intake manifold, if applicable.
- (ii) Air filter.

(3) Ignition System

- (i) Spark plugs.
- (ii) Magneto or electronic ignition system.
- (iii) Spark advance/retard system, if applicable.

(4) Exhaust manifold, if applicable

(5) Miscellaneous Items Used in Above Systems

- (i) Electronic controls, if applicable.
- (ii) Hoses, belts, connectors, and assemblies.
- (iii) Filter lock assembly (gaseous fuel, if applicable).

## **OBTAINING WARRANTY SERVICE**

To obtain warranty service, take your engine to the nearest authorized our service dealer. Bring your sales receipts indicating date of purchase for this engine. The service dealer authorized by us will perform the necessary repairs or adjustments within a reasonable amount of time and furnish you with a copy of the repair order. All parts and accessories replaced under this warranty become the property of us.

## **WHAT IS NOT COVERED**

- Conditions resulting from tampering, misuse, improper adjustment (unless they were made by the service dealer authorized by us during a warranty repair), alteration, accident,

failure to use the recommended fuel and oil, or not performing required maintenance services.

- The replacement parts used for required maintenance services.
- Consequential damages such as loss of time, inconvenience, loss of use of the engine or equipment, etc.
- Diagnosis and inspection charges that do not result in warranty-eligible service being performed.
- Any non-authorized replacement part, or malfunction of authorized parts due to use of non-authorized parts.

## **OWNER'S WARRANTY RESPONSIBILITIES**

As the engine owner, you are responsible for the performance of the required maintenance listed in your owner's manual. We recommends that you retain all receipts covering maintenance on your engine, but we cannot deny warranty solely for the lack of receipts or for your failure to ensure the performance of all scheduled maintenance. As the engine owner, you should however be aware that we may deny warranty coverage if your engine or a part has failed due to abuse, neglect, improper maintenance or unapproved modifications.

You are responsible for presenting your engine to the nearest service dealer authorized by us when a problem exists.

If you have any questions regarding your warranty rights and responsibilities, you should contact the our CORPORATION Product Support Department for the information.

## **THINGS YOU SHOULD KNOW ABOUT THE EMISSION CONTROL SYSTEM WARRANTY:**

### **MAINTENANCE AND REPAIRS**

You are responsible for the proper maintenance of the engine. You should keep all receipts and maintenance records covering the performance of regular maintenance in the event questions arise. These receipts and maintenance records should be transferred to each subsequent owner of the engine. Our reserves the right to deny warranty coverage if the engine has not been properly maintained. Warranty claims will not be denied, however, solely because of the lack of required maintenance or failure to keep maintenance records.

MAINTENANCE, REPLACEMENT OR REPAIR OF EMISSION CONTROL DEVICES AND SYSTEMS MAY BE PERFORMED BY ANY REPAIR ESTABLISHMENT OR INDIVIDUAL; HOWEVER, WARRANTY REPAIRS MUST BE PERFORMED BY A SERVICE DEALER AUTHORIZED BY US. THE USE OF PARTS THAT ARE NOT EQUIVALENT IN PERFORMANCE AND DURABILITY TO AUTHORIZED PARTS MAY IMPAIR THE EFFECTIVENESS OF THE EMISSION CONTROL SYSTEM AND MAY HAVE A BEARING ON THE OUTCOME OF A WARRANTY CLAIM.

If other than the parts authorized by us are used for maintenance replacements or for the repair of components affecting emission control, you should assure yourself that such parts are warranted by their manufacturer to be equivalent to the parts authorized by us in their performance and durability.

## HOW TO MAKE A CLAIM

All repair qualifying under this limited warranty must be performed by a service dealer authorized by us. In the event that any emission-related part is found to be defective during the warranty period, you shall notify our CORPORATION Product Support Department

## 3. SAFETY INFORMATION

This manual contains DANGER, WARNING, CAUTION, and NOTE callouts which must be followed to reduce the possibility of personal injury, damage to the equipment, or improper service.



This is the safety alert symbol. It is used to alert you to potential personal injury hazards. Obey all safety messages that follow this symbol to avoid possible injury or death.



**DANGER** indicates a hazardous situation which, if not avoided, will result in death or serious injury.



**WARNING** indicates a hazardous situation which, if not avoided, could result in death or serious injury.



**CAUTION** indicates a hazardous situation which, if not avoided, could result in minor or moderate injury.

**CAUTION:** Used without the safety alert symbol, CAUTION indicates a potentially hazardous situation which, if not avoided, may result in property damage.

**Note:** *Contains additional information important to a procedure.*

### 3.1 Operating Safety



Familiarity and proper training are required for the safe operation of equipment. Equipment operated improperly or by untrained personnel can be dangerous. Read the operating instructions contained in both this manual and the engine manual and familiarize yourself with the location and proper use of all controls. Inexperienced operators should receive instruction from someone familiar with the equipment before being allowed to operate the machine.

3.1.1 **NEVER** operate this machine in applications for which it is not intended.

3.1.2 **NEVER** allow anyone to operate this equipment without proper training. People

operating this equipment must be familiar with the risks and hazards associated with it.

- 3.1.3 **NEVER** touch the engine or muffler while the engine is on or immediately after it has been turned off. These areas get hot and may cause burns.
- 3.1.4 **NEVER** use accessories or attachments that are not recommended by us. Damage to equipment and injury to the user may result.
- 3.1.5 **NEVER** leave machine running unattended.
- 3.1.6 **NEVER** tamper with or disable the function of operating controls.
- 3.1.7 **NEVER** use choke to stop engine.
- 3.1.8 **NEVER** operate the machine in areas where explosions may occur.
- 3.1.9 **ALWAYS** read, understand, and follow procedures in the **Operator's Manual** before attempting to operate the equipment.
- 3.1.10 **ALWAYS** be sure that all other persons are at a safe distance from the machine. Stop the machine if people step into the working area of the machine.
- 3.1.11 **ALWAYS** be sure operator is familiar with proper safety precautions and operation techniques before using machine.
- 3.1.12 **ALWAYS** wear protective clothing appropriate to the job site when operating equipment.
- 3.1.13 **ALWAYS** wear hearing protection when operating equipment.
- 3.1.14 **ALWAYS** keep hands, feet, and loose clothing away from moving parts of the machine.
- 3.1.15 **ALWAYS** use common sense and caution when operating the machine.
- 3.1.16 **ALWAYS** be sure the rammer will not tip over, roll, slide, or fall when not being operated.
- 3.1.17 **ALWAYS** turn the engine **OFF** when the rammer is not being operated.
- 3.1.18 **ALWAYS** guide the rammer in such a way that the operator is not squeezed between the rammer and solid objects. Special care is required when working on uneven ground or when compacting coarse material. Make sure to stand firmly when operating the machine under such conditions.
- 3.1.19 **ALWAYS** operate the rammer in such a way that there is no danger of it turning over or falling in, when working near the edges of breaks, pits, slopes, trenches and platforms.

- 3.1.20 **ALWAYS** store the equipment properly when it is not being used. Equipment should be stored in a clean, dry location out of the reach of children.
- 3.1.21 **ALWAYS** close fuel valve on engines equipped with one when machine is not being operated.
- 3.1.22 **ALWAYS** operate machine with all safety devices and guards in place and in working order. **DO NOT** modify or defeat safety devices. **DO NOT** operate machine if any safety devices or guards are missing or inoperative.

## 3.2 Operator Safety while using Internal Combustion Engines



Internal combustion engines present special hazards during operation and fueling. Read and follow the warning instructions in the engine owner's manual and the safety guidelines below. Failure to follow the DANGER warnings and safety guidelines could result in severe injury or death.

- 3.2.1 **DO NOT** smoke while operating the machine.
- 3.2.2 **DO NOT** smoke when refueling the engine.
- 3.2.3 **DO NOT** refuel a hot or running engine.
- 3.2.4 **DO NOT** refuel the engine near an open flame.
- 3.2.5 **DO NOT** spill fuel when refueling the engine.
- 3.2.6 **DO NOT** run the engine near open flames.
- 3.2.7 **DO NOT** run the machine indoors or in an enclosed area such as a deep trench unless adequate ventilation, through such items as exhaust fans or hoses, is provided. Exhaust gas from the engine contains poisonous carbon monoxide gas; exposure to carbon monoxide can cause loss of consciousness and may lead to death.
- 3.2.8 **ALWAYS** refill the fuel tank in a well-ventilated area.
- 3.2.9 **ALWAYS** replace the fuel tank cap after refueling.
- 3.2.10 **ALWAYS** check the fuel lines and the fuel tank for leaks and cracks before starting the engine. Do not run the machine if fuel leaks are present or the fuel lines are loose.

## 3.3 Service Safety



Poorly maintained equipment can become a safety hazard! In order for the equipment to operate safely and properly over a long period of time, periodic maintenance and occasional repairs are necessary.

- 3.3.1 **DO NOT** attempt to clean or service the machine while it is running. Rotating parts can cause severe injury.
- 3.3.2 **DO NOT** operate the machine without an air cleaner.
- 3.3.3 **DO NOT** remove air cleaner cover, paper element, or precleaner while engine is running.
- 3.3.4 **DO NOT** alter engine speeds. Run the engine only at speeds specified in the Technical Data Section.
- 3.3.5 **DO NOT** crank a flooded engine with the spark plug removed on gasoline-powered engines. Fuel trapped in the cylinder will squirt out the spark plug opening.
- 3.3.6 **DO NOT** test for spark on gasoline-powered engines if the engine is flooded or the smell of gasoline is present. A stray spark could ignite the fumes.
- 3.3.7 **DO NOT** use gasoline or other types of fuels or flammable solvents to clean parts, especially in enclosed areas. Fumes from fuels and solvents can become explosive.
- 3.3.8 **ALWAYS** replace the safety devices and guards after repairs and maintenance.
- 3.3.9 **ALWAYS** keep the area around the muffler free of debris such as leaves, paper, cartons, etc. A hot muffler could ignite the debris and start a fire.
- 3.3.10 **ALWAYS** do Periodic Maintenance as recommended in the Operator's Manual.
- 3.3.11 **ALWAYS** clean debris from engine cooling fins.
- 3.3.12 **ALWAYS** replace worn or damaged components with spare parts designed and recommended by us Corporation.
- 3.3.13 **ALWAYS** disconnect the spark plug on machines equipped with gasoline engines, before servicing, to avoid accidental start-up.
- 3.3.14 **ALWAYS** keep the machine clean and labels legible. Replace all missing and hard-to-read labels. Labels provide important operating instructions and warn of dangers and hazards.



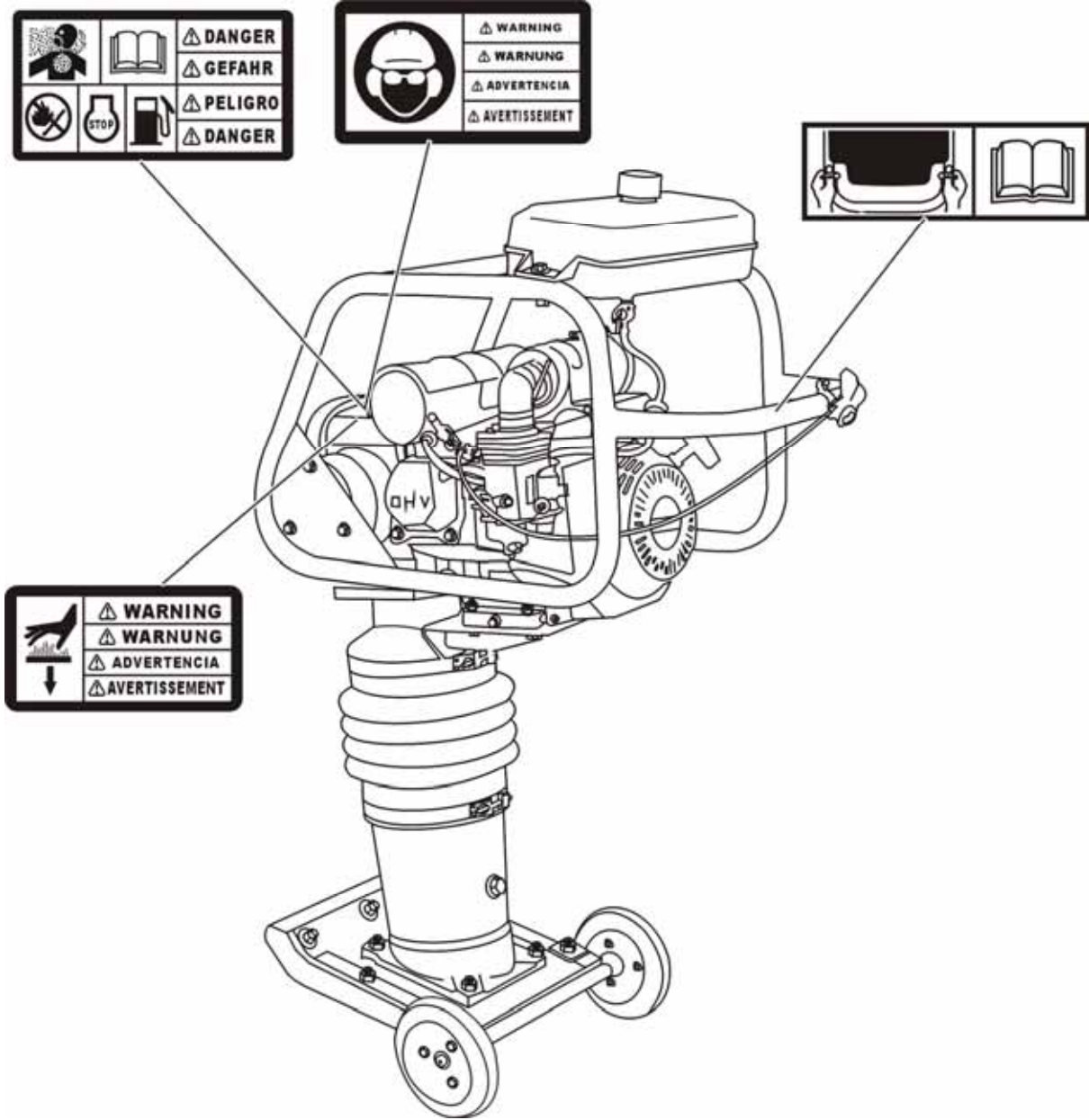



### 3.4 Label Locations





Graphic 1

### 3.5 Safety Labels

The machines use international pictorial labels where needed. These labels are described below:

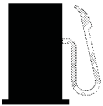

Label	Meaning
	<p>This molded-in label contains important safety and operating information. If it becomes illegible, the cover must be replaced. Refer to the Parts Book for ordering information.</p>
	<p><b>DANGER!</b> Engines emit carbon monoxide; operate only in well-ventilated area.</p>
	<p>Read the operator's manual for machine information.</p>
	<p><b>DANGER!</b> No sparks, flames or burning objects near machine.</p>
	<p>Shut off the engine before refueling.</p>
	<p><b>CAUTION!</b> Use only clean, filtered gasoline fuel.</p>

Label	Meaning
	<p><b>WARNING!</b> Hot surface!</p>
	<p>For optimal control, performance, and minimal hand/arm vibration, grasp handle as shown.</p> <p>Refer to Section Proper Operation for further details.</p>
<p>GASOLINE BENZIN GASOLINA ESSENCE</p> 	<p><b>CAUTION!</b> Use only clean, filtered gasoline fuel.</p>

### 3.6 Operating Labels

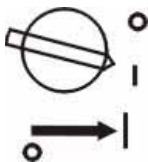
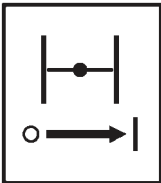
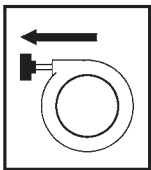
The machines use international pictorial labels where needed. These labels are described below:

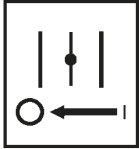
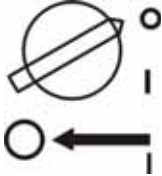
Label	Meaning
	<p>Turn the engine switch to the ON position.</p>
	<p>Close the choke.</p>
	<p>Pull the rewind starter.</p>

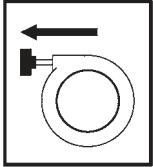
	Open the choke.
	Turn the engine switch to "OFF".
	Throttle control lever: Turtle = Idle or Slow Rabbit = Full or Fast
	Open fuel flow valve.
	Pull rewind starter.

## 4. TECHNICAL DATA

### 4.1 Rammer

Model		PDR80
Engine Model	type	168F
Engine Speed - full	rpm	3600 ± 100
Engine Speed - idle	rpm	1450 ± 100
Clutch Engagement	rpm	2000 ± 100
Spark Plug	type	(NGK) BPR6ES, F7RTC
Electrode Gap	mm (in)	0.6–0.7 (0.002–0.030)
Cylinder Head Compression (cold)	bar/cm <sup>3</sup> (psi)	8.0–9.7 (120–140)
Air Cleaner	type	Three stage with cyclonic precleaner
Engine Lubrication	oil grade	SAE 10W30 SE, SF or higher
Engine Oil Capacity	L (oz.)	0.6 (20)
Fuel Tank Capacity	L (qts.)	3.6 (4.0)
Fuel	type	Regular unleaded gasoline
Fuel Consumption	L(qt.)/hr	1.2 (1.3)
Running Time	hour	2.5
Ramming Lubrication System	oil grade	SAE 10W30
Ramming Capacity System	L (oz.)	0.9(30)

## **4.2 Sound Measurements**

Products are tested for sound pressure level in accordance with EN ISO 11204. Sound power level is tested in accordance with European Directive 2000/14/EC - Noise Emission in the Environment by Equipment for use outdoors.

- the sound pressure level at operator's location (LpA) = 98 dB(A).
- the guaranteed sound power level (LWA) = 108 dB(A).

## **4.3 Vibration Measurements**

Products are tested for hand/arm vibration (HAV) level in accordance with ISO 5349, EN1033, and EN500-4 where applicable.

- HAV 6.5 m/s<sup>2</sup> Refer to Section Proper Operation for further details.

## 5. OPERATION

### 5.1 Application

Rammers are designed to compact loose soils and gravel to prevent settling and to provide a firm, solid base for the placement of footings, concrete slabs, foundations, and other structures.

### 5.2 Recommended Fuel

This engine is certified to operate on automotive unleaded gasoline. Use only fresh, clean gasoline. Gasoline containing water or dirt will damage fuel system.

### 5.3 Before Starting

- 5.3.1 Read safety instructions at the beginning of this manual.
- 5.3.2 Make sure that the gas tank is full.
- 5.3.3 Check engine oil level.
- 5.3.4 Place rammer on loose soil or gravel. **DO NOT** start rammer on hard surfaces such as asphalt or concrete.

### 5.4 To Start

*See Graphic 2*

**Note:** *After transporting the rammer horizontally, upright the rammer and allow the oil to drain back through the engine. It may take up to 2 minutes for the oil level to recover.*

- 5.4.1 Open fuel valve (e).
- 5.4.2 Turn engine switch to "ON" (d).
- 5.4.3 If the engine is cold, close choke (b1) on the carburetor.

**Note:** Occasionally, warm engines will need to be choked.

- 5.4.4 With throttle in idle position (c3), pull the starter rope (a) until the engine starts.
- 5.4.5 On engines equipped with the low oil shutoff switch, see section Low Oil Shutoff Switch for additional information.

**Note:** *First time use, engines recently serviced, run out of fuel or not used for long periods of time may need the rope to be pulled more times to move fuel to the carburetor.*

- 5.4.6 Open choke (b2) on the carburetor as the engine warms up.

**Note:** *A cold engine should be allowed to warm up at the idle position (c2) for*

approximately one (1) minute. Failure to open the choke after the engine attempts to start may cause flooding.

**CAUTION:** Always open choke (b2) with throttle in idle position (c3). Opening choke with throttle not in idle position (c3) may result in rammer motion.

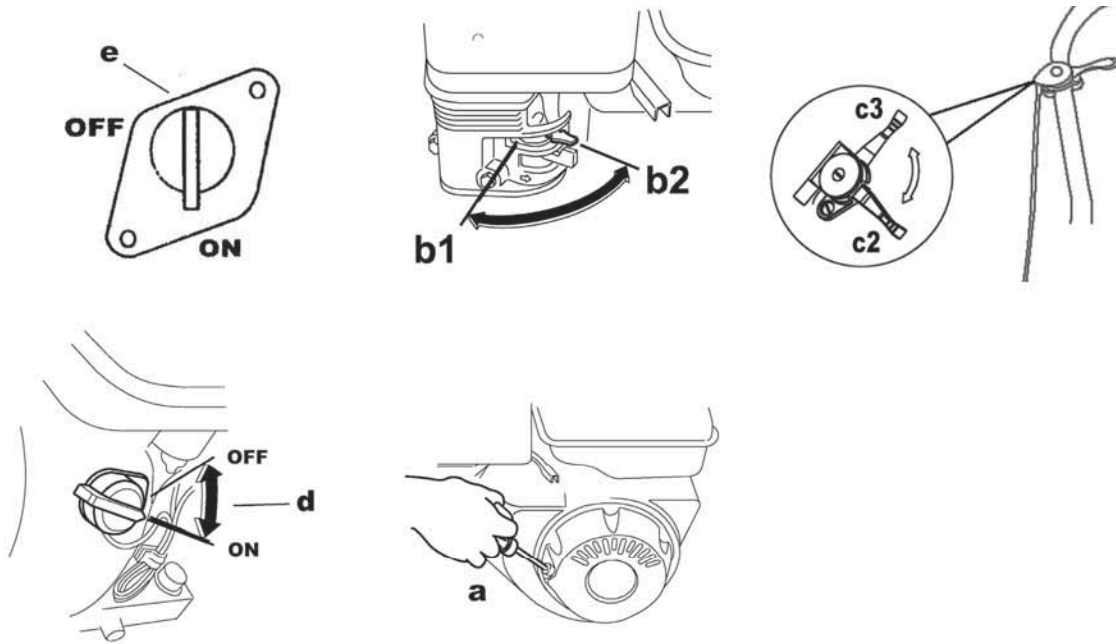

**Graphic 2**

## 5.5 To Stop

See *Graphic 2*

- 5.5.1 Place throttle in the idle position (c3).
- 5.5.2 Turn engine switch to "OFF" (d).
- 5.5.3 Close fuel valve (e).

## 5.6 Low Oil Shutoff Switch (if equipped)

The low oil shutoff switch is designed to prevent engine damage caused by an insufficient amount of oil.

When starting the machine:

- if the warning light flashes quickly once, this indicates the engine oil level is acceptable.
- if the warning light flashes slowly, the engine will start but shut off after 10-12 seconds, this indicates that the engine oil level is low. Add oil to the engine. See Technical Data for oil quantity and type.

- if the warning light stays on continuously, the engine will start and continue to run but the low oil shutoff switch is not functioning properly. Check the switch for proper wire connections. If the light continues to stay on, replace the switch.

- if the warning light does not flash quickly once, and the engine starts and continues to run, the low oil shutoff switch is not functioning properly. Check the switch for proper wire connections and grounding. If the light still does not flash when starting the machine, replace the switch.

## 5.7 Proper Operation

*See Graphic 3*

Keep vibratory rammer clean and dry. Avoid no-load strokes. Never allow the rammer to run full throttle when forcing away material or when lifting the equipment.

For optimal control, performance, and minimal hand/arm vibration, grasp handle as shown. Hand/arm vibration (HAV) has been optimized for this positioning. Reported HAV levels are measured at position A just in front of the hand position shown in conformance with EN1033 and ISO 5349.

**CAUTION:** To prevent damage to the rammer, do not allow the rammer to run on its side.

If the rammer should tip on its side, place the rammer in the position shown, then shut off the engine by turning engine switch to "**OFF**".

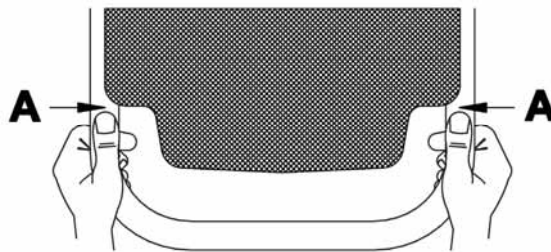

**Graphic 3**

## 5.8 Proper Compaction

*See Graphic 4*

5.8.1 Run rammer at the full throttle position (a2) for maximum performance.

5.8.2 Guide rammer with its handle. Allow machine to pull itself forward. DO NOT try to over-power the machine.

5.8.3 For best compaction, the shoe must hit the ground flat (b), not on its toe or heel. This will save on excessive shoe wear.

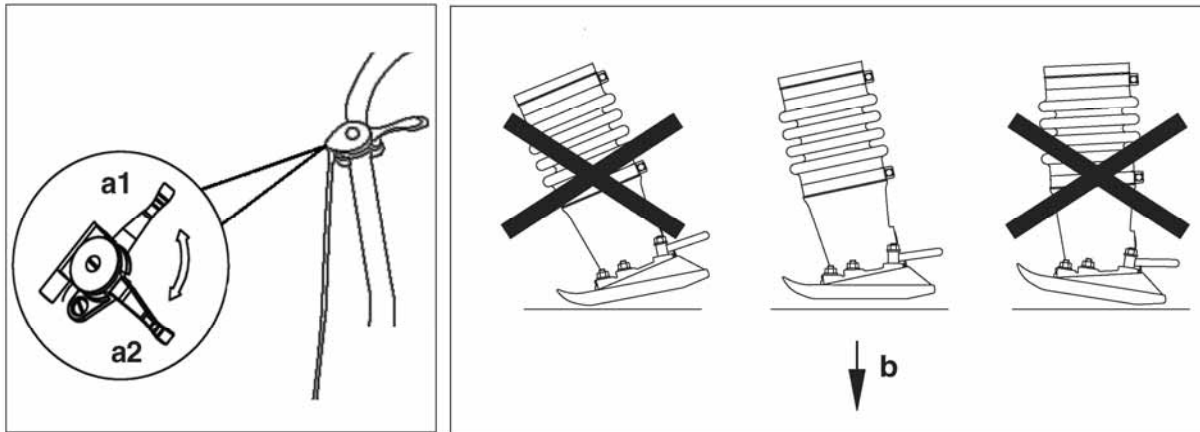

Graphic 4

## 6. MAINTENANCE

### 6.1 Periodic Maintenance Schedule

Maintenance, replacement, or repair of the emission control devices and systems may be performed by any non-road engine repair establishment or individual.

	Daily before starting	After first 5 hours	Every week or 25 hours	Every month or 100 hours	Every 3 months or 300 hours	Every Year
Check fuel level. Check engine oil level.	●					
Inspect air filter. Replace as needed.	●					
Check oil level in sightglass.	●					
Check fuel line and fittings for cracks or leaks. Replace as needed.	●					
Tighten ramming shoe hardware.		●	●			
Check external hardware.		●	●			
Clean engine cooling fins.			●			
Clean and check spark plug gap.			●			

Change engine oil.				●		
Replace spark plug.				●		
Clean recoil starter.					●	
Change ramming system oil.*					●	
Inspect crane lifting cable for wear, damage, or abuse.					●	
Inspect fuel filter.						●
<p>● Change ramming system oil after first 50 hours of operation.  <b>Note:</b> <i>If engine performance is poor, check, clean, and replace air filter elements as needed.</i></p>						

## 6.2 Servicing Air Cleaner

See Graphic 5

The engine is equipped with a dual element air cleaner. Service air cleaner frequently to prevent carburetor malfunction.

**CAUTION: NEVER** run engine without air cleaner. Severe engine damage will occur.



**WARNING: NEVER** use gasoline or other types of low flash point solvents for cleaning the air cleaner. A fire or explosion could result.

To service:

- 6.2.1 Release the retaining clip, and remove the air cleaner cover.
- 6.2.2 Remove and inspect the air filter elements. If the air filter element is dirty, clean the air filter elements as described below. Replace damaged filter elements. Always replace the paper air filter element at the scheduled interval.
- 6.2.3 Place the foam air filter element over the paper element, and reinstall the assembled air filter elements. Insert the open end of the air filter elements into the case as shown, so the closed end is toward the air cleaner cover.
- 6.2.4 Hook the bottom edge of the air cleaner cover onto the case, then secure the cover with the retaining clip.

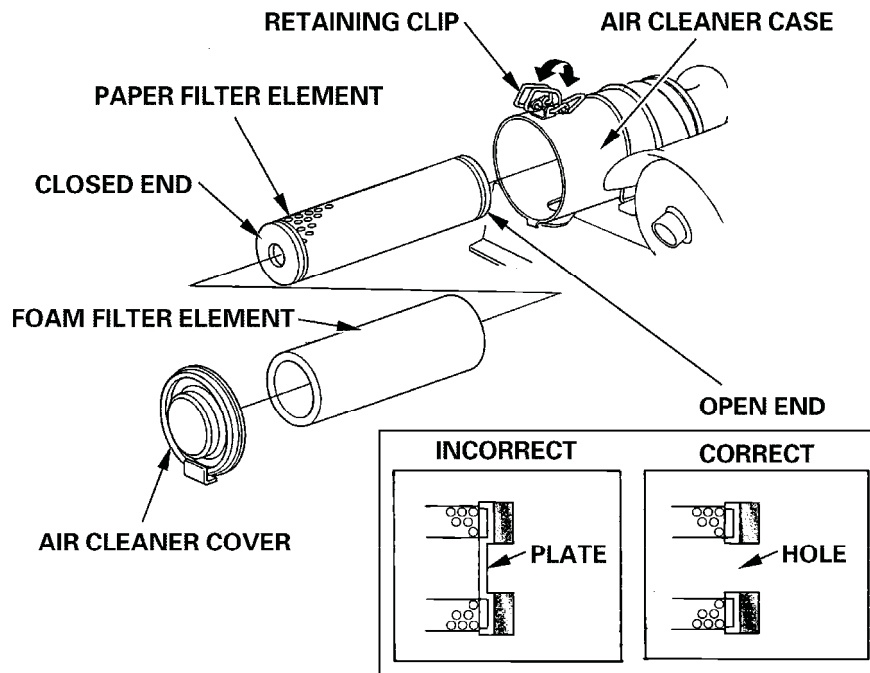

**Graphic 5**

### 6.2.5 Cleaning:

#### 6.2.5.1. Clean the air filter elements if they are to be reused.

Paper air filter element: Tap the filter element several times on a hard surface to remove dirt, or blow compressed air [not exceeding 207 kPa (2.1 kgf/cm<sup>2</sup>, 30 psi)] through the filter element from the inside. Never try to brush off dirt; brushing will force dirt into the fibers.

Foam air filter element: Clean in warm soapy water, rinse, and allow to dry thoroughly. Or clean in non-flammable solvent and allow to dry. Dip the filter element in clean engine oil, then squeeze out all excess oil. The engine will smoke when started if too much oil is left in the foam.

#### 6.2.5.2. Wipe dirt from the inside of the air cleaner case and cover, using a moist rag. Be careful to prevent dirt from entering the air duct that leads to the carburetor.

## 6.3 Engine Oil

*See Graphic 6*

### 6.3.1 Drain oil while engine is still warm.

**Note:** In the interests of environmental protection, place a plastic sheet and a container under the machine to collect any liquid which drains off. Dispose of this liquid in accordance with environmental protection legislation.

### 6.3.2 Place the rammer so it is resting on its shoe on a level surface.

- 6.3.3 Remove the oil fill plug (a) and drain plug (b) to drain oil.
- 6.3.4 Install the drain plug (b).
- 6.3.5 Fill the engine crankcase with recommended oil up to the level of the plug opening (c). Do not thread in the dipstick to check the level. See Technical Data for oil quantity and type.
- 6.3.6 Install the oil filler plug (a).

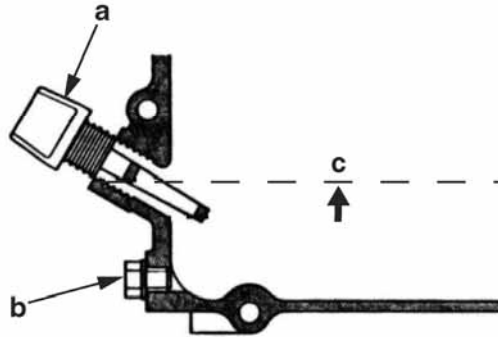

Graphic 6

## 6.4 Lubrication

*See Graphic 7*

### Ramming system

#### Check oil level:

- 6.4.1 Place the rammer so it is resting on its shoe on a level surface.
- 6.4.2 Check the oil level through oil sightglass (d). Proper ramming system lubrication is indicated when approximately 1/2–3/4 of the sightglass is full.
- 6.4.3 If the oil is not visible, oil must be filled through the filling oil mouth(f), then see the technical Data for oil quantity and type through oil sightglass (d).
- 6.4.4 Wrap the filling oil plug with Teflon tape. Install the filling oil plug (f). Torque to 9 Nm.

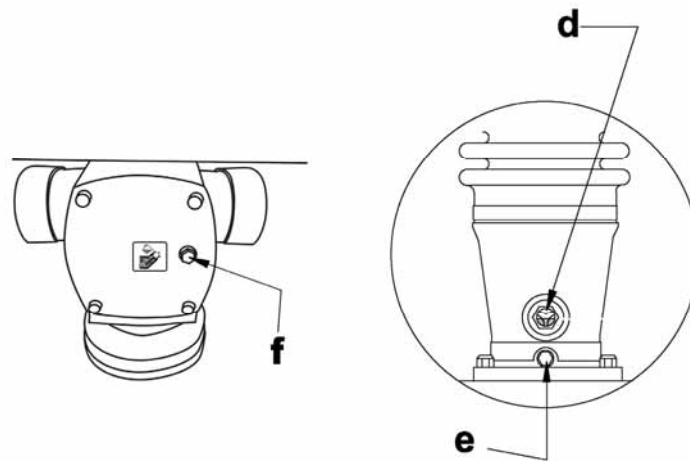

**Graphic 7**

### **Oil change:**

6.4.5 Unscrew the oil drain plug (e) located below the oil sightglass.

6.4.6 Tip the rammer back until it is resting on its handle and allow oil to drain.

**Note:** In the interests of environmental protection, place a plastic sheet and a container under the machine to collect any liquid which drains off. Dispose of this liquid in accordance with environmental protection legislation.

6.4.7 Screw in the oil drain plug (e). Torque to 54 Nm.

6.4.8 Remove filling oil plug (f) and fill with oil. See Technical Data for oil quantity and type. Wrap the filling oil plug with teflon tape. Install the filling oil plug (f). Torque to 9 Nm.

### **6.5 Shoe Hardware**

*See Graphic 8*

On new machines, or after replacing shoe, check and tighten shoe hardware (a) after the first 5 hours of operation. Inspect hardware every week thereafter.

Torque hardware as specified.

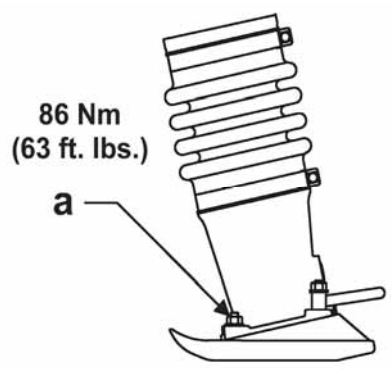

**Graphic 8**

## 6.6 Long-Term Storage

- 6.6.1 Drain fuel from tank.
- 6.6.2 Start engine and run until remaining fuel is used.
- 6.6.3 Remove spark plug. Pour approximately 30 ml (1 oz.) of clean SAE 10W30 engine oil into cylinder through spark plug opening.
- 6.6.4 Pull starter rope slowly to distribute oil in engine.
- 6.6.5 Re-install spark plug.

## 6.7 Troubleshooting

Problem / Symptom	Reason / Remedy
Engine does not start, or stalls.	<ul style="list-style-type: none"> <li>• No fuel in tank.</li> <li>• Check engine oil level.</li> <li>• Spark plug fouled.</li> <li>• Fuel valve closed.</li> <li>• Engine switch is in the "OFF" position.</li> </ul>
Engine does not accelerate, is hard to start, or runs erratically.	<ul style="list-style-type: none"> <li>• Spark plug fouled.</li> <li>• Crankshaft seals are leaking.</li> <li>• Check air cleaner.</li> <li>• Check engine oil level.</li> </ul>

Engine overheats.	<ul style="list-style-type: none"> <li>• Clean cooling fins and fan blades.</li> </ul>
Engine runs, rammer does not tamp.	<ul style="list-style-type: none"> <li>• Inspect clutch for damage. Replace if necessary.</li> <li>• Broken connecting rod or crankgear.</li> <li>• Low engine performance. Compression loss.</li> </ul>
Engine runs, rammer operation is erratic.	<ul style="list-style-type: none"> <li>• Oil/grease on clutch.</li> <li>• Broken/worn springs.</li> <li>• Soil buildup on ramming shoe.</li> <li>• Broken parts in ramming system or crankcase.</li> <li>• Engine operating speed is too high.</li> </ul>
On machines equipped with the low oil shutoff switch, the warning light flashes slowly, the engine starts but shuts off after 10-12 seconds.	<ul style="list-style-type: none"> <li>• Engine oil level is low. Add oil to the engine. See <i>Technical Data</i> for oil quantity and type.</li> </ul>

Problem / Symptom	Reason / Remedy
On machines equipped with the low oil shutoff switch, the engine starts and continues to run but the low oil warning light stays on continuously.	<ul style="list-style-type: none"> <li>• Check the switch for proper wire connections.</li> <li>• Switch is not functioning properly. Replace the switch.</li> </ul>
On machines equipped with the low oil shutoff switch, the engine starts and continues to run, but the low oil warning light did not flash quickly once.	<ul style="list-style-type: none"> <li>• Check the switch for proper wire connections and grounding.</li> <li>• Switch is not functioning properly. Replace the switch.</li> </ul>