

# **PD210E**

## **GASOLINE GENERATOR / WELDER**

### **Owner's Manual**

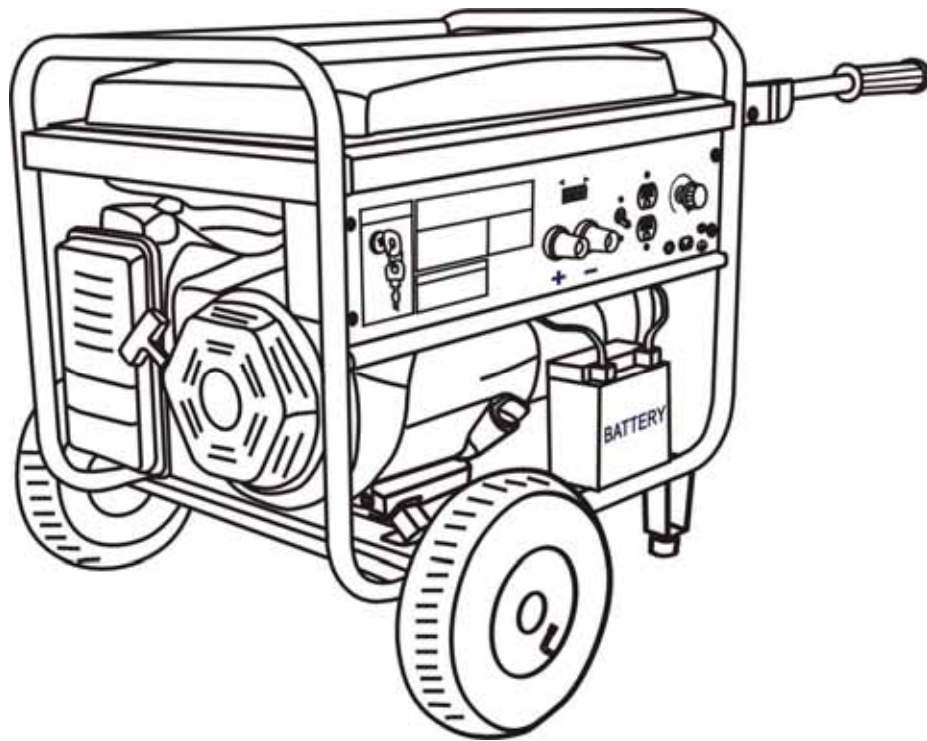

**SAVE THIS MANUAL FOR FUTURE REFERENCE**

This manual provides information regarding the operation and maintenance of these products. We have made every effort to ensure the accuracy of the information in this manual. We reserve the right to change this product at any time without prior notice.

Please keep this manual available to all users during the entire life of the generator/welder.

**WARNING:**

The engine exhaust from this product contains chemicals known to the State of California to cause cancer, birth defects or other reproductive harm.

**WARNING:**

**The generator is a potential source of electrical shock if misused. Do not expose the generator to moisture, rain or snow. Do not let the generator get wet, and do not operate it with wet hands.**

Keep this owner's manual handy, so you can refer to it at any time. This owner's manual is considered a permanent part of the generator and should remain with the generator if resold.

The information and specifications included in this publication were in effect at the time of approval for printing. Our company reserves the right, however, to discontinue or change specifications or design at any time without notice and without incurring any obligation whatever. No part of this publication may be reproduced without written permission.

Congratulations on your selection of our generator/Welder. We are certain you will be pleased with your purchase of one of the finest generators/Welders on the market.

We want to help you get the best results from your new generator/welder and to operate it safely. This manual contains the information on how to do that, please read it carefully.

As you read this manual, you will find information preceded by a symbol. That information is intended to help you avoid damage to your generator/welder, other property, or the environment.

We suggest you read the warranty policy to fully understand its coverage and your responsibilities of ownership. The warranty policy is a separate document that should have been given to you by your dealer.

When your generator/Welder needs scheduled maintenance, keep in mind that your our servicing dealer is specially trained in servicing our generators/welders. Your authorized our servicing dealer is dedicated to your satisfaction and will be pleased to answer your questions and concerns.

## **A FEW WORDS ABOUT SAFETY**

Your safety and the safety of others is very important. And using this generator/Welder safely is an important responsibility.

To help you make informed decisions about safety, we have provided operating procedures and other information on labels and in this manual. This information alerts you to potential hazards that could hurt you or others.

Of course, it is not practical or possible to warn you about all the hazards associated with operating or maintaining a generator/Welder. You must use your own good judgment.

You will find important safety information in a variety of forms, including;

- **Safety Labels** — on the generator/Welder.
- **Safety Messages** — Preceded by a safety alert symbol and one of three signal words, DANGER, WARNING, or CAUTION.

These signal words mean:

**DANGER:** You WILL be KILLED or SERIOUSLY HURT if you don't follow instructions.

**WARNING:** You WILL be KILLED or SERIOUSLY HURT if you don't follow instructions.

**CAUTION:** You CAN be HURT if you don't follow instructions.

- **Safety Headings** — such as IMPORTANT SAFETY INFORMATION.
- **Safety Section** — such as GENERATOR/WELDER SAFETY.
- **Instructions** — how to use this generator/Welder correctly and safely.

This entire book is filled with important safety information — please read it carefully.

# CONTENTS

SAFETY .....	1
Safety Label Locations .....	1
Safety Information .....	1
COMPONENT IDENTIFICATION .....	3
CONTROLS .....	4
Engine Switch .....	4
Recoil Starter .....	4
Fuel Valve Lever .....	5
Choke Rod .....	5
Circuit Breaker .....	5
Oil Alert System .....	6
DC Receptacle .....	6
AC/DC (Weld) Selector Switch.....	6
Welding Cable Terminal .....	7
Welding Current Adjust System .....	7
GENERATOR/WELDER USE .....	8
Connections to a Building Electrical System.....	8
AC Operation .....	8
Welding .....	9
Selecting the Correct Welding Current.....	10
Welding Cable Selection .....	10
Welding Duty Cycle.....	10
Polarity Selection.....	10
High Altitude Operation .....	11
PRE-OPERATION CHECK.....	12
Engine Oil .....	12
Fuel Recommendation .....	12
STARTING THE ENGINE/STOPPING THE ENGINE .....	15
MAINTENANCE .....	16
The Importance of Maintenance .....	16
Maintenance Safety .....	16
Emission Control System Information .....	17
Air Index .....	18
Maintenance Schedule .....	19
Engine Oil Change .....	19
Air Cleaner Service .....	20
Fuel Sediment Cup Cleaning .....	21
Spark Plug Service .....	21
TRANSPORTING/STORAGE.....	23
WIRING DIAGRAM .....	25
SPECIFICATIONS .....	26
WHEEL LIT .....	27

## **SAFETY LABEL LOCATIONS**

These labels warn you of potential hazards that can cause serious injury. Read them carefully. If a label comes off or becomes hard to read, contact your Generator dealer for a replacement.

## **SAFETY INFORMATION**

Our generator/welders are designed to give safe and dependable service if operated according to instructions. Read and understand this owner's manual before operating your generator/welder. You can help prevent accidents by being familiar with your generator/welder's controls, and by observing safe operating procedures.

### **Operator Responsibility**

- Know how to stop the generator/welder quickly in case of emergency.
- Understand the use of all generator/welder controls, output receptacles, and connections.
- Be sure that anyone who operates the generator/welder receives proper instruction. Do not let children operate the generator/welder without parental supervision.

### **Carbon Monoxide Hazards**

- Exhaust contains poisonous carbon monoxide, a colorless and odorless gas. Breathing exhaust can cause loss of consciousness and may lead to death.
- If you run the generator/welder in an area that is confined, or even partially enclosed, the air you breathe could contain a dangerous amount of exhaust gas. To keep exhaust gas from building up, provide adequate ventilation.

### **Electric Shock Hazards**

- The generator/welder produces enough electric power to cause a serious shock or electrocution if misused.
- Using a generator/welder or electrical appliance in wet conditions, such as rain or snow, or near a pool or sprinkler system, or when your hands are wet, could result in electrocution. Keep the generator/welder dry.
- If the generator/welder is stored outdoors, unprotected from the weather, check all electrical components on the control panel, before each use. Moisture or ice can cause a malfunction or short circuit in electrical components which could result in electrocution.
- Do not connect to a building's electrical system unless an isolation switch has been installed by a qualified electrician.

### **Fire and Burn Hazards**

- The exhaust system gets hot enough to ignite some materials.
  - Keep the generator/welder at least 1 meter (3 feet) away from buildings and other equipment during operation.
  - Do not enclose the generator/welder in any structure.

- Keep flammable materials away from the generator/welder.
- The muffler becomes very hot during operation and remains hot for a while after stopping the engine. Be careful not to touch the muffler while it is hot. Let the engine cool before storing the generator/welder indoors.
- Gasoline is extremely flammable and is explosive under certain conditions. Do not smoke or allow flames or sparks where the generator/welder is refueled or where gasoline is stored. Refuel in a well-ventilated area with the engine stopped.
- Fuel vapors are extremely flammable and may ignite after the engine has started. Make sure that any spilled fuel has been wiped up before starting the generator/welder.
- Use adequate eye protection. Eye protection is of the utmost importance, not only for the operator, but also for any other personnel in the vicinity while welding is being done. Eye hazards include arc glare, reflected glare, stray flashes, sparks, and flying bits of molten metal.
- Looking at a welding arc with unprotected eyes may produce severe pain and even temporary blindness.
- Use a helmet or hand-held shield with a #10 or darker filter lens. Filter lenses eliminate the harmful effects of infrared and ultraviolet radiation from the arc and reduce the glare from the arc light as well.
- Wear protective clothing such as leather gloves, cap, sleeves, jacket, apron, and high-top safety shoes. All outer clothing must be free of oil and grease.

**FACE SHIELD**

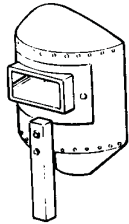

**GLOVES**



**SAFETY SHOES**



**APRON**

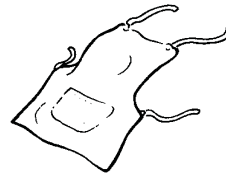

## **COMPONENT IDENTIFICATION**

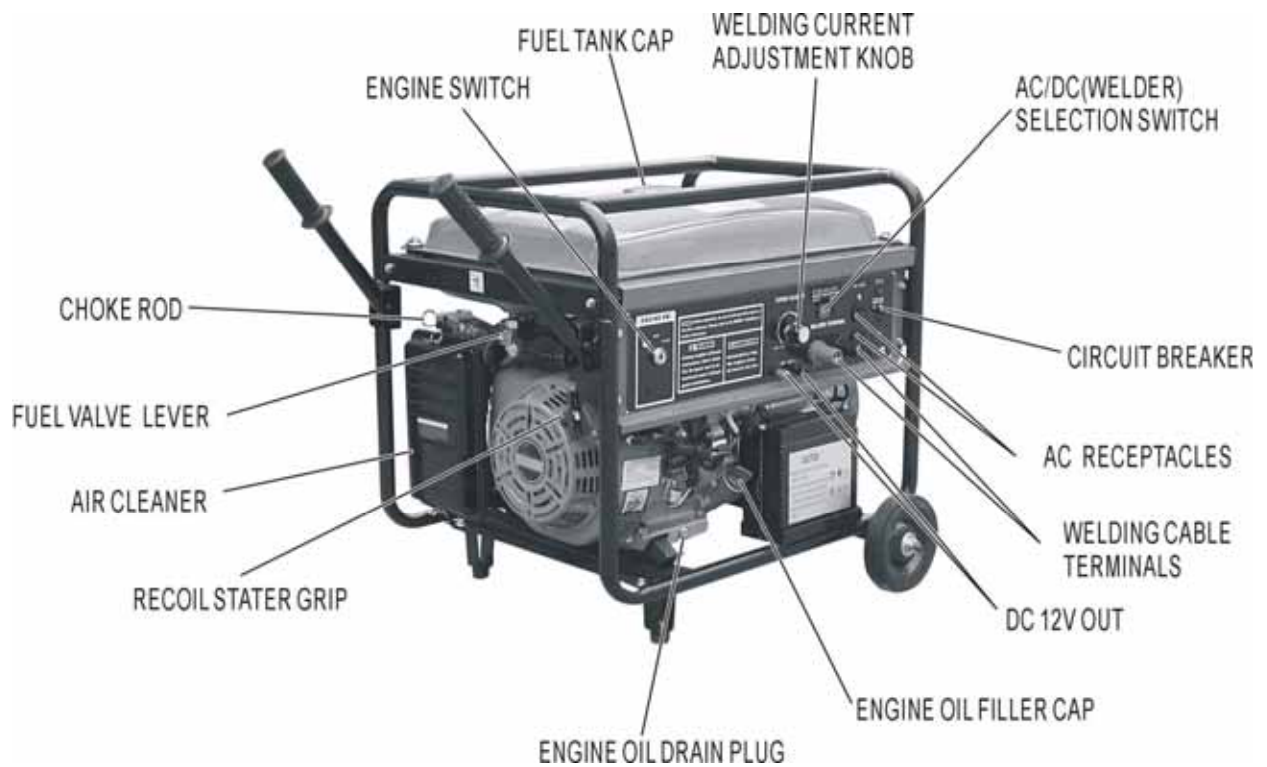

- Record the engine and frame serial numbers for your future reference. Refer to these serial numbers when ordering parts, and when making technical or warranty inquiries.

## **CONTROLS**

---

### **Engine Switch**

To start and stop the engine.

**Switch position:**

**OFF:** To stop the engine.

**ON:** To run the engine.

### **ENGINE SW.**

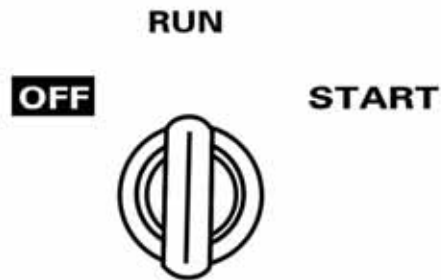

### **Recoil Starter**

To start the engine, pull the starter grip lightly until resistance is felt, then pull briskly.

#### **NOTICE:**

*Do not allow the starter grip to snap back against the engine. Return it gently to prevent damage to the starter.*

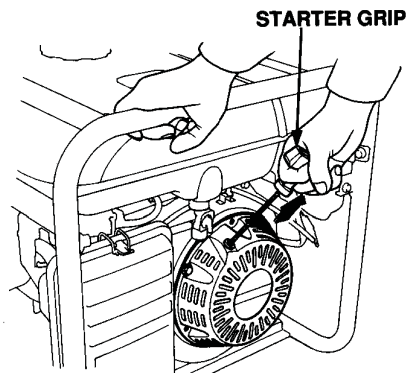

## Fuel Valve Lever

The fuel valve is located between the fuel tank and carburetor. When the fuel valve lever is in the ON position, fuel is allowed to flow from the fuel tank to the carburetor. Be sure to return the fuel lever to the OFF position after stopping the engine.

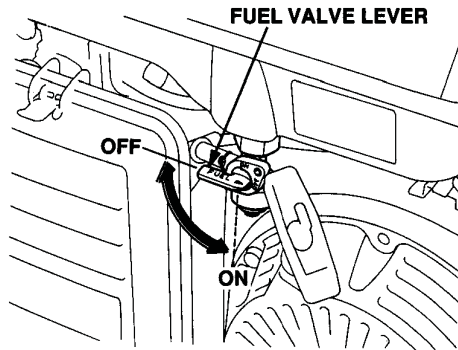

## Choke Rod

The choke is used to provide an enriched fuel mixture when starting a cold engine. It can be opened and closed by operating the choke rod manually. Pull the rod out toward CLOSER to enrich the mixture for cold starting.

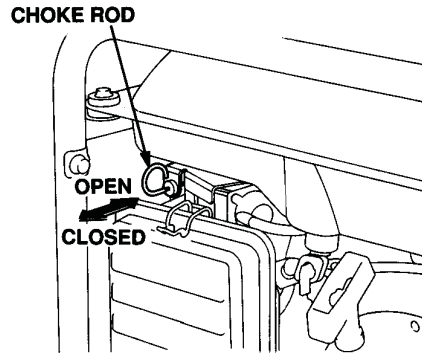

## Circuit Breaker

The circuit breaker will automatically switch **OFF** if there is a short circuit or a significant overload of the generator at the receptacle. If the circuit breaker is switched **OFF** automatically, check that the appliance is working properly and does not exceed the rated load capacity of the circuit before switching the circuit breaker **ON** again.

The circuit breaker may be used to switch the generator power **ON** or **OFF**.

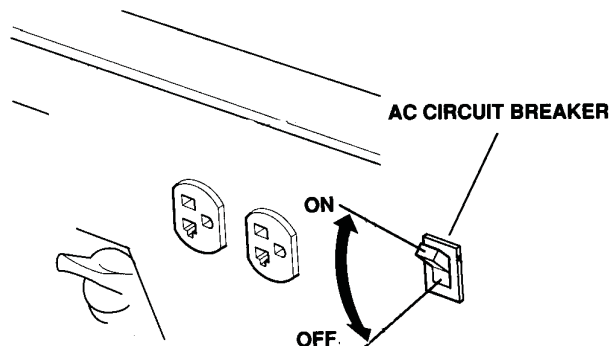

## Oil Alert System

The Oil Alert System is designed to prevent engine damage caused by an insufficient of oil in the crankcase. Before the oil level in the crankcase can fall below a safe limit, the oil alert system will automatically stop the engine (the engine switch will remain in the **ON** position). If the engine stops and will not restart, check the engine oil level before troubleshooting in other areas.

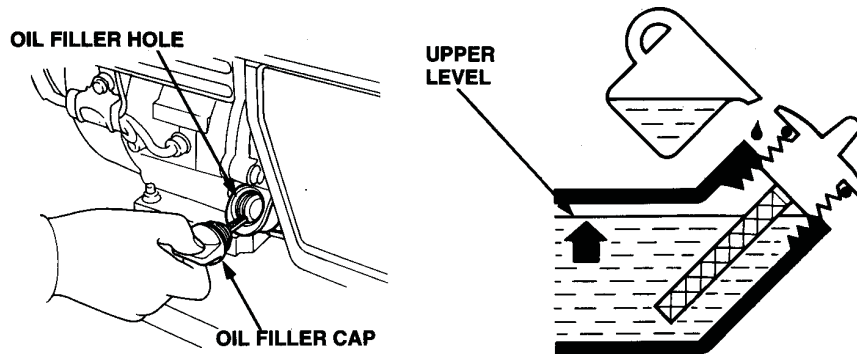

## DC Receptacle

The DC receptacle may **ONLY** be used for charging 12 volt automotive type batteries.

The battery must be connected to the generator DC receptacle with the proper polarity (battery positive to generator positive (+) and battery negative to the generator negative (-)).

### **WARNING:**

Do not start the vehicle while the battery charging cable is connected and the generator is running. The vehicle or the generator may be damaged.

## AC/DC (Weld) Selector Switch

The AC/DC (Weld) selector switch is located on the control panel.

- To avoid accidental arcing, one cable end should be firmly attached to the object to be welded, and the electrode holder at the end of the other cable should be held in the operator's hand. DC voltage is present at the welding terminals at all times, regardless of the position of the AC/DC(WELD) selector.
- Under no circumstances should any type of electrical appliance be plugged into any of the AC receptacles when the selector is in the DC (WELD) position. AC voltage is present at the AC receptacle at all times, regardless of the position of the AC/DC (WELD) selector. However, when this selector is in the DC (WELD) position, the AC voltage is unregulated and fluctuates considerably.

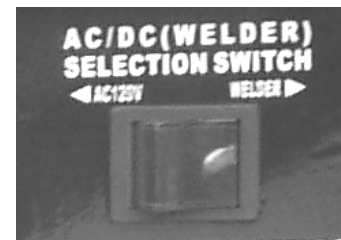

## Welding Cable Terminal

A separate terminal is provided for connection to the welding cable.

**CAUTION:** Failure to use the proper gauge cable may lead to painful burns and/or damage to equipment.

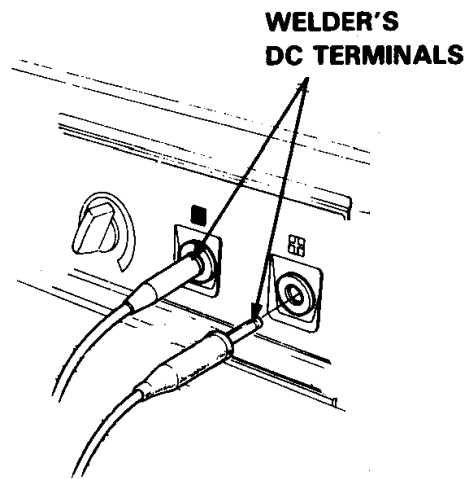

## Welding Current Adjusting System

For best results, it is essential the current be adjusted properly according to the thickness of the materials to be welded and method of welding.

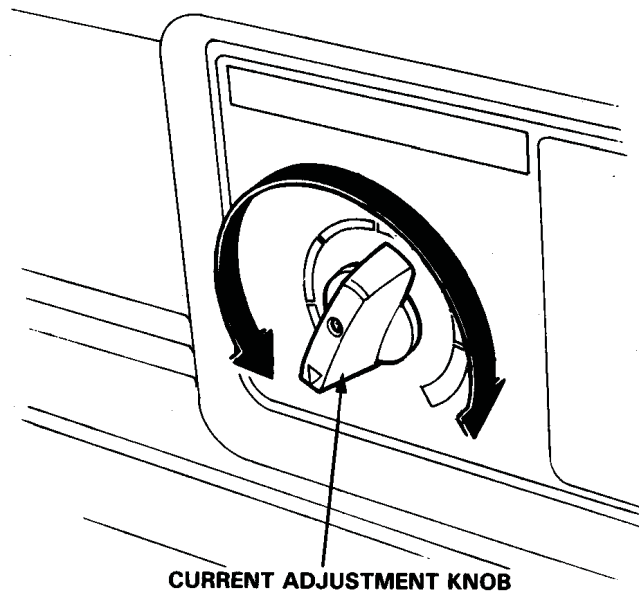

# **GENERATOR/WELDER USE**

## **Connections To A Building Electrical System**

Connections for standby power to a building electrical system must be made by a qualified electrician. The connection must isolate the generator/welder power from utility power, and must comply with all applicable laws and electrical codes. A transfer switch, which isolates generator/welder power from utility power, is available through authorized generator dealers.

Improper connections to a building electrical system can allow electrical current from the generator/welder to back feed into the utility lines. Such back feed may electrocute utility company workers or others who contact the lines during a power outage, and the generator/welder may explode, burn, or cause fires when utility power is restored. Consult the utility company or a qualified electrician.

## **GROUND SYSTEM**

Portable generators/welders have a system ground that connects generator/welder frame components to the ground terminals in the AC output receptacles. The system ground is not connected to the AC neutral wire. If the generator/welder is tested by a receptacle tester, it will not show the same ground circuit condition as for a home receptacle.

## **SPECIAL REQUIREMENTS**

There may be Federal or State Occupational Safety and Health Administration(OSHA) regulations, local codes, or ordinances that apply to the intended use of the generator/welder. Please consult a qualified electrician, electrical inspector, or the local agency having jurisdiction.

- **In some areas, generators/welders are required to be registered with local utility companies.**
- **If the generator/welder is used at a construction site, there may be additional regulations which must be observed.**

## **AC Operation**

1. Start the engine.
2. Switch on the AC circuit breaker.
3. Plug in the appliance.

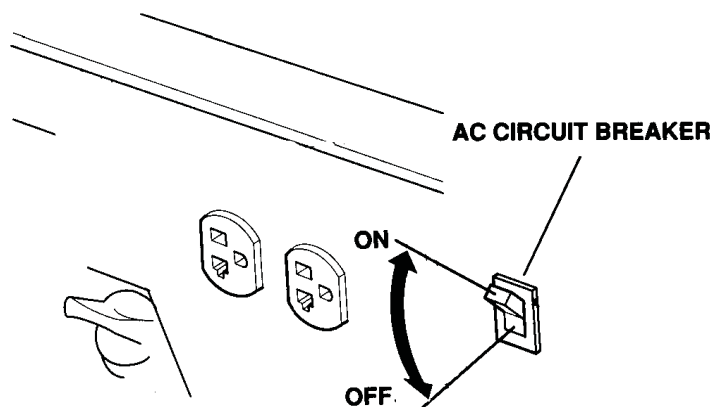

- **Do not connect the generator/welder to a household circuit. This could cause damage to the generator**

or to electrical wiring and appliances in the house.

- For continuous operation, do not exceed the rated load capacity (W-190: 2.0 KVA). In either case, be sure to consider the total power requirements of all connected appliances. Do not exceed the current limit specified for any one receptacle. Substantial overloading will switch off the circuit breaker. Marginal overloading may not switch off the circuit breaker, but it will shorten the service life of the generator/welder.
- If an overloaded circuit causes the AC circuit breaker to switch off, reduce the electrical load on the circuit, and wait a few minutes before resetting the circuit breaker.
- Be sure that all appliances are in good working order before connecting them to the generator. If an appliance begins to operate abnormally, becomes sluggish, or stops suddenly, turn off the circuit breaker and the engine switch immediately. Then disconnect the appliance and examine it for signs of malfunction..
- Most appliance and power tool motors require more than the rated operating current for start-up. To match appliance power needs to generator capability, allow a sufficient generator power reserve to accommodate motor start-up requirements. Appliance and power tool manufacturers usually list rating information near the model number or serial number.

## **Welding**

**WARNING: Welding is potentially a very hazardous activity. It should only be attempted by a trained welder with a thorough knowledge of proper welding techniques and safety procedures. Be sure to read and follow the safety rules of this manual.**

1. Put the Engine Switch in the OFF position. Turn the AC circuit breaker off and remove any plugs from the AC receptacles.

**NOTICE:** *Voltage is present at the welding terminals whenever the engine is running regardless of the position of the AC/DC (WELD) selector.*

2. Connect the welding cables to the welder's DC terminals.

**NOTICE: Failure to use the proper gauge cable may lead to painful burns.**

3. Start the engine and when it has warmed up fully, turn the Auto-Throttle Switch to the AUTO position.
4. Turn the AC/DC (WELD) selector to the DC (WELD) position.
5. Set the current adjustment knob to the proper current level for the job being done.

## Selecting the Correct Welding Current

Measure the thickness of the metal you are welding and then refer to the table below to select the proper electrode size and current setting

PLATE THICKNESS IN INCHES	ELECTRODE DIAMETER IN INCHES	CURRENT SETTING
UP TO 3/16	1/16	50-100
UP TO 1/4	3/32	100-150
ABOVE 1/8	1/8	125-175
ABOVE 1/4	5/32	150-200

Always make a sample weld on a piece of scrap material to be sure you have chosen the correct electrode and current setting.

## Welding Cable Selection

The table below shows the current carrying capacity of various lengths and gauges of standard copper welding cable. Whenever possible, refer to the cable manufacturer's recommendations.

Always allow a considerable safety margin when selecting welding cables. The cable's length and gauge (diameter), along with the material it is made from, all combine to determine how much current it can safely carry.

An undersize welding cable will offer unacceptable high resistance to current flow. This high resistance will shorten the service life of the generator/welder, and can even make the welding cables become hot enough to cause painful burns.

CABLE GAUGE	CABLE DIA	LENGTH IN FEET*		
		0-50 FT.	50-100 FT.	100-250 FT.
CURRENT CAPACITY AMPERES				
1	.644	250	200	170
2	.604	200	195	—

**NOTE: The cable lengths given in the table above are the combined lengths of the negative and positive cables.**

## Welding Duty Cycle

The duty cycle is the percentage of time that the welder can be operated in a given 10 minute period.

For example, at a rated output of 140 amperes, the EW-190's duty cycle is 40%. This means that at 140 amperes, welding can be performed for a total of 5 minutes out of every 10 minute period. The duty cycle is longer at lower operating currents, and shorter at higher currents.

Current	210A	190A	170A	100A	Below 80A
Rate	15%	25%	40%	65%	100%

Do not operate the welder beyond its duty cycle; doing so will decrease the performance and service life of the generator/welder.

## Polarity Selection

The welding terminals are labeled "+" (positive) and "-" (negative). Changing the polarity of the

cables will affect the weld. The correct polarity selection is dependent on the type of electrode you are using and the type of material you are welding; refer to the electrode manufacturer's recommendations for best results.

For straight polarity, attach the electrode cable to the negative terminal, and attach the ground cable to the positive terminal. To reverse polarity, reverse the cables.

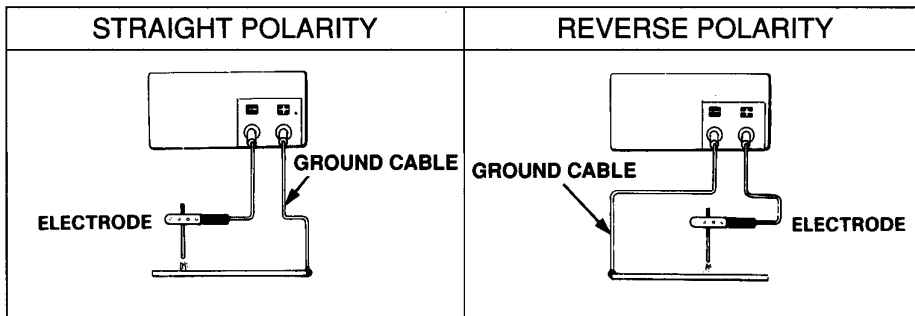

## High Altitude Operation

At high altitude, the standard carburetor air-fuel mixture will be too rich. Performance will decrease, and fuel consumption will increase. A very rich mixture will also foul the spark plug and cause hard starting. Operation at an altitude that differs from that at which this engine was certified, for extended periods of time, may increase emissions. High altitude performance can be improved by specific modifications to the carburetor. If you always operate your generator/welder at altitudes above 5,000 feet (1,500 meters), have an authorized our servicing dealer perform this carburetor modification. This engine, when operated at high altitude with the carburetor modifications for high altitude use, will meet each emission standard throughout its useful life.

Even with carburetor modification, engine horsepower will decrease about 3.5% for each 1000-foot (300-meter) increase in altitude.

The effect of altitude on horsepower will be greater than this if no carburetor modification is made.

**NOTICE:** *When the carburetor has been modified for high altitude operation, the air fuel mixture will be too lean for low altitude use.*

*Operation at altitude below 5000 feet (1,500 meters) with a modified carburetor may cause the engine to overheat and result in serious engine damage. For use at low altitudes, have an authorized our servicing d6aI8r return the carburetor to of original factory specification.*

## PRE-OPERATION CHECK

### Engine oil

**NOTICE:** Engine oil is major affecting engine performance and service life. Non-detergent and 2-stroke engine oils will damage the engine and not recommended.

Check the oil level BEFORE EACH USE with the generator on a level surface with the engine stopped.

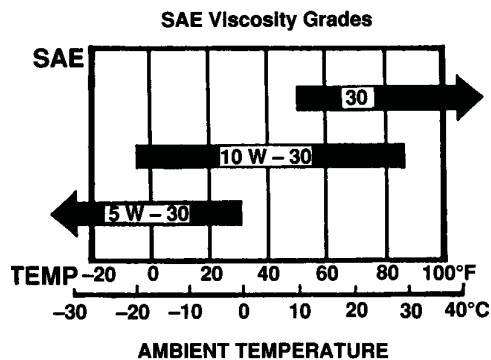

Use 4-stroke motor oil that meets or exceeds the requirements for API service classification SJ. Always check the API SERVICE label on the oil container to be sure it includes the letters SJ'.

SAE 10W-30 is recommended for general, all-temperature use. Other viscosities shown in the chart may be used when the average temperature in your area is within the indicated range.

1. Remove the oil filler cap and wipe the dipstick clean.
2. Check the oil level by inserting the dipstick into the filler neck without screwing it in.
3. If the oil level is low, fill to the top of the oil filler neck with the recommended oil.

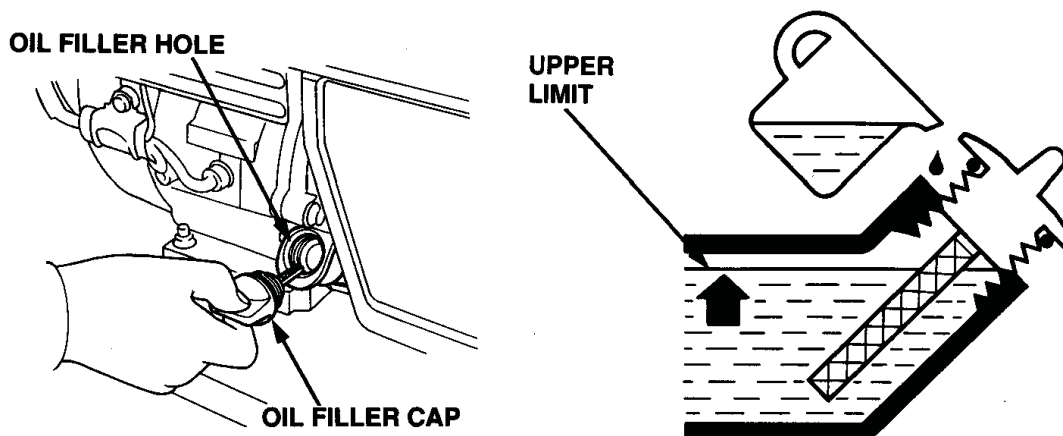

### Fuel Recommendation

1. Check the fuel level gauge.
2. Refill the tank if the fuel level is low. Do not fill above the shoulder of the fuel strainer.

**WARNING:** • Gasoline is extremely flammable and is explosive under certain conditions.

- Refuel in a well-ventilated area with the engine stopped. Do not smoke or allow flames or sparks in the area where the engine is refueled or where gasoline is stored.
- Do not overfill the fuel tank (there should be no fuel in the filler neck). After refueling, make sure the tank cap is closed properly and securely. Be careful not to spill fuel when refueling. Spilled fuel or fuel vapor may ignite. If any fuel is spilled, make sure the area is dry before starting the engine.
- Avoid repeated or prolonged contact with skin or breathing of vapor.
- **KEEP OUT OF REACH OF CHILDREN.**

**Fuel tank capacity:** 7 US gal (25L)

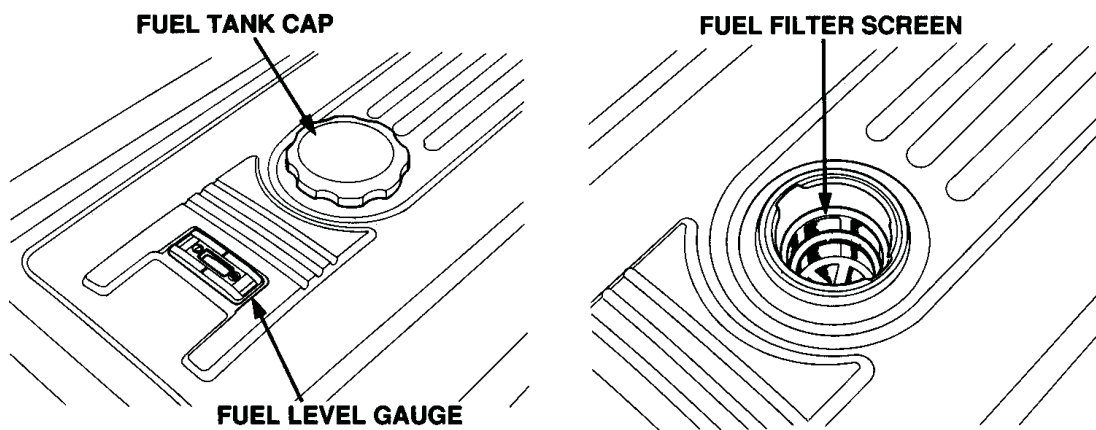

Use gasoline with a pump octane rating of 86 or higher.

This engine is certified to operate on unleaded gasoline.

Unleaded gasoline produces fewer engine and spark plug deposits and extends exhaust system life.

Never use stale or contaminated gasoline or oil/gasoline mixture. Avoid getting dirt or water in the fuel tank.

Occasionally you may hear light "spark knock" or "pinging" (metallic rapping noise) while operating under heavy loads. This is no cause for concern. If spark knock or pinging occurs at a steady engine speed, under normal load, change brands of gasoline.

If spark knock or pinging persists, see an authorized generator dealer.

**NOTICE:** • *Running the engine with persistent spark knock or pinging can cause engine damage.*

- *Running the engine with persistent spark knock or pinging is misuse, and the Distributor's Limited Warranty does not cover parts damaged by misuse.*

## Oxygenated Fuels

Some conventional gasolines are being blended with alcohol or an ether compound. These gasolines are collectively referred to as oxygenated fuels. To meet clean air standards, some areas of the United States and Canada use oxygenated fuels to help reduce emissions.

If you use an oxygenated fuel, be sure it is unleaded and meets the minimum octane rating requirement.

Before using an oxygenated fuel, try to confirm the fuel's contents.

Some states/provinces require this information to be posted on the pump.

The following are the EPA approved percentages of oxygenates

**ETHANOL**—(ethyl or grain alcohol) 10% by volume.

You may use gasoline containing up to 10% ethanol by volume. Gasoline containing ethanol may be marketed under the name Gasohol.

**MTBE** — (methyl tertiary butyl ether) 15% by volume

You may use gasoline containing up to 15% MTBE by volume.

**METHANOL** — (methyl or wood alcohol) 5% by volume

You may use gasoline containing up to 5% methanol by volume as long as it also contains co solvents and corrosion inhibitors to protect the fuel system. Gasoline containing more than 5% methanol by volume may cause starting and/or performance problems. It may also damage metal, rubber, and plastic parts of your fuel system.

If you notice any undesirable operating symptoms, try another service station or switch to another brand of gasoline.

Fuel system damage or performance problems resulting from the use of an oxygenated fuel containing more than the percentages of oxygenated mentioned above are not covered under warranty.

## **STARTING THE ENGINE/STOPPING THE ENGINE**

### **Starting the Engine**

1. Make sure that the AC circuit breaker is in the OFF position, and that there are no welding cables attached to the DC terminals. The generator may be hard to start if a load is connected.
2. Turn the fuel valve lever to the ON position.
3. Pull the choke rod to the CLOSE position.
4. Make sure the auto-throttle switch is in the OFF position, or more time will be required for warm-up.
5. Move the engine switch to the ON position.
6. Pull the starter grip lightly until resistance is felt, then pull briskly.

**NOTICE:** *Do not allow the starter grip to snap back against the engine. Return it gently to prevent damage to the starter or housing.*

7. Push the choke rod to the OPEN position as the engine warms up.
8. If you wish to use the auto-throttle system, turn the auto-throttle switch to the AUTO position after the engine has warmed up for 2 or 3 minutes.

### **Stopping the Engine**

#### **In an emergency:**

1. To stop the engine in an emergency, move the engine switch to the OFF position.

#### **In normal use:**

1. Turn off any AC electrical appliance.
2. Move the engine switch to the OFF position.
3. Turn the fuel valve lever to the OFF position.

# **MAINTENANCE**

---

## **The Importance of Maintenance**

Good maintenance is essential for safe, economical, and trouble-free operation. It will also help reduce air pollution.

**WARNING: Improper maintenance, or failure to correct a problem before operation, can cause a malfunction in which you can be seriously hurt or killed.**

**Always follow the inspection and maintenance recommendations and schedules in this owner's manual.**

To help you properly care for your generator, the following pages include a maintenance schedule, routine inspection procedures, and simple maintenance procedures using basic hand tools. Other service tasks that are more difficult, or require special tools, are best handled by professionals and are normally performed by a our technician or other qualified mechanic.

The maintenance schedule applies to normal operating conditions. If you operate your generator under severe conditions, such as sustained high-load or high-temperature operation, or use in unusually wet or dusty conditions, consult your servicing dealer for recommendations applicable to your individual needs and use.

**Maintenance, replacement, or repair of the emission control devices and systems may be performed by any engine repair establishment or individual, using parts that are "certified" to EPA standards.**

## **Maintenance Safety**

Some of the most important safety precautions follow. However, we cannot warn you of every conceivable hazard that can arise in performing maintenance. Only you can decide whether or not you should perform a given task.

**Failure to properly follow maintenance instructions and precautions can cause you to be seriously hurt or killed.**

**Always follow the procedures and precautions in the owner's manual.**

### **Safety precautions.**

- Make sure the engine is off before you begin any maintenance or repairs. This will eliminate several potential hazards:
  - **Carbon monoxide poisoning from engine exhaust.**

Be sure there is adequate ventilation whenever you operate the engine.
  - **Burns from hot parts.**

Let the engine and exhaust system cool before touching.
  - **Injury from moving parts.**

Do not run the engine unless instructed to do so.
- Read the instructions before you begin, and make sure you have the tools and skills required.

- To reduce the possibility of fire or explosion, be careful when working around gasoline. Use only a nonflammable solvent, not gasoline, to clean parts. Keep cigarettes, sparks, and flames away from all fuel-related parts.

Remember that your servicing dealer knows your generator best and is fully equipped to maintain and repair it.

To ensure the best quality and reliability, use only new, genuine parts or their equivalents for repair or replacement.

## **Emission Control System Information**

### **Source of Emissions**

The combustion process produces carbon monoxide, oxides of nitrogen, and hydrocarbons. Control of hydrocarbons and oxides of nitrogen is very important because, under certain conditions, they react to form photochemical smog when subjected to sunlight. Carbon monoxide does not react in the same way, but it is toxic.

Our Utilizes lean carburetor settings and other systems to reduce the emissions of carbon monoxide, oxides of nitrogen, and hydrocarbons.

### **The U.S. and California Clean Air Acts**

EPA and California regulations require all manufacturers to furnish written instructions describing the operation and maintenance of emission control systems.

The following instructions and procedures must be followed in order to keep the emissions from your engine within the emission standards.

### **Tampering and Altering**

Tampering with or altering the emission control system may increase emissions beyond the legal limit. Among those acts that constitute tampering are:

- Removal or alteration of any part of the intake, fuel, or exhaust systems.
- Altering or defeating the governor linkage or speed-adjusting mechanism to cause the engine to operate outside its design parameters.

### **Problems That May Affect Emissions**

If you are aware of any of the following symptoms, have your engine inspected and repaired by your servicing dealer.

- Hard starting or stalling after starting.
- Rough idle.
- Misfiring or backfiring under load.
- Afterburning (backfiring).
- Black exhaust smoke or high fuel consumption.

### **Replacement Parts**

The emission control systems on your our engine were designed, built, and certified to conform

with EPA and California emission regulations. We recommend the use of genuine our parts whenever you have maintenance done. These original-design replacement parts are manufactured to the same standards as the original parts, so you can be confident of their performance. The use of replacement parts that are not of the original design and quality may impair the effectiveness of your emission control system.

A manufacturer of an aftermarket part assumes the responsibility that the part will not adversely affect emission performance. The manufacturer or rebuild of the part must certify that use of the part will not result in a failure of the engine to comply with emission regulations.

## Maintenance

Follow the maintenance schedule on page 35. Remember that this schedule is based on the assumption that your machine will be used for its designed purpose. Sustained high-load or high-temperature operation, or use in unusually wet or dusty conditions, will require more frequent service.

## Air Index

An Air Index Information hang tag/label is applied to engines certified to an emission durability time period in accordance with the requirements of the California Air Resources Board.

The bar graph is intended to provide you, our customer, the ability to compare the emissions performance of available engines. The lower the Air Index, the less pollution.

The durability description is intended to provide you with information relating to the engine's emission durability period. The descriptive term indicates the useful-life period for the engine's emission control system. See your *Emission Control Warranty* for additional information.

Descriptive Term	Applicable to Emission Durability Period
Moderate	50 hours (0-65 cc) 125 hours (greater than 65 cc)
Intermediate	125 hours (0-65 cc) 250hours (greater than 65 cc)
Extended	300hours (0-65 cc) 500 hours (greater than 65 cc)

The Air Index Information hang tag must remain on the generator/welder until it is sold. Remove the hang tag before operating the generator/welder.

## Maintenance Schedule

REGULAR SERVICE PERIOD (3)		Each use	First month or 20 Hrs	Every 3 month or 50 Hrs	Every 6 month or 100 Hrs	Every year or 300 Hrs
• Engine oil level	Check	○				
	Change		○		○	
• Air filter	Check	○				
	Clean			○(1)		
• Sediment cup	Clean				○	
• Spark plug	Check-adjust				○	
	Replace					○
Spark arrester	Clean				○	
• Idle speed	Check-adjust					○(2)
• Valve clearance	Check-adjust					○(2)
• Combustion chamber	Clean					After every 500 Hrs (2)
• Fuel tank	Clean	Every years (2)				
• Fuel filter	Check				○	
	Replace					○(2)
• Fuel tube	Check	Every 2 years (Replace if necessary) (2)				

**NOTE:** • Emission related items.

(1) Service more frequently when used in dusty areas.

(2) These items should be serviced by your servicing dealer, unless the owner has the proper tools and is mechanically proficient. See the Our Shop Manual.

(3) For professional commercial use, log hours of operation to determine proper maintenance intervals.

## Engine Oil Change

Drain the oil while the engine is warm to assure complete and rapid draining.

1. Remove the drain plug and sealing washer, remove the oil filler cap, and drain the oil.
2. Install the drain plug and sealing washer. Tighten the plug securely.
- 3 Refill with the recommended oil and check the level.

**Oil capacity:** 1 .16 US qt (1.1L 0.97 imp qt)

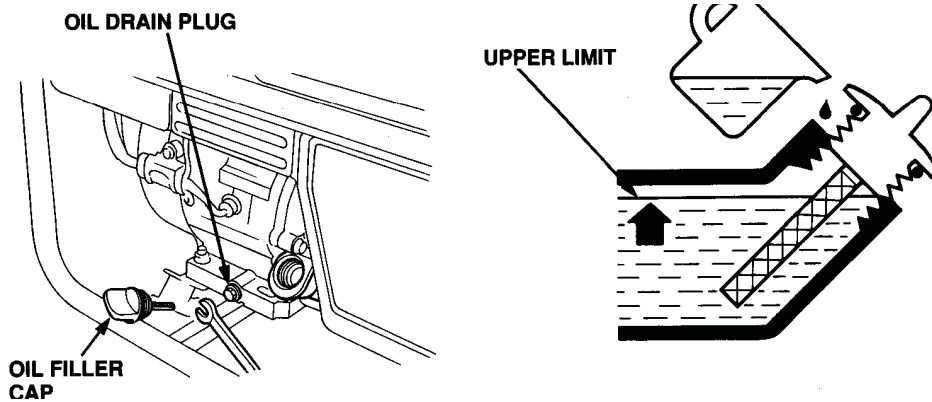

Wash your hands with soap and water after handling used oil.

Please dispose of used motor oil in a manner that is compatible with the environment. We suggest you take it in a sealed container to your local service station or recycling center for reclamation. Do not throw it in the trash or pour it on the ground, or down a drain.

## Air Cleaner Service

A dirty air cleaner will restrict air flow to the carburetor. To prevent carburetor malfunction, service the air cleaner regularly. Service more frequently when operating the generator/welder in extremely dusty areas.

**NOTICE:** *Never run the generator/welder without the air cleaner. Rapid engine wear will result.*

1. Unsnap the air cleaner cover clips, remove the air cleaner cover, and remove the element.
2. Wash the element in a solution of household detergent and warm water, then rinse thoroughly, or wash in nonflammable or high flash point solvent. Allow the element to dry thoroughly.
3. Soak the element in clean engine oil and squeeze out the excess oil. The engine will smoke during initial start-up if too much oil is left in the element.
4. Reinstall the air cleaner element and the cover.

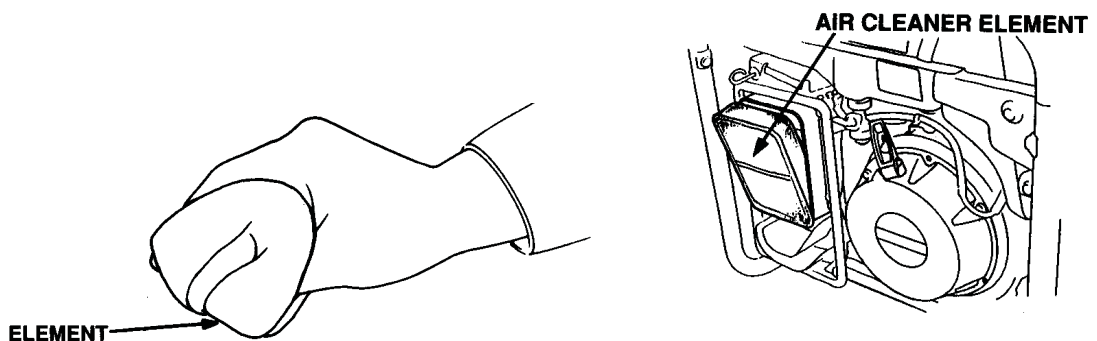
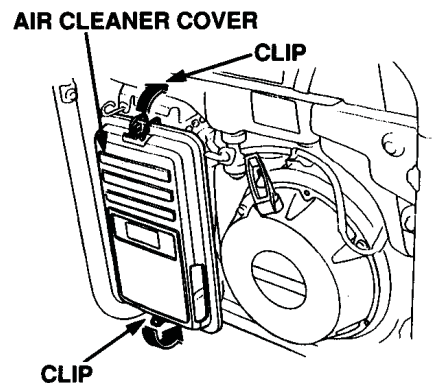

## Fuel Sediment Cup Cleaning

The sediment cup prevents dirt or water which may be in the fuel tank from entering the carburetor. If the engine has not been run for a long time, the sediment cup should be cleaned.

1. Turn the fuel valve lever to the OFF position. Remove the sediment Cup, O-ring, and filter.
2. Clean the sediment cup, O-ring, and filter in nonflammable or high flashpoint solvent.
3. Reinstall the filter, O-ring, and sediment cup.
4. Turn the fuel valve lever ON and check for leaks.

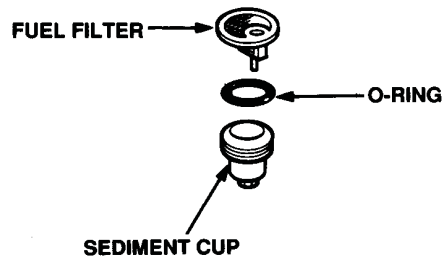
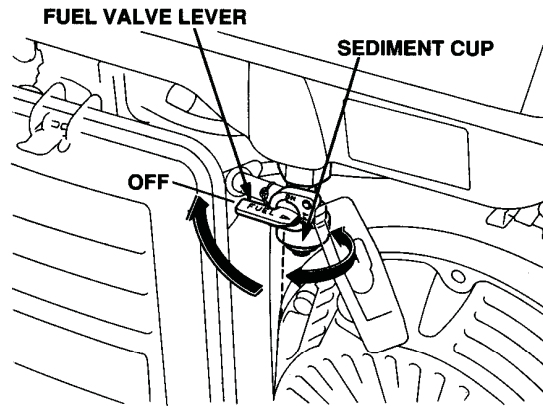

## Spark Plug Service

In order to service the spark plug, you will need a spark plug wrench (commercially available).

**Recommended spark plugs:** BPR5ES (NGK)

W16EPR-U (DENSO), F7RTC

To ensure proper engine operation, the spark plug must be properly gapped and free of deposits.

If the engine has been running, the muffler will be very hot. Be careful not to touch the muffler.

1. Remove the spark plug cap.
2. Clean any dirt from around the spark plug base.
3. Use a spark plug wrench to remove the spark plug.

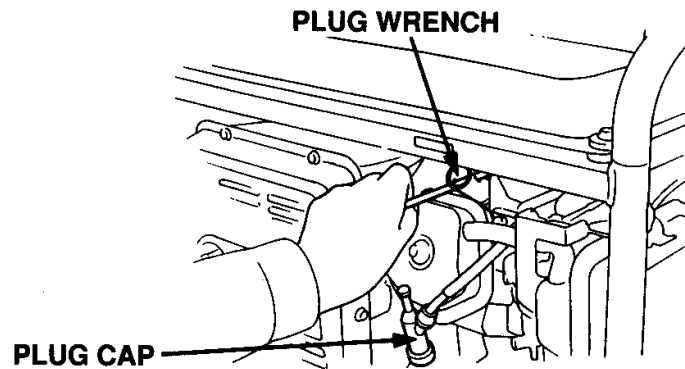

4. Visually inspect the spark plug. Discard it if the insulator is cracked or chipped. Clean the spark plug with a wire brush if it is to be reused.
5. Measure the plug gap with a feeler gauge.

Correct as necessary by carefully bending the side electrode.

**The gap should be:** 0.028-0.031 in (0.70--0.80 mm)

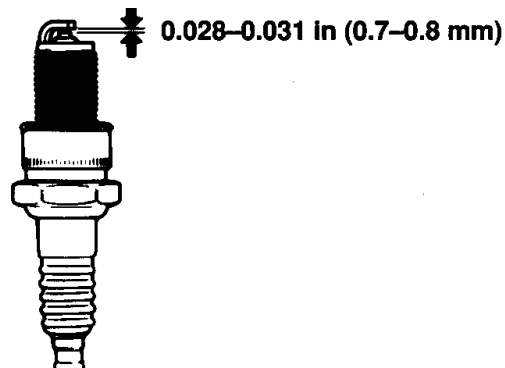

7. Check that the spark plug washer is in good condition, and thread the sparkplug in by hand to prevent cross-threading.
8. After the spark plug is seated, tighten with a spark plug wrench to compress the washer.
  - If installing a new spark plug, tighten 1/2 turn after the spark plug seats to compress the washer.
  - If reinstalling a used spark plug, tighten 1/8-1/4 turn after the spark plug seats to compress the washer.

**NOTICE:** *The Spark plug must be securely tightened. An improperly tightened Spark plug can become very hot and could damage the engine. Never use spark plugs which have an improper heat range. Use only the recommended Spark plugs or equivalent.*

## **TRANSPORTING STORAGE**

When transporting the generator/welder, turn the engine switch and the fuel valve OFF and keep the generator/welder level to prevent fuel spillage. Fuel vapor or spilled fuel may ignite.

**WARNING: Contact with a hot engine or exhaust system can cause serious burns or fires. Let the engine cool before transporting or storing the generator/welder.**

Take care not to drop or strike the generator/welder when transporting. Do not place heavy objects on the generator/welder.

Before storing the unit for an extended period:

1. Be sure the storage area is free of excessive humidity and dust.
2. Service according to the table below:

<b>STORAGE TIME</b>	<b>RECOMMENDED SERVICE PROCEDURE TO PREVENT HARD STARTING</b>
Less than 1 month	No preparation required
1 to 2 months	Fill with fresh gasoline and add gasoline stabilizer*.
2 months to 1 year	Fill with fresh gasoline and add gasoline stabilizer*. Drain the carburetor float bowl. (page 42). Drain the fuel sediment cup. (page 38).
1 year or more	Fill with fresh gasoline and add gasoline stabilizer*. Drain the carburetor float bowl. (page 42). Drain the fuel sediment cup. (page 38) Remove the spark plug. Put a tablespoon of engine oil into the cylinder. Turn the engine slowly with the pull rope to distribute the oil. Reinstall the spark plug. Change the engine oil. (page 36). After removal from storage, drain the stored gasoline into a suitable container, and fill with fresh gasoline before starting.
* Use gasoline stabilizer that are formulated to extend storage life. Contact your authorized our generator dealer for conditioner recommendation	

### **Storage Procedure**

1. Drain the carburetor by loosening the drain screw. Drain the gasoline into a suitable container.

**WARNING: Gasoline is extremely flammable and is explosive under certain conditions. Perform this task in a well ventilated area with the engine stopped. Do not smoke or allow flames or sparks in the area during this procedure.**

### DRAIN SCREW

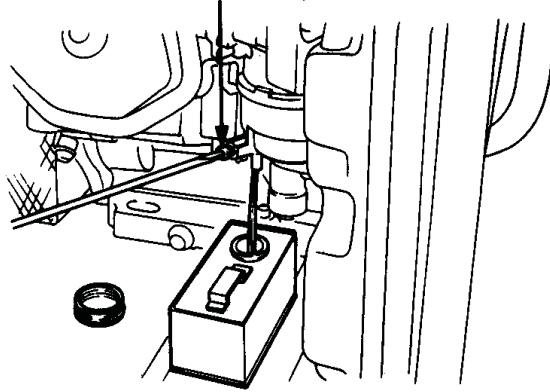

2. Change the engine oil.
3. Remove the spark plug, and pour about a tablespoon of clean engine oil into the cylinder. Crank the engine several revolutions to distribute the oil, then reinstall the spark plug.
4. Slowly pull the starter grip until resistance is felt. At this point, the piston is coming up on its compression stroke and both the intake and exhaust valves are closed. Storing the engine in this position will help to protect it from internal corrosion.

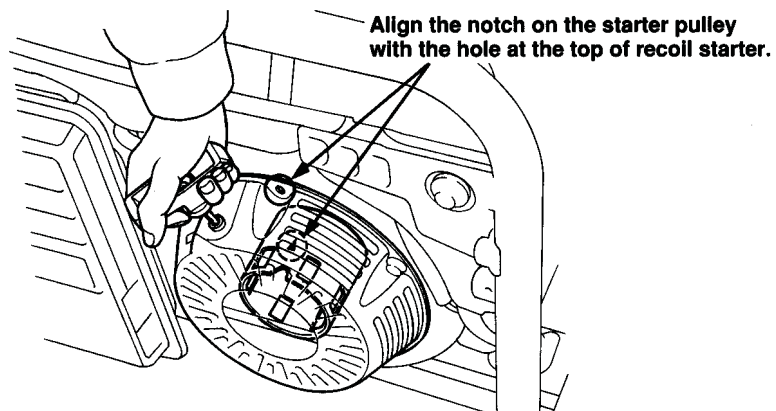

# WIRING DIAGRAM

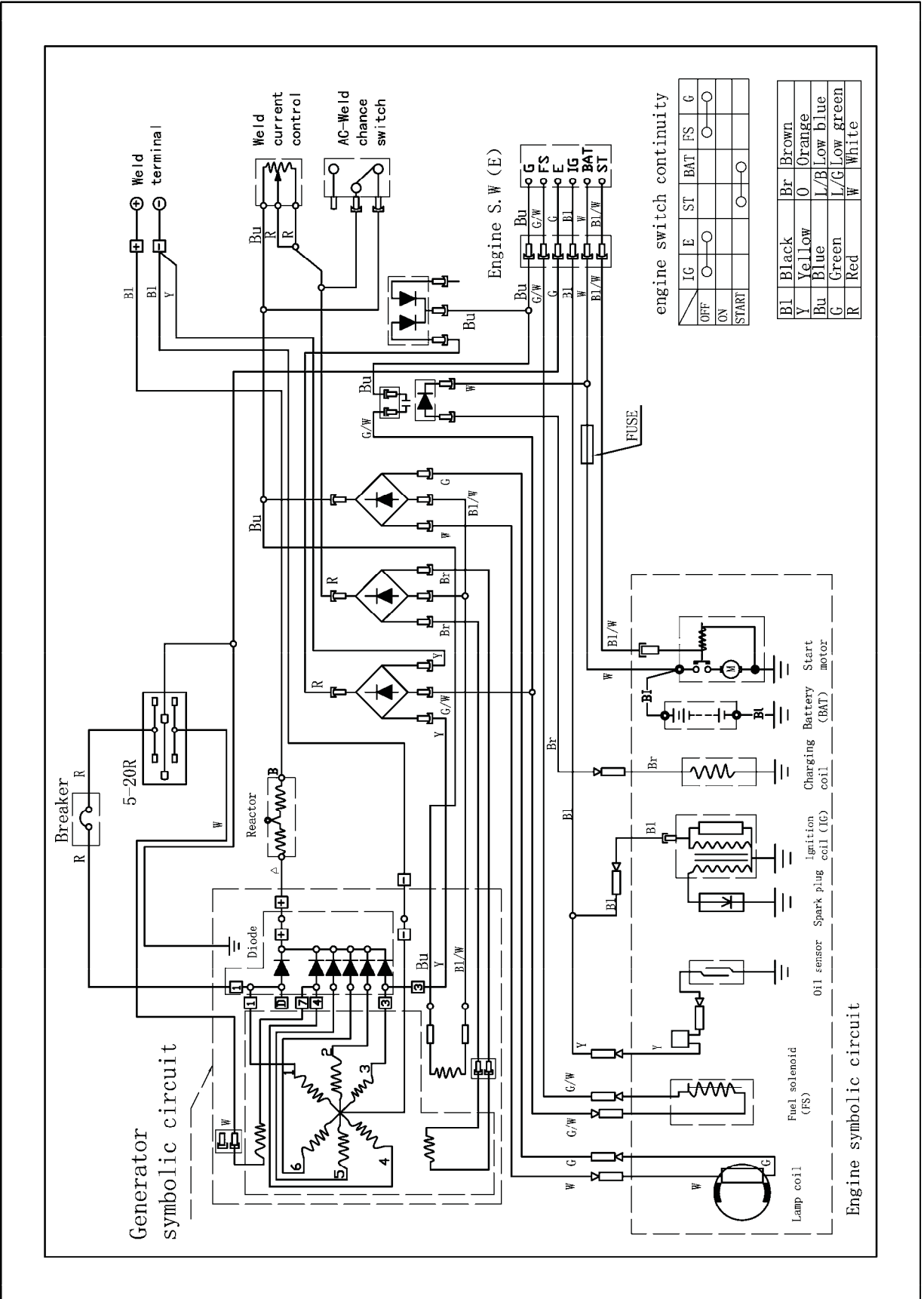

## SPECIFICATION

---

### Dimensions

Model	PD210E
Length×Width×Height	29×22×22 in (712×540×540mm)
Dry weight	217.8 lb (98kg)

### Engine

Model	190FE
Engine type	4-stroke, overhead valve, single cylinder
Displacement (Bore×Stroke)	25.6cu in (419cc) 3.54×2.6 in (90×66mm)
Compression ratio	8.0:1
Engine speed	3,600 rpm
Cooling system	Forced air
Ignition system	Transistorized magneto
Oil capacity	1.16 US qt (1.1L, 0.97 imp qt)
Fuel tank capacity	6.6 US gal (25L)
Spark plug	BPR5ES (NGK), W16EPR-U (DENSO), F7RTC

### Generator

DC (WELDING) Output	Rated current	160A
	Rated voltage	28.5V
	Welding current	50-210A
	Duty cycle	60% -160A
	Electrode diameter	3/32, 1/8, 5/32 in (2.6-4.0mm)
AC Output	Rated voltage	120V
	Rated frequency	60Hz
	Rated amperage	29A
	Rated output	3500W
	Max. output	4000W

### Tune-up Specifications

ITEM	SPECIFICATION	MAINTENANCE
Spark plug gap	0.028-0.031 in (0.70-0.80mm)	Refer to page: 23
Valve clearance	IN: 0.15 ± 0.02mm (cold) EX: 0.20 ± 0.02 mm (cold)	See your authorized our dealer
Other specifications	No other adjustments needed	

**NOTE:** Specifications may vary according to types, and are subject to change without notice.

# WHEEL KIT

## Handle/Wheel support and wheel kit.

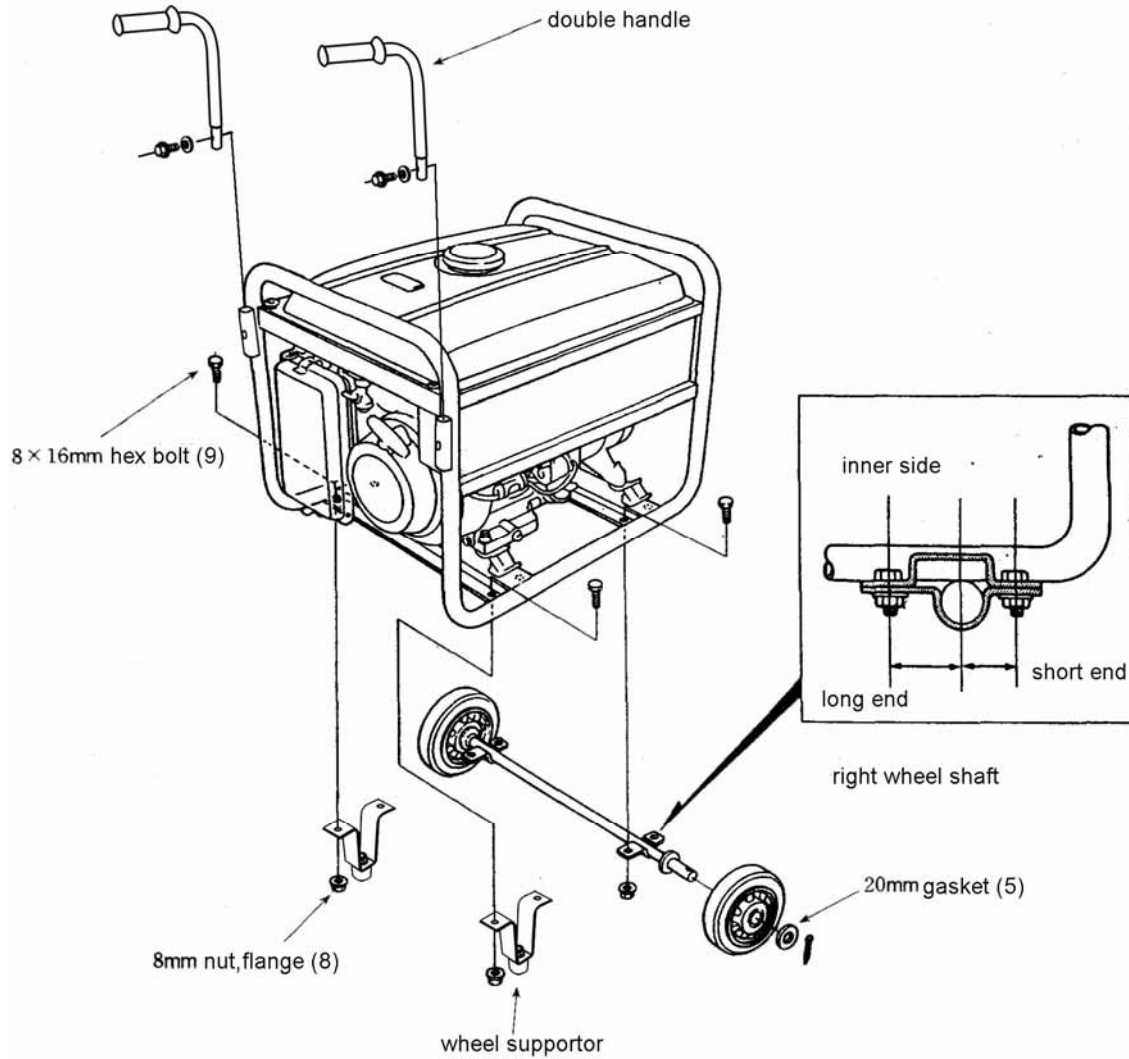

# EXPLODED VIEW AND PARTS LIST

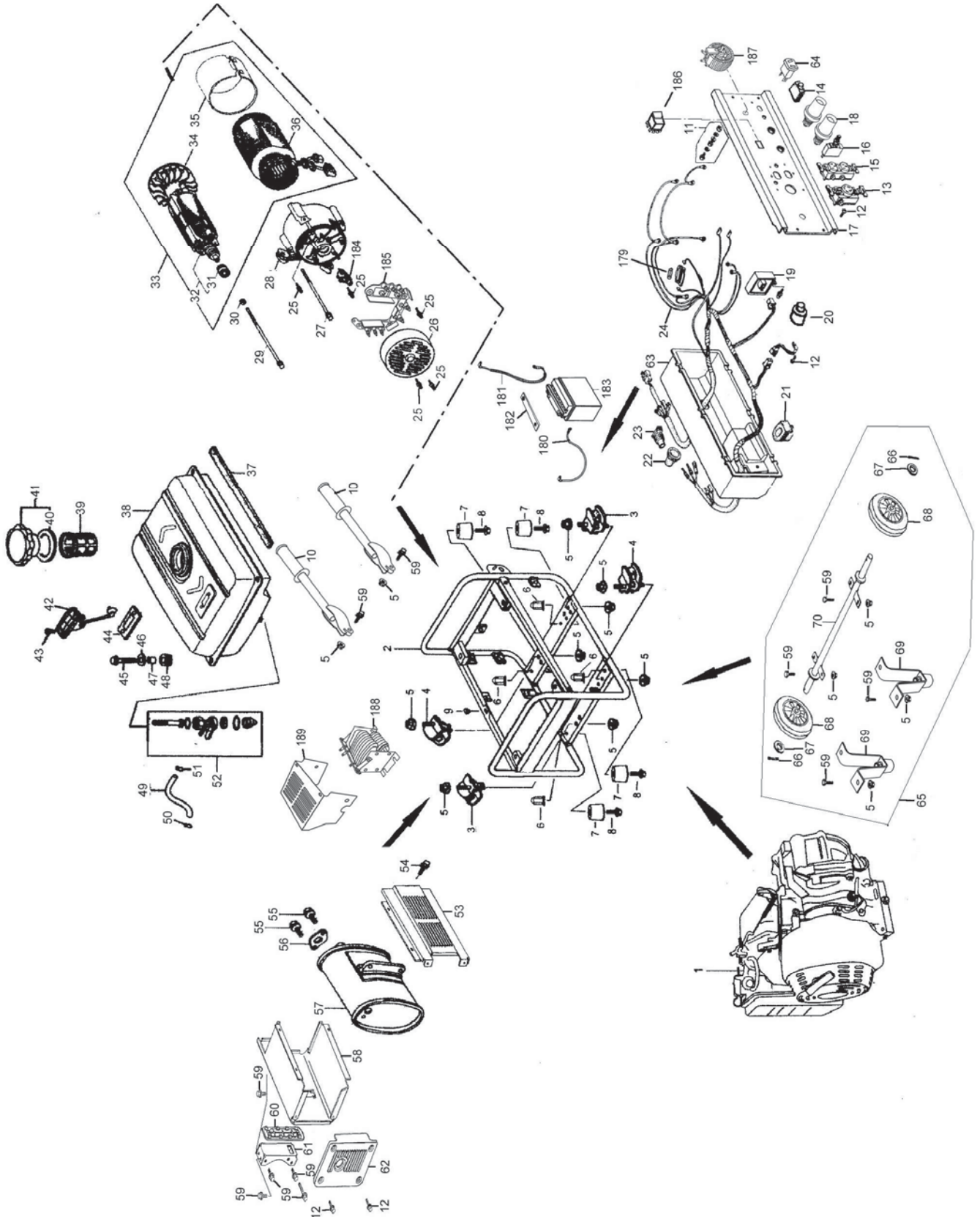

Item	Part	Qty	Description	Item	Part	Qty	Description
1		1	Gasoline engine	42	14400	1	Fuel sensor
2	15100	1	Frame comp	43	GB 819-95	2	Screw M5×10
3	15002	2	Bottom rubber A	44	14410	1	Casket fuel tank
4	15003	2	Bottom rubber B	45	GB5787-86	5	Flange bolt M6×25
5	GB6177-86	16	Flange nut M8	46	14022	4	Washer
6	GB802-88	4	Flange nut M6	47	14005	4	Collar
7	41350	4	Cushion, frame	48	14001	4	Cushion
8	GB5787-86	12	Bolt M6×12	49	14004	1	Outlet pipe $\phi$ 4.5×165
9	15001	2	Rubber pad, frame	50	14006	2	Tube clip
10	15201	2	Hand push	51	14003	1	Rubber, fuel tube
11	11010	1	Earth terminal set	52	14100	1	Fuel cock
12	GB5787-86	8	Flange bolt M6×12	53	13001	1	Protector comp muffler
13	11070	1	Receptacle (30A)	54	GB5787-86	4	Flange bolt M6×14
14	11195	1	DC protector (10A)	55	GB5787-86	2	Flange bolt M8×32
15	11072	1	Receptacle (20A)	56	13010	1	Muffler stay
16	11120	2	Circuit Breaker (29A)	57	13020	1	Muffler
17	11090	1	Control panel	58	13002	1	Protector muffler inner
18	11130	2	Weld terminal	59	GB5789-86	10	Flange bolt M8×16
19	11050	4	Diode assembly	60	13004	1	Seal protector muffler
20	11082	1	Engine switch	61	13005	1	Muffler, stay comp
21	11040	1	Boot, switch wire	62	13003	1	Protector muffler side
22	11030	1	Boot, main wire harness	63	11091	1	Control panel case
23	11010	1	Boot, AC output wire	64	11101	2	DC receptacle
24	11060	1	Wire harness assembly	65	21000	1	Wheel assembly
25	GB5787-86	9	Flange bolt M5×16	66	21050	2	Pin.
26	16004	1	Generator end cover	67	GB97.1-85	2	Washer $\phi$ 20
27	GB5789-86	4	Flange bolt M6×190	68	21040	2	Wheel comp
28	16003	1	Support stand	69	21020	2	Bracket
29	GB5789-86	1	Bolt M10×1.25×275	70	21010	1	Well shaft
30	GB9701-85	1	Plain washer $\phi$ 10	179	11096	1	Fuse(5A)
31	GB276-89	1	Bearing 6207-2RS	180	22001	1	Positive wire of battery
32	16200	1	Rotor comp	181	22002	1	Negative wire of battery
33	16000	1	Stator & Rotor assembly	182	22005	1	Battery cover
34	16005	1	Generator fan	183	22010	1	Battery
35	16101	1	Stator cover	184	11070	1	Brush assembly
36	16100	1	Stator assembly	185	11090	1	Diode assembly
37	14201	1	Stripe, fuel tank	186	10076	1	AC-Weld change switch
38	14200	1	Fuel tank	187	11085	1	Current contrl
39	14302	1	Fuel filter	188	11087	1	Reactor
40	14303	1	Packing ring	189	10088	1	Reactor cover
41	14300	1	Fuel filler cap comp				

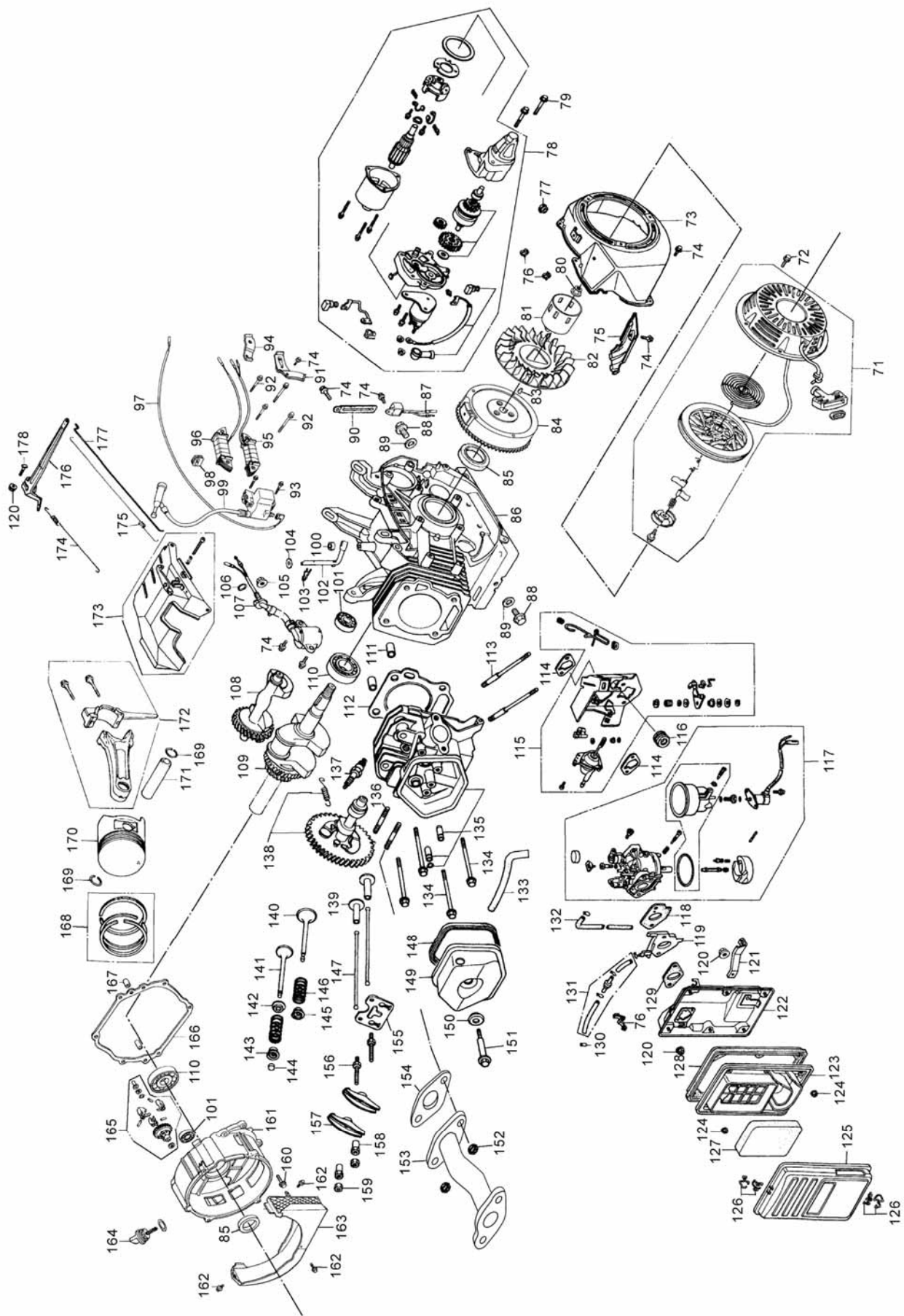

Item	Part	Qty	Description	Item	Part	Qty	Description
71	21100	1	Starter comp, recoil	115	22000	1	Stay assembly choke
72	GB5787-86	3	Flange bolt M6×8	116	12012	1	Grommet fender
73	12310	1	Fan, cover comp	117	23000	1	Carburetor assembly
74	GB5787-86	13	Flange bolt M6×12	118	23002	1	Packing, carburetor
75	19003	1	Shroud comp	119	23001	1	Insulator, carburetor
76	12302	3	Clip. Wire darkness	120	GB6177-86	4	Flange nut M6
77	12302	1	Grommet drain hole	121	12006	1	Stay, air cleaner
78	21000	1	Start motor	122	12005	1	Case comp, air cleaner
79	GB5789-86	2	Flange bolt M8×35	123	12004	1	Separator, air cleaner
80	GB6177-86	1	Flange nut M16	124	GB6177-86	6	Flange nut M5
81	19005	1	Pulley, starter	125	12007	1	Cover comp, air cleaner
82	19001	1	Fan, cooling	126	12008	2	Clip, air cleaner ware
83	GB/T 99-88	1	Key	127	12003	1	Element, air cleaner
84	81200	1	Flywheel comp	128	12010	1	Seal, air cleaner
85	12215	2	Oil seal, 35×52×8	129	23003	1	Packing, insulator
86	12200	1	Crank case assembly	130	23011	4	Clip, tube
87	87500	1	Amplifier	131	23006	1	Valve, dashpot check assy
88	12203	2	Bolt, drain lug	132	91009	1	Tube, fuel φ45×165
89	12217	2	Washer, drain lug	133	12001	1	Tube, breather
90	87601	1	Clip, wire	134	GB5789-86	4	Flange bolt M10×80
91	21012	1	Protect board A	135	11250	1	Head comp, cylinder
92	GB5789-86	4	Flange bolt M6×30	136	11217	2	Bolt head, M8×34
93	GB5789-86	2	Flange bolt M6×25	137	11202	1	Plug, spark
94	21011	1	Protect board B	138	15100	1	Camshaft assembly
95	21000	1	Coil assembly excitation	139	15002	2	Lifter, valve
96	22000	1	Coil assembly charge	140	11208	1	Valve, IN.
97	81102	1	Cord stop switch	141	11209	1	Valve, EX.
98	81103	1	Grommet cord	142	11216	1	Seat, valve spring
99	81100	1	Coil assembly ignition	143	11212	1	Retainer, EX. Valve spring
100	12216		Oil seal, 8×14×5	144	11213	1	Rotator, valve
101	GB/T276-94	2	Radial ball bearing (6202)	145	11211	1	Retainer, IN. Valve spring
102	12208	1	Shaft, governor arm	146	11206	2	Spring, valve
103	12212	1	Pin, lock, 10mm	147	15001	2	Rod, push
104	12209	1	Washer, 8.2×17×0.8	148	11241	1	Exhaust piper
105	GB6177-86	1	Flange nut M10	149	11240	1	Cover comp, head
106	12221	1	O-ring, 14mm	150	11243	1	Washer comp head cover
107	12200	1	Switch assembly oil level	151	11242	1	Bolt, head cover
108	13200	1	Weight, balancer	152	GB6175-86	2	Nut M8
109	13000	1	Crankshaft comp	153	13200	1	Pipe comp EX.
110	GB/T276-94	2	Radial ball bearing (6207)	154	13202	1	Casket (B) EX. Pipe
111	12220	2	Pin, dowel, 12×20	155	11215	1	Plate, push rod guide
112	11219	1	Casket, cylinder head	156	11214	2	Bolt, pivot
113	11218	2	Bolt head, 8×106	157	11205	2	Arm, valve rocker
114	23008	2	Packing, air cleaner	158	11204	2	Nut, Arm, valve rocker

