

**PDZ2045**  
**Single Direction**  
**Vibratory Asphalt Plates**  
**Owner's Manual**

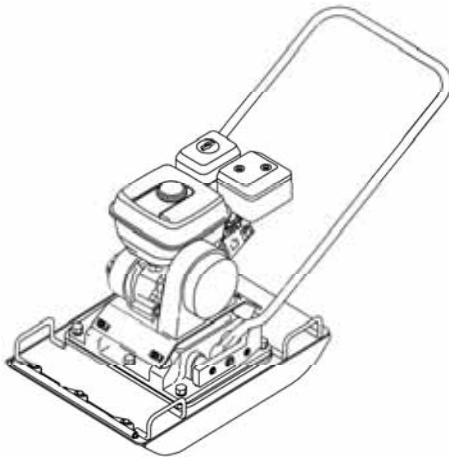

**SAVE THIS MANUAL FOR FUTURE REFERENCE**

This manual provides information regarding the operation and maintenance of these products. We have made every effort to ensure the accuracy of the information in this manual. We reserve the right to change this product at any time without prior notice.

Please keep this manual available to all users during the entire life of the Vibratory.

## TABLE OF CONTENTS

|  |    |
|--|----|
| 1. Foreword .....  | 3  |
| 2. Safety Information .....                                    | 4  |
| 2.1 Laws Pertaining to Spark Arresters .....                   | 4  |
| 2.2 Operating Safety .....                                     | 5  |
| 2.3 Operator Safety while using Internal Combustion Engines .. | 6  |
| 2.4 Service Safety .....                                       | 7  |
| 2.5 Label Locations .....                                      | 8  |
| 2.6 Warning and Informational Labels .....                     | 9  |
| 2.7 Operating Labels .....                                     | 11 |
| 3. Technical Data .....  | 13 |
| 3.1 Engine Data .....  | 13 |
| 3.2 Machine Data .....   | 14 |
| 3.3 Sound and Vibration Specifications .....                   | 14 |
| 3.4 Dimensions .....   | 15 |
| 4. Operation .....   | 16 |
| 4.1 Recommended Fuel .....                                     | 16 |
| 4.2 Before Starting .....                                      | 16 |
| 4.3 To Start .....   | 16 |
| 4.4 To Stop .....  | 17 |
| 4.5 Application .....  | 17 |
| 4.6 Operation .....  | 18 |
| 5. Maintenance .....   | 19 |
| 5.1 Periodic Maintenance Schedule .....                        | 19 |

|                                  |    |
|----------------------------------|----|
| 5.2 Cleaning Plate .....         | 19 |
| 5.3 Drive Belt .....             | 20 |
| 5.4 Spark Plug .....             | 21 |
| 5.5 Engine Oil .....             | 22 |
| 5.6 Air Cleaner .....            | 23 |
| 5.7 Cleaning Sediment Cup .....  | 24 |
| 5.8 Adjusting Engine Speed ..... | 24 |
| 5.9 Carburetor Adjustment .....  | 25 |
| 5.10 Troubleshooting .....       | 26 |
| 5.11 Storage .....               | 26 |
| 5.12 Lifting Machine .....       | 27 |
| 5.13 Transporting Machine .....  | 28 |



**WARNING:** Engine exhaust, some of its constituents, and certain vehicle components contain or emit chemicals known to the State of California to cause cancer and birth defects or other reproductive harm.

## 1. Foreword

This manual provides information and procedures to safely operate and maintain the model. For your own safety and protection from injury, carefully read, understand and observe the safety instructions described in this manual.

Keep this manual or a copy of it with the machine. If you lose this manual or need an additional copy, please contact our Corporation. This machine is built with user safety in mind; however, it can present hazards if improperly operated and serviced. Follow operating instructions carefully! If you have questions about operating or servicing this equipment, please contact us.

The information contained in this manual was based on machines in production at the time of publication. We reserves the right to change any portion of this information without notice.

All rights, especially copying and distribution rights are reserved.

## 2. Safety Information

This manual contains DANGER, WARNING, CAUTION, and NOTE callouts which must be followed to reduce the possibility of personal injury, damage to the equipment, or improper service.



This is the safety alert symbol. It is used to alert you to potential personal injury hazards. Obey all safety messages that follow this symbol to avoid possible injury or death.



**DANGER** indicates an imminently hazardous situation which, if not avoided, will result in death or serious injury.



**WARNING** indicates a potentially hazardous situation which, if not avoided, could result in death or serious injury.



**CAUTION** indicates a potentially hazardous situation which, if not avoided, may result in minor or moderate injury.

**CAUTION:** Used without the safety alert symbol, CAUTION indicates a

potentially hazardous situation which, if not avoided, may result in property damage.

**Note:** *Contains additional information important to a procedure.*

## 2.1 Laws Pertaining to Spark Arresters

**Notice:** State Health Safety Codes and Public Resources Codes specify that in certain locations spark arresters be used on internal combustion engines that use hydrocarbon fuels. A spark arrester is a device designed to prevent accidental discharge of sparks or flames from the engine exhaust. Spark arresters are qualified and rated by the United States Forest Service for this purpose.

In order to comply with local laws regarding spark arresters, consult the engine distributor or the local Health and Safety Administrator.

## 2.2 Operating Safety



**WARNING:** Familiarity and proper training are required for the safe operation of equipment! Equipment operated improperly or by untrained personnel can be dangerous! Read the operating instructions contained in both this manual and the engine manual and familiarize yourself with the location and proper use of all controls. Inexperienced operators should receive instruction from someone familiar with the equipment before being allowed to operate the machine.

- 2.2.1 **NEVER** allow anyone to operate this equipment without proper training. People operating this equipment must be familiar with the risks and hazards associated with it.
- 2.2.2 **NEVER** touch the engine or muffler while the engine is on or immediately after it has been turned off. These areas get hot and may cause burns.
- 2.2.3 **NEVER** use accessories or attachments that are not recommended by us. Damage to equipment and injury to the user may result.
- 2.2.4 **NEVER** operate the machine with the belt guard missing. Exposed drive belt and pulleys create potentially dangerous hazards that can cause serious injuries.
- 2.2.5 **NEVER** leave machine running unattended.
- 2.2.6 **ALWAYS** be sure operator is familiar with proper safety precautions and operation techniques before using machine.
- 2.2.7 **ALWAYS** wear protective clothing appropriate to the job site when operating equipment.
- 2.2.8 **ALWAYS** wear hearing protection when operating equipment.

- 2.2.9 **ALWAYS** close fuel valve on engines equipped with one when machine is not being operated.
- 2.2.10 **ALWAYS** store equipment properly when it is not being used. Equipment should be stored in a clean, dry location out of the reach of children.
- 2.2.11 **ALWAYS** operate machine with all safety devices and guards in place and in working order. **DO NOT** modify or defeat safety devices. **DO NOT** operate machine if any safety devices or guards are missing or inoperative.
- 2.2.12 **ALWAYS** read, understand, and follow procedures in Operator's Manual before attempting to operate equipment.

### 2.3 Operator Safety while using Internal Combustion Engines



**DANGER:** Internal combustion engines present special hazards during operation and fueling! Read and follow warning instructions in engine owner's manual and safety guidelines below. Failure to follow warnings and safety guidelines could result in severe injury or death.

- 2.3.1 **DO NOT** run machine indoors or in an enclosed area such as a deep trench unless adequate ventilation, through such items as exhaust fans or hoses, is provided. Exhaust gas from the engine contains poisonous carbon monoxide gas; exposure to carbon monoxide can cause loss of consciousness and may lead to death.
- 2.3.2 **DO NOT** smoke while operating machine.
- 2.3.3 **DO NOT** smoke when refueling engine.
- 2.3.4 **DO NOT** refuel hot or running engine.
- 2.3.5 **DO NOT** refuel engine near open flame.
- 2.3.6 **DO NOT** spill fuel when refueling engine.
- 2.3.7 **DO NOT** run engine near open flames.
- 2.3.8 **ALWAYS** refill fuel tank in well-ventilated area.
- 2.3.9 **ALWAYS** replace fuel tank cap after refueling.
- 2.3.10 **ALWAYS** check fuel lines and fuel tank for leaks and cracks before starting engine. Do not run machine if fuel leaks are present or fuel lines are loose.

## 2.4 Service Safety



**WARNING:** Poorly maintained equipment can become a safety hazard! In order for the equipment to operate safely and properly over a long period of time, periodic maintenance and occasional repairs are necessary.

- 2.4.1 **DO NOT** attempt to clean or service machine while it is running. Rotating parts can cause severe injury.
- 2.4.2 **DO NOT** crank a flooded engine with the spark plug removed on gasoline-powered engines. Fuel trapped in the cylinder will squirt out the spark plug opening.
- 2.4.3 **DO NOT** test for spark on gasoline-powered engines, if engine is flooded or the smell of gasoline is present. A stray spark could ignite fumes.
- 2.4.4 **DO NOT** use gasoline or other types of fuels or flammable solvents to clean parts, especially in enclosed areas. Fumes from fuels and solvents can become explosive.
- 2.4.5 **ALWAYS** keep area around muffler free of debris such as leaves, paper, cartons, etc. A hot muffler could ignite them, starting a fire.
- 2.4.6 **ALWAYS** replace worn or damaged components with spare parts designed and recommended by us.
- 2.4.7 **ALWAYS** disconnect spark plug on machines equipped with gasoline engines, before servicing, to avoid accidental start-up.
- 2.4.8 **ALWAYS** keep machine clean and labels legible. Replace all missing and hard-to-read labels. Labels provide important operating instructions and warn of dangers and hazards.



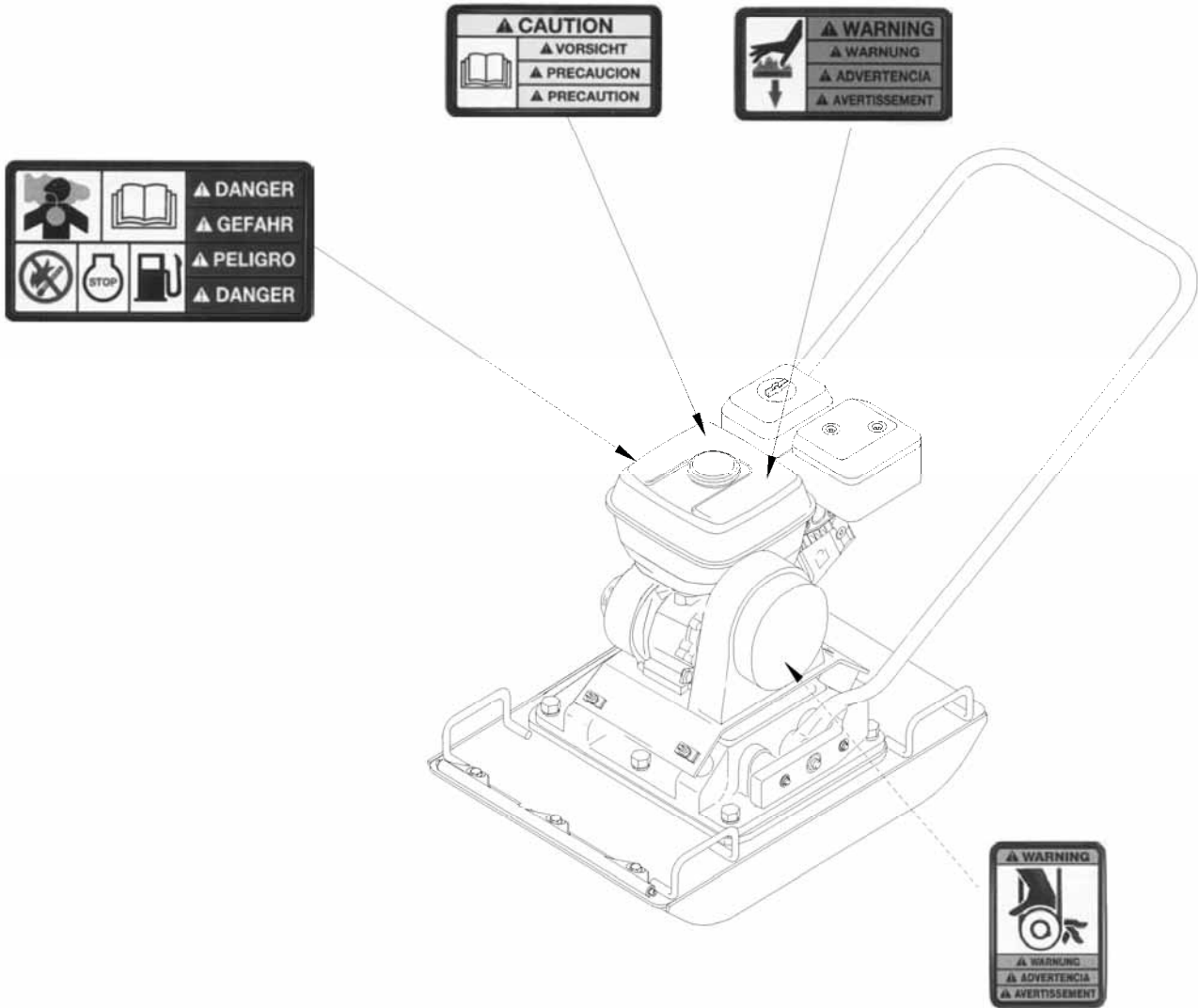

## 2.5 Label Locations

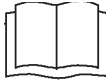

Graphic 1

## 2.6 Warning and Informational Labels



This machines use international pictorial labels where needed. These labels are described below:

| Label   | Meaning  |
|---|--|
|    | <p>To prevent hearing loss, wear hearing protection when operating this machine.</p>   |
|    | <p>Read the operator's manual for machine information.</p>   |
|    | <p><b>WARNING!</b><br/>Hot surface.</p>  |
|  | <p><b>WARNING!</b> Hand injury if caught in moving belt. Always replace belt guard.</p>  |
|  | <p><b>CAUTION!</b> Read and understand the supplied operator's manual before operating this machine. Failure to do so increases the risk of injury to yourself or others.</p>                              |
|  | <p><b>DANGER!</b> Engines emit carbon monoxide; operate only in well ventilated area. Read the operator's manual. No sparks, flames or burning objects near machine. Shut off engine before refueling.</p> |

## 2.7 Operating Labels

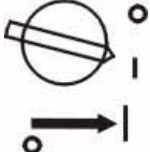
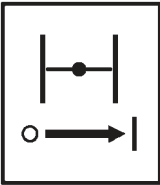
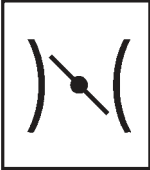
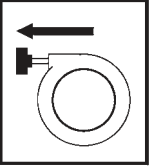
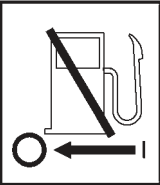
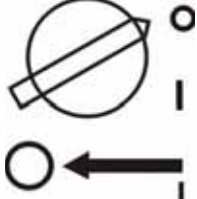
This machines use international pictorial labels where needed. These labels are described below:

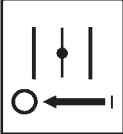
| Label   | Meaning                                     |
|---|---|
|    | Open fuel flow valve.                       |
|    | Push or turn engine switch to ON position.  |
|   | Close choke.                                |
|  | Place throttle in the IDLE position.        |
|  | Pull rewind starter.                        |
|  | Close fuel flow valve.                      |
|  | Push or turn engine switch to OFF position. |

| Label   |   | Meaning  |
|---|---|--|
|   |  | Open choke.  |
|   |  | Place throttle in the FAST position.                                   |
|  |   | Throttle control lever: Rabbit = Full or Fast<br>Turtle = Idle or Slow |

### 3. Technical Data

#### 3.1 Engine Data

|                        |          |   |
|------------------------|----------|---|
| Model                  |          | <b>PDZ2045</b>                              |
| Engine Model           |          | 168F  |
| Rated Power            | kW (Hp)  | 4.8 (6.5)                                   |
| Engine Speed - full    | rpm      | 3600 ± 100                                  |
| Engine Speed - idle    | rpm      | 1400 ± 100                                  |
| Valve Clearance (cold) | mm (in.) | Inlet: 0.15 (0.006)<br>Outlet: 0.20 (0.008) |
| Air Cleaner            | type     | Dual Element                                |
| Engine Lubrication     |          | SAE 10W30<br>SG, SF or SE                   |
| Engine Oil Capacity    | L (oz.)  | 0.6 (20)                                    |
| Fuel                   | type     | Regular unleaded gasoline                   |
| Fuel Tank Capacity     | L (qts.) | 3.6 (4.0)                                   |
| Spark Plug             | type     | (NGK) BPR 6ES, F7RTC                        |
| Electrode Gap          | mm (in)  | 0.7-0.8 (0.028-0.031)                       |

#### 3.2 Machine Data

|                     |            |                         |
|---------------------|------------|-------------------------|
| Model               |            | <b>PDZ2045</b>          |
| <b>Plate</b>        |            |                         |
| Operating Weight    | kg (lbs.)  | 100 (220)               |
| Exciter Speed       | rpm / belt | 5600 ± 100              |
| Climb Ability       |            | 0~20°                   |
| Exciter Lubrication |            | Shell Alvania #2 grease |

#### 3.3 Sound and Vibration Specifications

The required sound specifications, per Appendix 1, Paragraph 1.7.4.f of the EC-Machine Regulations, are:

\* The sound pressure level at operator's location (LpA) = 98 dB(A)

\* The sound power level (LWA) = 109 dB(A)

These sound values were determined according to ISO 3744 for the sound power level (LWA) and ISO 6081 for the sound pressure level (LpA) at the operator's location.

The weighted effective acceleration value, determined according to ISO 8662 Part 1, is: 3.2 m/s<sup>2</sup>.

The sound and vibration specifications were obtained with the unit operating on crushed gravel at nominal engine speed.

### 3.4 Dimensions

Mm (in.)

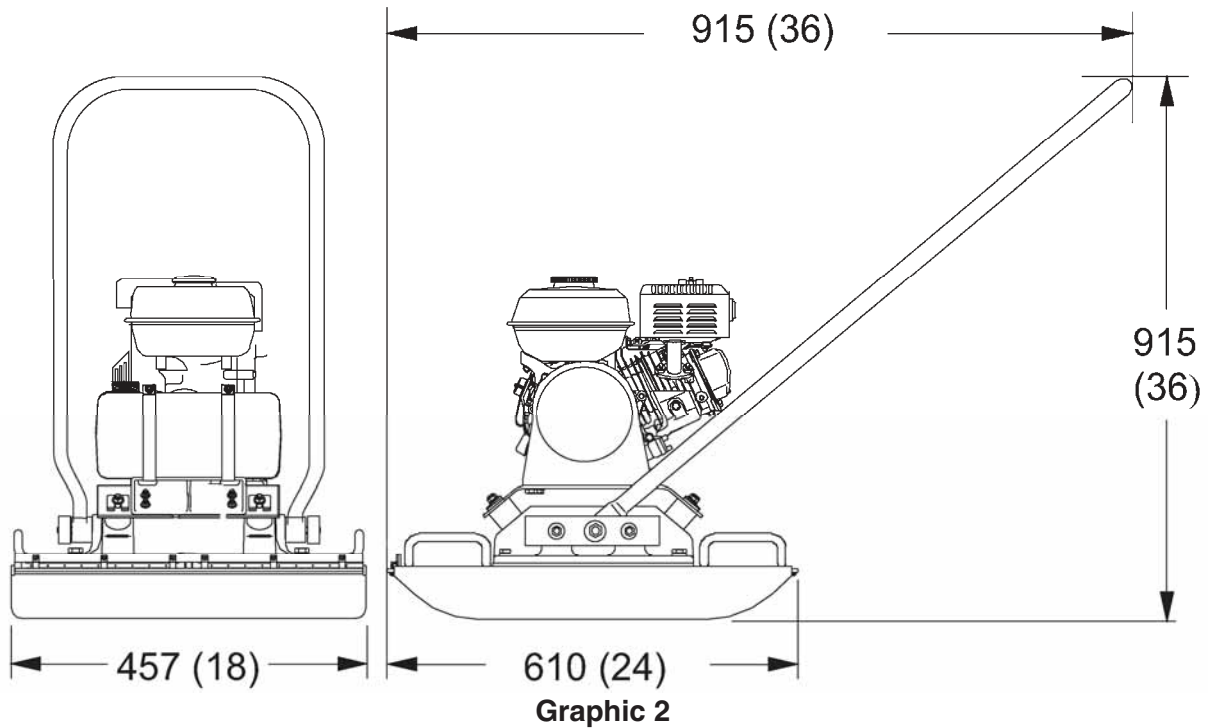

## 4. Operation

### 4.1 Recommended Fuel

The engine requires regular grade unleaded gasoline. Use only fresh, clean gasoline. Gasoline containing water or dirt will damage fuel system. Consult engine owner's manual for complete fuel specifications.

### 4.2 Before Starting

4.2.1 Read and understand safety and operating instructions at beginning of this manual.

4.2.2 Check:

- Oil level in engine.
- Fuel level.
- Condition of air cleaner.
- Tightness of external fasteners.
- Condition of fuel lines.

### 4.3 To Start

*See Graphic 3*

4.3.1 Open fuel valve by moving lever to the right (**a1**).

**Note:** *If engine is cold, move choke lever to close position (**b1**). If engine is hot, set choke to open position (**b2**).*

4.3.2 Turn engine switch to "ON" (**e1**).

4.3.3 Open throttle by moving it slightly to left (**d1**).

4.3.4 Pull starter rope (**c**).

**Note:** *If the oil level in the engine is low, the engine will not start. If this happens, add oil to engine. Some engines are equipped with an oil alert light that will come on while pulling the starter rope.*

4.3.5 Open choke as engine warms (**b2**).

4.3.6 Open throttle fully to operate.

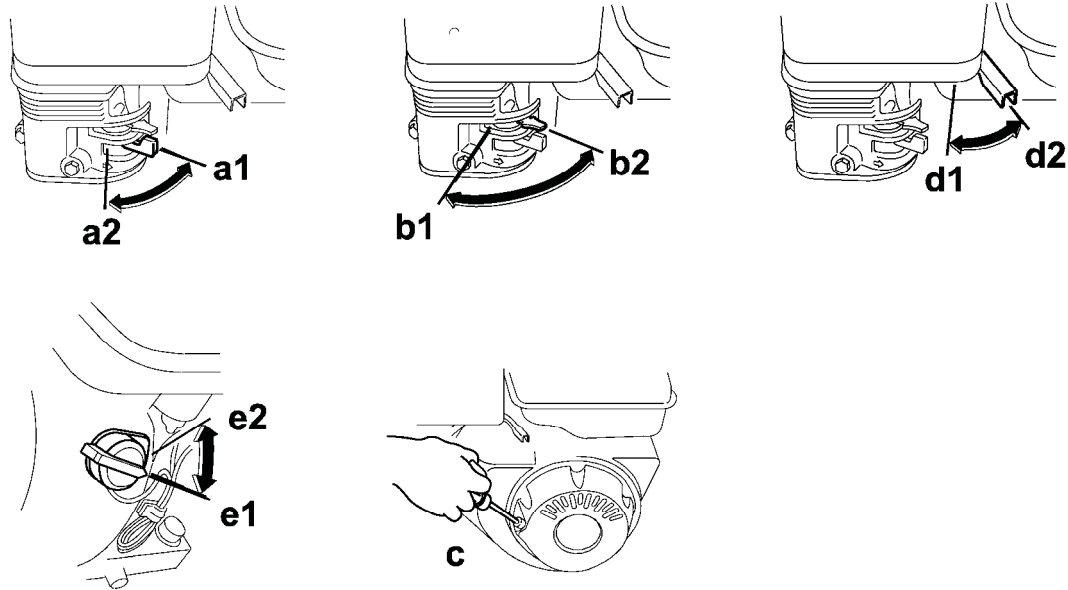

**Graphic 3**

#### **4.4 To Stop**

*See Graphic 3*

- 4.4.1 Reduce engine RPM to idle by moving throttle completely to right (d2).
- 4.4.2 Turn engine switch to “OFF” (e2).
- 4.4.3 Close fuel valve by moving lever to the left (a2).

#### **4.5 Application**

This plate is designed for compacting loose, granular soils, gravel, and paving stones. It is intended to be used in confined areas and areas next to structures such as walls, curbs, and foundations. Plates equipped with water tanks can be used for compacting asphalt.

This plate is not recommended for compacting cohesive soils with a heavy clay content. For cohesive soil, use a vibratory rammer or sheepfoot roller.

#### **4.6 Operation**

Run the engine at full throttle and allow the plate to pull itself along at its normal speed. When operating on an incline it may be necessary to assist the plate by pushing it forward slightly. When operating downhill hold the plate back slightly, if it begins to pick up speed. Depending on the material being compacted, three or four passes are recommended to achieve the best compaction.

While a certain amount of moisture in the soil is necessary, excessive moisture may cause

soil particles to stick together and prevent good compaction. If soil is extremely wet, allow it to dry somewhat before compacting.

If soil is so dry as to create dust clouds while operating plate, some moisture should be added to the ground material to improve compaction. This will also reduce service to the air filter.

For compacting asphalt, use a water tank to wet the asphalt and the underside of plate. This will prevent asphalt material from sticking. Two passes are usually sufficient to ensure good compaction.

When using the plate on paving stones, attach a pad to the bottom of the plate to prevent chipping or grinding surface of stones. A special polyurethane pad designed for this purpose is available as an optional accessory.

**CAUTION:** DO NOT operate the plate on concrete or on extremely hard, dry, compacted surfaces. The plate will jump rather than vibrate and could damage both the plate and the engine.

## 5. Maintenance

### 5.1 Periodic Maintenance Schedule

The chart below lists basic engine maintenance. Refer to engine manufacturer's Operation Manual for additional information on engine maintenance.

|  | Daily before starting | After first 20 hrs. | Every 2 weeks or 50 hrs. | Every month or 100 hrs. | Every year or 300 hrs. |
|--|-----------------------|---------------------|--------------------------|-------------------------|------------------------|
| Check fuel level.                      | ●                     |                     |                          |                         |                        |
| Check engine oil level.                | ●                     |                     |                          |                         |                        |
| Inspect fuel lines.                    | ●                     |                     |                          |                         |                        |
| Inspect air filter. Replace as needed. | ●                     |                     |                          |                         |                        |
| Check and tighten external hardware.   | ●                     |                     |                          |                         |                        |
| Check and adjust drive belt.           |                       | ●                   |                          |                         |                        |
| Clean air cleaner elements.            |                       |                     | ●                        |                         |                        |
| Inspect shock mounts for damage.       |                       |                     | ●                        |                         |                        |
| Change engine oil.                     |                       | ●                   |                          |                         |                        |
| Clean cooling system.                  |                       |                     |                          | ●                       |                        |
| Clean sediment cup / fuel filter.      |                       |                     |                          | ●                       |                        |
| Check and clean spark plug.            |                       |                     |                          | ●                       |                        |
| Check and adjust valve clearance.      |                       |                     |                          |                         | ●                      |
| Grease exciter bearing.                |                       |                     |                          |                         | ●                      |

### 5.2 Cleaning Plate

Clean plate after use to remove dirt, stones, and mud caught under the engine console. If plate is being used in a dusty area, check engine cylinder cooling fins for heavy dirt accumulation. Keep engine cylinder fins clean to prevent engine from overheating.

### 5.3 Drive Belt

*See Graphic 4*

On new machines or after installing a new belt, check belt tension after first five hours of operation. Check and adjust belt every 50 hours thereafter.

To adjust belt:

5.3.1 Loosen hardware **(b)** securing belt cover to engine plate and remove cover.

5.3.2 Loosen nuts **(a)** securing engine plate to base plate.

5.3.3 Remove spacers **(c)** and insert them as needed underneath the engine plate. Shim machine front to back, not side to side. Shim belt so that it deflects 10–13 mm (3/8"–1/2") when pressed midway between belt pulleys.

5.3.4 Re-install belt cover and tighten all hardware.

**Note:** *When installing a new belt, install spacers on top of engine plate.*

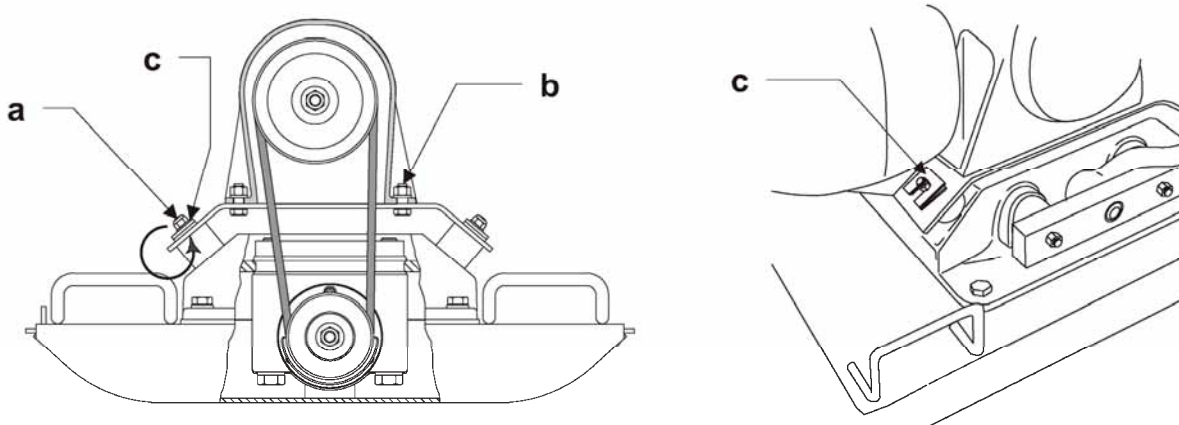

**Graphic 4**

## 5.4 Spark Plug

*See Graphic 5*

Clean or replace spark plug as needed to ensure proper operation. Refer to the engine Owner's Manual.



**WARNING:** The muffler becomes very hot during operation and remains hot for awhile after stopping the engine. Do not touch the muffler while it is hot.

**Note:** *Refer to the Technical Data for the recommended spark plug type and the electrode gap setting.*

5.4.1 Remove spark plug and inspect it.

5.4.2 Replace plug if the insulator is cracked or chipped.

5.4.3 Clean spark plug electrodes with a wire brush.

5.4.4 Set the electrode gap (**a**).

5.4.5 Tighten spark plug securely.

**CAUTION:** A loose spark plug can become very hot and may cause engine damage.

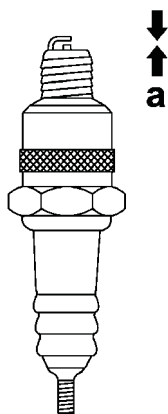

**Graphic 5**

## 5.5 Engine Oil

*See Graphic 6*

5.5.1 Drain oil while the engine is still warm.

5.5.2 Remove the oil fill plug (**a**) and drain plug (**b**) to drain oil.

**Note:** *In the interests of environmental protection, place a plastic sheet and a container under the machine to collect any liquid which drains off. Dispose of this liquid in accordance with environmental protection legislation.*

5.5.3 Install drain plug.

5.5.4 Fill the engine crankcase with recommended oil up to the level of the plug opening (**c**). See Technical Data for oil quantity and type.

5.5.5 Install the oil filler plug.

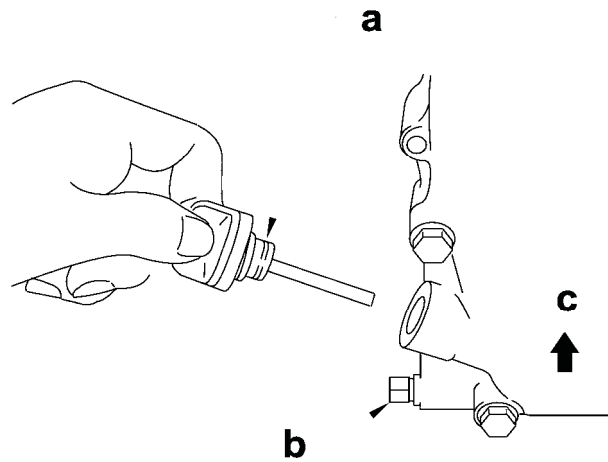

Graphic 6

## 5.6 Air Cleaner

See Graphic 7

The engine is equipped with a dual element air cleaner. Service air cleaner frequently to prevent carburetor malfunction.

**CAUTION: NEVER** run engine without air cleaner. Severe engine damage will occur.



**WARNING: NEVER** use gasoline or other types of low flash point solvents for cleaning the air cleaner. A fire or explosion could result.

To service:

- 5.6.1 Remove air cleaner cover (a). Remove both elements and inspect them for holes or tears. Replace damaged elements.
- 5.6.2 Wash foam element (b) in solution of mild detergent and warm water. Rinse thoroughly in clean water. Allow element to dry thoroughly. Soak element in clean engine oil and squeeze out excess oil.
- 5.6.3 Tap paper element (c) lightly to remove excess dirt. Replace paper element if it appears heavily soiled.

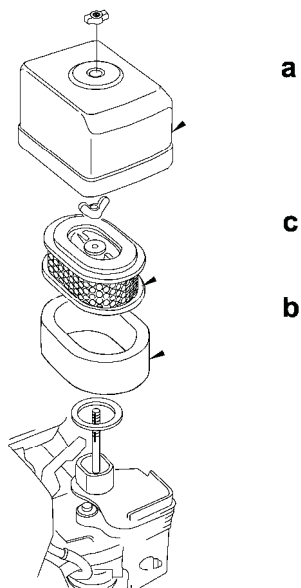

**Graphic 7**

## **5.7 Cleaning Sediment Cup**

*See Graphic 8*

- 5.7.1 Turn fuel valve off.
- 5.7.2 Remove sediment cup (a) and O-ring (b).
- 5.7.3 Wash both thoroughly in a nonflammable solvent. Dry and reinstall them.
- 5.7.4 Turn fuel valve on and check for leaks.

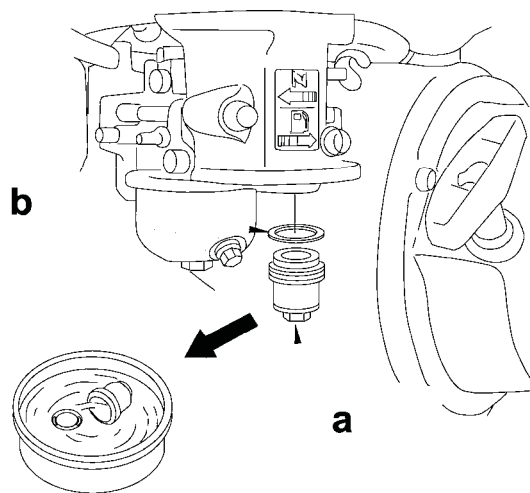

**Graphic 8**

## 5.8 Adjusting Engine Speed

See Graphic 9

Adjust to a full load speed of  $3600 \pm 100$  rpm. To adjust engine speed:

- 5.8.1 Place machine on a rubber test mat to prevent it from moving.
- 5.8.2 Start engine and allow it to warm up for a minute.
- 5.8.3 Turn throttle stop screw (a) in to increase speed, out to decrease speed. Make sure throttle lever is touching stop screw before measuring RPM.

**CAUTION:** Running plate at a speed higher than that listed in Technical Data can damage both the plate and the engine.

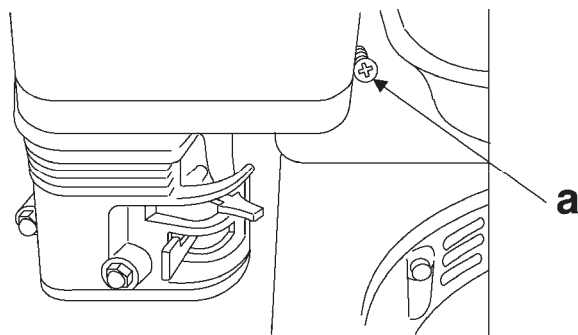

Graphic 9

## 5.9 Carburetor Adjustment

See Graphic 10

- 5.9.1 Start the engine and allow it to warm up to operating temperature.
- 5.9.2 Set the pilot screw (a) 2 turns out. See Note.
- 5.9.3 With the engine idling, turn the pilot screw (a) in or out to the setting that produces the highest rpm.
- 5.9.4 After the pilot screw is adjusted, turn the throttle stop screw (b) to obtain the standard idle speed. See Technical Data.

**Note:** On some engines the pilot screw is fitted with a limiter cap (c) to prevent excessive enrichment of the air-fuel mixture in order to comply with emission regulations. The mixture is set at the factory and no adjustment should be necessary. Do not attempt to remove the limiter cap. The limiter cap cannot be removed without breaking the pilot screw.

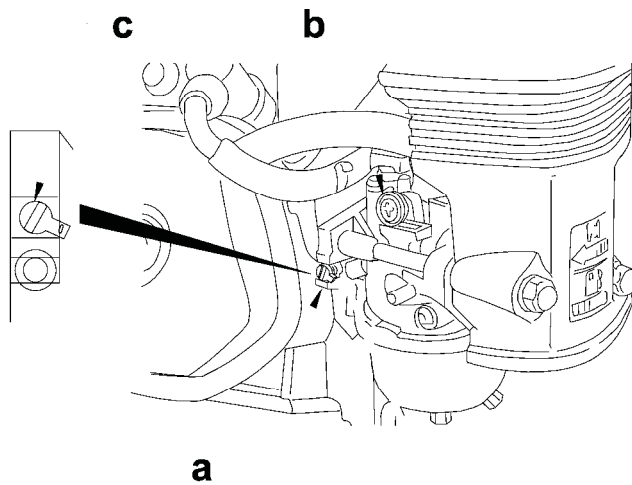

**Graphic 10**

### 5.10 Troubleshooting

| Problem / Symptom                                   | Reason / Remedy   |
|---|---|
| Plate does not develop full speed. Poor compaction. | <ul style="list-style-type: none"> <li>• Engine throttle control not completely open.</li> <li>• Throttle control not adjusted correctly.</li> <li>• Ground too wet, plate sticking. Allow soil to dry before compacting.</li> <li>• Drive belt loose or worn, slipping on pulleys. Adjust or replace belt.</li> <li>• Check that engine mounting bolts are tight.</li> <li>• Exciter bearings binding. Check condition and level of oil in exciter. Add or change oil.</li> <li>• Air filter clogged with dust, reducing engine performance. Clean or replace air filter.</li> <li>• Engine speed too low. Check engine speed with tachometer. Adjust or repair engine to run at correct speed. Refer to engine manual.</li> </ul> |
| Engine running, no vibration                        | <ul style="list-style-type: none"> <li>• Engine throttle not open.</li> <li>• Drive belt loose or broken. Adjust or replace.</li> <li>• Clutch damaged. Inspect and replace clutch.</li> <li>• Engine speed too low. Check engine speed.</li> <li>• Too much oil in exciter. Adjust oil to correct level.</li> </ul>  |
| Plate jumps or compacts unevenly.                   | <ul style="list-style-type: none"> <li>• Ground surface too hard.</li> <li>• Shock mounts loose or damaged.</li> </ul>  |

## 5.11 Storage

If plate is being stored for more than 30 days:

5.11.1 Remove loose stones and dirt from plate.

5.11.2 Clean engine cylinder cooling fins.

5.11.3 Clean or replace air filter.

5.11.4 Change engine oil and follow procedures described in engine manual for engine storage.

5.11.5 Cover plate and engine and store in a clean, dry area.

## 5.12 Lifting Machine

*See Graphic 11*

See Technical Data for weight of machine.

5.12.1 Stop the engine.

5.12.2 Obtain help from a partner and plan the lift.



**WARNING:** To avoid burns or fire hazards, let the engine cool before transporting the machine or storing it indoors. Turn the fuel valve to the off position and keep the engine level to prevent fuel from spilling.

5.12.3 Grasp machine by the lifting handles (**a**).

5.12.4 Lift machine as shown.



**WARNING:** To reduce risk of back injury while lifting, keep feet flat on ground and shoulder width apart. Keep head up and back straight.

**CAUTION:** DO NOT lift the vibroplate by its guide handle. The vibroplate can shift, causing it to fall.

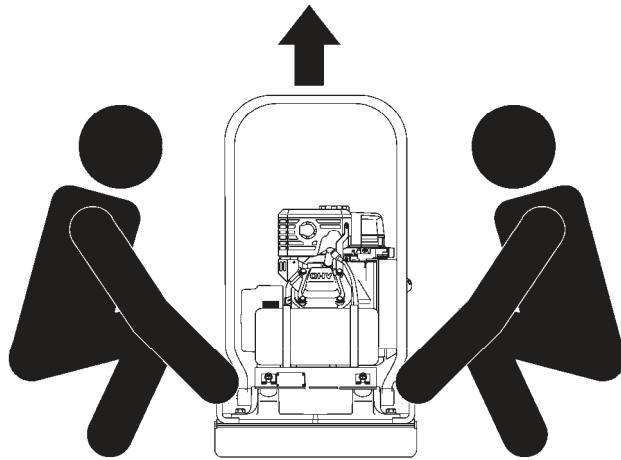

**Graphic 11**

### 5.13 Transporting Machine

*See Graphic 12*



**WARNING:** To avoid burns or fire hazards, let engine cool before transporting machine or storing indoors.

- 5.13.1 Turn fuel valve to the off position and keep the engine level to prevent fuel from spilling.
- 5.13.2 Tie down machine on vehicle to prevent machine from sliding or tipping over. Tie machine to vehicle at points shown on graphic.

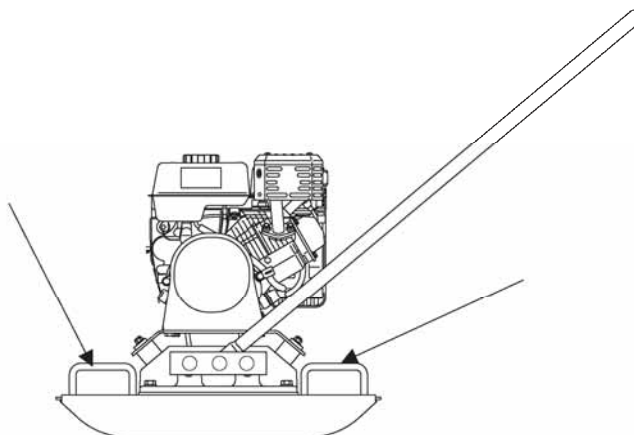

**Graphic 12**