

# **PDZB35**

## **Concrete Vibratory**

### **Owner's Manual**

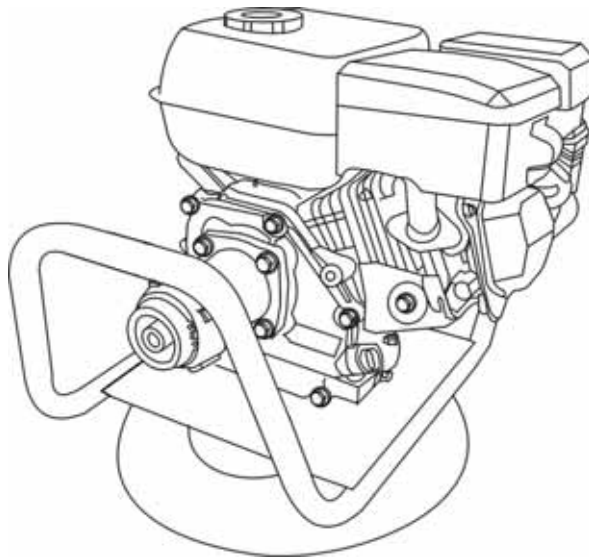

**SAVE THIS MANUAL FOR FUTURE REFERENCE**

This manual provides information regarding the operation and maintenance of these products. We have made every effort to ensure the accuracy of the information in this manual. We reserve the right to change this product at any time without prior notice.

Please keep this manual available to all users during the entire life of the Vibratory.

# TABLE OF CONTENTS

1. Foreword .....	3
2. Safety Information .....	4
2.1 Laws Pertaining to Spark Arresters .....	4
2.2 Operating Safety .....	5
2.3 Operator Safety while using Internal Combustion Engines ..	6
2.4 Service Safety .....	7
2.5 Label Locations .....	8
2.6 Warning and Informational Labels .....	9
2.7 Operating Labels .....	9
3. Technical Data .....	13
3.1 Engine Data .....	13
3.2 Power Unit .....	14
3.3 Sound and Measurements .....	14
4. Operation .....	16
4.1 Application .....	16
4.2 Recommended Fuel .....	16
4.3 Before Starting .....	16
4.4 Operation .....	18
4.5 To Start .....	16
4.6 To Stop .....	17
5. Maintenance .....	19
5.1 Periodic Maintenance Schedule .....	19
5.2 Engine Oil .....	22
5.3 Air Cleaner .....	23

5.4 Spark Plug .....	21
5.5 Carburetor Adjustment .....	25
5.6 Sediment Cup .....	24
5.7 Storage .....	26
5.8 Troubleshooting .....	26

## CALIFORNIA Proposition

### 65 Warning:



WARNING: Engine exhaust, some of its constituents, and certain vehicle components contain or emit chemicals known to the State of California to cause cancer and birth defects or other reproductive harm.

## 1. Foreword

This operator's manual contains information and procedures for the safe operation and maintenance of your unit. For your own safety and for protection against injury, you should read the safety instructions thoroughly, make yourself familiar with them and observe them at all times.

This operator's manual is not a manual for extensive maintenance and repair work. Such work should be carried out by our Service or authorised specialists.

The safety of the operator was one of the most important aspects when this unit was designed. However, improper use or incorrect maintenance can pose a risk. Please operate and service your unit in accordance with the specifications in this operator's manual. Your reward will be operation without any trouble and a high degree of availability.

Defective components should be replaced immediately!

Please contact your representative if you have any questions concerning operation or maintenance.

We expressly reserve the right to technical modifications - even without explicit prior notice - with the aim of improving our units or their safety standards.

## 2. Safety Information

This manual contains DANGER, WARNING, CAUTION, and NOTE callouts which must be followed to reduce the possibility of personal injury, damage to the equipment, or improper service.



This is the safety alert symbol. It is used to alert you to potential personal injury hazards. Obey all safety messages that follow this symbol to avoid possible injury or death.



**DANGER** indicates an imminently hazardous situation which, if not avoided, will result in death or serious injury.



**WARNING** indicates a potentially hazardous situation which, if not avoided, could result in death or serious injury.



**CAUTION** indicates a potentially hazardous situation which, if not avoided, may result in minor or moderate injury.

**CAUTION:** Used without the safety alert symbol, CAUTION indicates a potentially hazardous situation which, if not avoided, may result in property damage.

**Note:** *Contains additional information important to a procedure.*

## 2.1 Laws Pertaining to Spark Arresters

**Notice:** State Health Safety Codes and Public Resources Codes specify that in certain locations spark arresters be used on internal combustion engines that use hydrocarbon fuels. A spark arrester is a device designed to prevent accidental discharge of sparks or flames from the engine exhaust. Spark arresters are qualified and rated by the United States Forest Service for this purpose.

In order to comply with local laws regarding spark arresters, consult the engine distributor or the local Health and Safety Administrator.

## 2.2 Operating Safety



**WARNING:** Familiarity and proper training are required for the safe operation of equipment! Equipment operated improperly or by untrained personnel can be dangerous! Read the operating instructions contained in both this manual and the engine manual and familiarize yourself with the location and proper use of all controls. Inexperienced operators should receive instruction from someone familiar with the equipment before being allowed to operate the machine.

- 2.2.1 **NEVER** allow anyone to operate this equipment without proper training. People operating this equipment must be familiar with the risks and hazards associated with it.
- 2.2.2 **NEVER** touch the engine or muffler while the engine is on or immediately after it has been turned off. These areas get hot and may cause burns.
- 2.2.3 **NEVER** use accessories or attachments that are not recommended by us. Damage to equipment and injury to the user may result.
- 2.2.4 **NEVER** operate the machine with the belt guard missing. Exposed drive belt and pulleys create potentially dangerous hazards that can cause serious injuries.
- 2.2.5 **NEVER** leave machine running unattended.

- 2.2.6 **ALWAYS** be sure operator is familiar with proper safety precautions and operation techniques before using machine.
- 2.2.7 **ALWAYS** wear protective clothing appropriate to the job site when operating equipment.
- 2.2.8 **ALWAYS** wear hearing protection when operating equipment.
- 2.2.9 **ALWAYS** close fuel valve on engines equipped with one when machine is not being operated.
- 2.2.10 **ALWAYS** store equipment properly when it is not being used. Equipment should be stored in a clean, dry location out of the reach of children.
- 2.2.11 **ALWAYS** operate machine with all safety devices and guards in place and in working order. **DO NOT** modify or defeat safety devices. **DO NOT** operate machine if any safety devices or guards are missing or inoperative.
- 2.2.12 **ALWAYS** read, understand, and follow procedures in Operator's Manual before attempting to operate equipment.

### 2.3 Operator Safety while using Internal Combustion Engines



**DANGER:** Internal combustion engines present special hazards during operation and fueling! Read and follow warning instructions in engine owner's manual and safety guidelines below. Failure to follow warnings and safety guidelines could result in severe injury or death.

- 2.3.1 **DO NOT** run machine indoors or in an enclosed area such as a deep trench unless adequate ventilation, through such items as exhaust fans or hoses, is provided. Exhaust gas from the engine contains poisonous carbon monoxide gas; exposure to carbon monoxide can cause loss of consciousness and may lead to death.
- 2.3.2 **DO NOT** smoke while operating machine.
- 2.3.3 **DO NOT** smoke when refueling engine.
- 2.3.4 **DO NOT** refuel hot or running engine.
- 2.3.5 **DO NOT** refuel engine near open flame.
- 2.3.6 **DO NOT** spill fuel when refueling engine.
- 2.3.7 **DO NOT** run engine near open flames.
- 2.3.8 **ALWAYS** refill fuel tank in well-ventilated area.
- 2.3.9 **ALWAYS** replace fuel tank cap after refueling.

- 2.3.10 **ALWAYS** check fuel lines and fuel tank for leaks and cracks before starting engine. Do not run machine if fuel leaks are present or fuel lines are loose.

## 2.4 Service Safety



**WARNING:** Poorly maintained equipment can become a safety hazard! In order for the equipment to operate safely and properly over a long period of time, periodic maintenance and occasional repairs are necessary.

- 2.4.1 **DO NOT** attempt to clean or service machine while it is running. Rotating parts can cause severe injury.
- 2.4.2 **DO NOT** crank a flooded engine with the spark plug removed on gasoline-powered engines. Fuel trapped in the cylinder will squirt out the spark plug opening.
- 2.4.3 **DO NOT** test for spark on gasoline-powered engines, if engine is flooded or the smell of gasoline is present. A stray spark could ignite fumes.
- 2.4.4 **DO NOT** use gasoline or other types of fuels or flammable solvents to clean parts, especially in enclosed areas. Fumes from fuels and solvents can become explosive.
- 2.4.5 **ALWAYS** keep area around muffler free of debris such as leaves, paper, cartons, etc. A hot muffler could ignite them, starting a fire.
- 2.4.6 **ALWAYS** replace worn or damaged components with spare parts designed and recommended by us.
- 2.4.7 **ALWAYS** disconnect spark plug on machines equipped with gasoline engines, before servicing, to avoid accidental start-up.
- 2.4.8 **ALWAYS** keep machine clean and labels legible. Replace all missing and hard-to-read labels. Labels provide important operating instructions and warn of dangers and hazards.



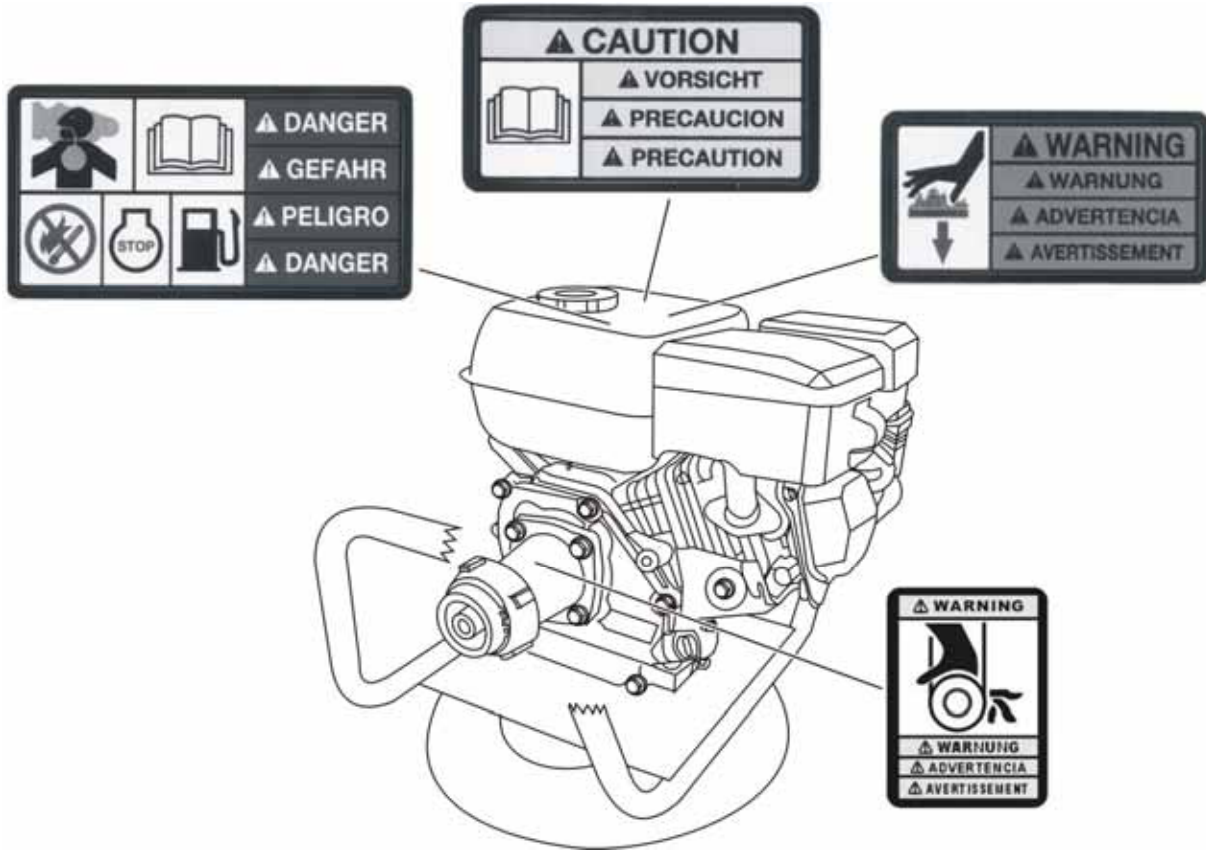

## 2.5 Label Locations



Graphic 1

## 2.6 Warning and Informational Labels



Our machines use international pictorial labels where needed. These labels are described below:

Label	Meaning
	<p><b>DANGER!</b> Engines emit carbon monoxide; operate only in well ventilated area. Read the operator's manual. No sparks, flames or burning objects near machine. Shut off engine before refueling.</p>
	<p><b>WARNING!</b> Hot surface.</p>
	<p><b>WARNING!</b> Hand injury if caught in moving belt Always replace belt guard</p>
	<p><b>CAUTION!</b> Read and understand the supplied operator's manuals before operating this machine. Failure to do so increases the risk of injury to yourself or others.</p>

## 2.7 Operating Labels

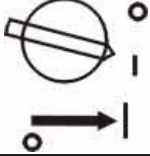
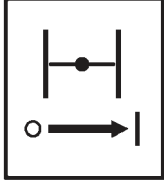
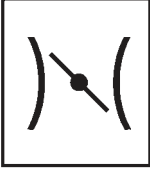
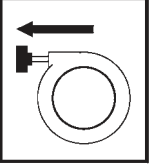
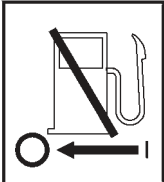
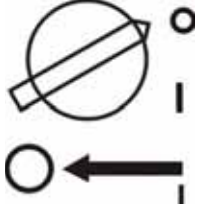
This machines use international pictorial labels where needed. These labels are described below:

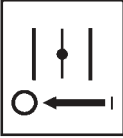
Label	Meaning
	Open fuel flow valve.
	Push or turn engine switch to ON position.
	Close choke.
	Place throttle in the IDLE position.
	Pull rewind starter.
	Close fuel flow valve.
	Push or turn engine switch to OFF position.

Label		Meaning
		Open choke.
		Place throttle in the FAST position.
		Throttle control lever: Rabbit = Full or Fast Turtle = Idle or Slow

### 3. Technical Data

#### 3.1 Engine

Model		PDZB35
Engine Model		168F
Rated Power	kW (Hp)	4.8 (6.5)
Spark Plug		NGK BPR 6ES, F7RTC
Electrode Gap	mm (in.)	0.7-0.8 (0.028–0.031)
Engine Speed - full load	rpm	3600 ± 100
Engine Speed - idle	rpm	1400 ± 100
Air Cleaner	type	Dual element
Engine Lubrication	oil grade	SAE 10W30 SG or SF
Engine Oil Capacity	L (oz.)	0.6 (20)
Fuel	type	Regular unleaded gasoline
Fuel Tank Capacity	L (qts.)	3.6 (3.8)
Fuel Consumption	L(qts.) / hr.	1.7 (1.8)

#### 3.2 Power Unit

Model		PDZB35
Power Unit		
Dimensions (l x w x h)	mm (in)	587 x 422 x 400 (23 x 16.5 x 16)
Weight	kg (lbs.)	64 (141)
Speed (no load)	rpm	10,000

#### 3.3 Sound Measurements

The required sound specification, Paragraph 1.7.4.f of 89/392/EEC Machinery Directive, is:

\* The sound pressure level at operator's location (LpA) = TBD\* dB(A)

\* the guaranteed sound power level (LWA) = TBD\* dB(A).

These sound values were determined according to ISO 3744 for the sound power level (LWA) and ISO 6081 for the sound pressure level(LpA) at the operator's location.

The weighted effective acceleration value, determined according to ISO 8662 Part 1, is TBD\* m/s<sup>2</sup>.

The sound and vibration measurements were obtained with the unit operating at nominal speed.

\*TBD = To Be Determined.

## 4. Operation

### 4.1 Application

This power unit is intended for on-site vibration of concrete for foundations, walls, columns, slab work, etc. For in-plant vibration of concrete during the production of pipes, slabs, beams, double T's, columns and walls, we recommend the use of electric power units.

### 4.2 Recommended Fuel

The engine requires regular grade unleaded gasoline. Use only fresh, clean gasoline. Gasoline containing water or dirt will damage fuel system. Consult engine owner's manual for complete fuel specifications.

### 4.3 Before Starting

- 4.3.1 Read safety instructions at the beginning of this manual.
- 4.3.2 Place the unit on a firm, flat, level surface.
- 4.3.3 Check fuel level, engine oil level, and condition of air cleaner.

### 4.4 Operation

*See Graphic 2*

- 4.4.1 Start the engine without a flex-shaft attached to the power unit, run the engine for 1½–2 minutes to allow it to warm up, then shut it off.

**Note:** *The power unit is designed to accept a quick-disconnect coupler in order to make it easier to attach a flex-shaft.*

- 4.4.2 Attach the flex-shaft as follows:

- Circumgyrate deasil the quick connect nozzle (**b**)
- Align the coupler-shaft combination with the power unit coupling hub (**a**).
- Loosen, then the quick connect nozzle (**b**) reset automatically, pull flex-shaft forth, if it doesn't fall out, indicate it have been connect well, and the coupler is held securely in place.



**WARNING:** Do not attach the flex-shaft while the engine is running! Hand injury could result!

- 4.4.3 Start the engine and run it at full speed while operating the power unit.

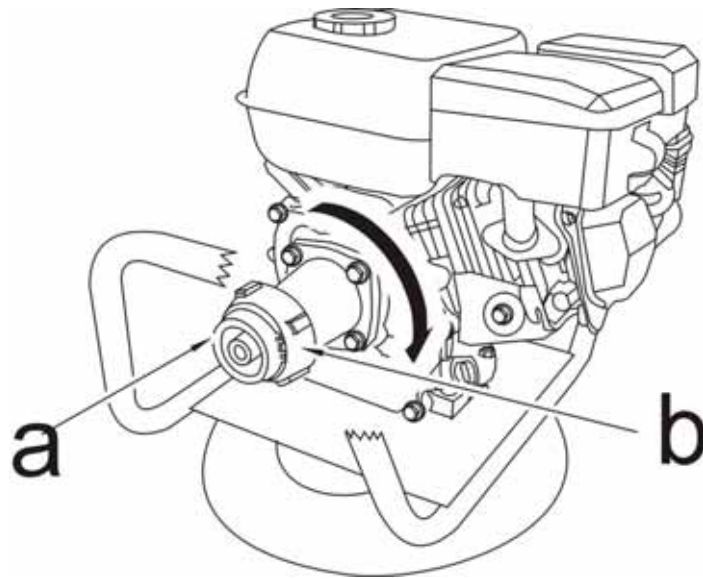

**Graphic 2**

## **4.5 To Start**

*See Graphic 3*

4.5.1 Open fuel valve by moving lever to the right (**a1**).

**Note:** *If engine is cold, move choke lever to close position (**b1**). If engine is hot, set choke to open position (**b2**).*

4.5.2 Turn engine switch to “ON” (**e1**).

4.5.3 Open throttle by moving it slightly to left (**d1**).

4.5.4 Pull starter rope (**c**).

**Note:** *If the oil level in the engine is low, the engine will not start. If this happens, add oil to engine. Some engines are equipped with an oil alert light that will come on while pulling the starter rope.*

4.5.5 Open choke as engine warms (**b2**).

4.5.6 Open throttle fully to operate.

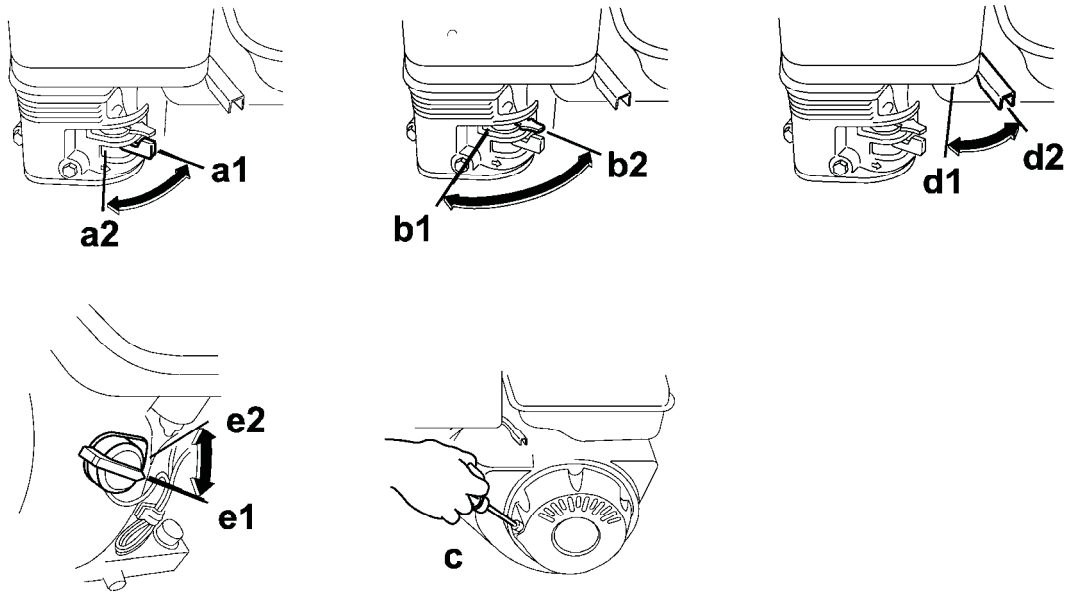

Graphic 3

## 4.6 To Stop

*See Graphic 3*

- 4.6.1 Reduce engine RPM to idle by moving throttle completely to right (d2).
- 4.6.2 Turn engine switch to “OFF” (e2).
- 4.6.3 Close fuel valve by moving lever to the left (a2).

## 5. Maintenance

### 5.1 Periodic Maintenance Schedule

The chart below lists basic machine and engine maintenance. Refer to engine manufacturer's Operator's Manual for additional information on engine maintenance.

	Daily before starting	After first 20 hrs.	Every 50 hrs.	Every 100 hrs.	Every 300 hrs.
Check fuel level.	●				
Check engine oil level.	●				
Inspect air filter. Replace as needed.	●				
Change engine oil.		●		●	
Clean air cleaner.			●		
Clean sediment cup.				●	
Check and clean spark plug.				●	
Check and adjust valve clearance.					●

### 5.2 Engine Oil

*See Graphic 4*

5.2.1 Drain oil while the engine is still warm.

5.2.2 Remove the oil fill plug (a) and drain plug (b) to drain oil.

**Note:** *In the interests of environmental protection, place a plastic sheet and a container under the machine to collect any liquid which drains off. Dispose of this liquid in accordance with environmental protection legislation.*

5.2.3 Install drain plug.

5.2.4 Fill the engine crankcase with recommended oil up to the level of the plug opening (c). See Technical Data for oil quantity and type.

5.2.5 Install the oil filler plug.

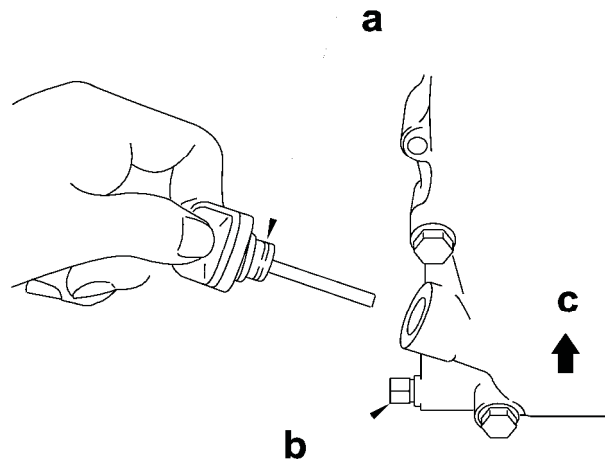

Graphic 4

### 5.3 Air Cleaner

See Graphic 5

The engine is equipped with a dual element air cleaner. Service air cleaner frequently to prevent carburetor malfunction.

**CAUTION:** NEVER run engine without air cleaner. Severe engine damage will occur.



**WARNING:** NEVER use gasoline or other types of low flash point solvents for cleaning the air cleaner. A fire or explosion could result.

To service:

- 5.3.1 Remove air cleaner cover (a). Remove both elements and inspect them for holes or tears. Replace damaged elements.
- 5.3.2 Wash foam element (b) in solution of mild detergent and warm water. Rinse thoroughly in clean water. Allow element to dry thoroughly. Soak element in clean engine oil and squeeze out excess oil.
- 5.3.3 Tap paper element (c) lightly to remove excess dirt. Replace paper element if it appears heavily soiled.

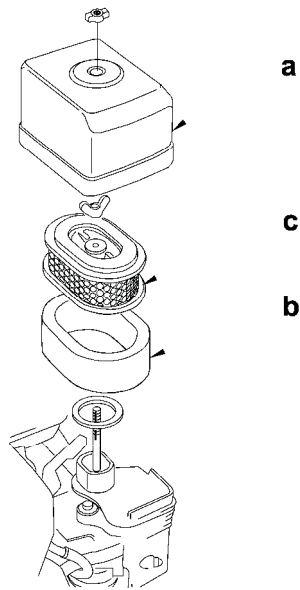

**Graphic 5**

## 5.4 Spark Plug

*See Graphic 6*

Clean or replace spark plug as needed to ensure proper operation. Refer to the engine Owner's Manual.



**WARNING:** The muffler becomes very hot during operation and remains hot for awhile after stopping the engine. Do not touch the muffler while it is hot.

**Note:** *Refer to the Technical Data for the recommended spark plug type and the electrode gap setting.*

- 5.4.1 Remove spark plug and inspect it.
- 5.4.2 Replace plug if the insulator is cracked or chipped.
- 5.4.3 Clean spark plug electrodes with a wire brush.
- 5.4.4 Set the electrode gap (**a**).
- 5.4.5 Tighten spark plug securely.

**CAUTION:** A loose spark plug can become very hot and may cause engine damage.

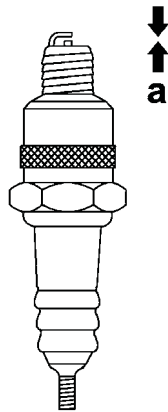

**Graphic 6**

## 5.5 Carburetor Adjustment

See *Graphic 7*

5.5.1 Start the engine and allow it to warm up to operating temperature.

5.5.2 Set the pilot screw (a) 2 turns out. See Note.

5.5.3 With the engine idling, turn the pilot screw (a) in or out to the setting that produces the highest rpm.

5.5.4 After the pilot screw is adjusted, turn the throttle stop screw (b) to obtain the standard idle speed. See Technical Data.

**Note:** *On some engines the pilot screw is fitted with a limiter cap (c) to prevent excessive enrichment of the air-fuel mixture in order to comply with emission regulations. The mixture is set at the factory and no adjustment should be necessary. Do not attempt to remove the limiter cap. The limiter cap cannot be removed without breaking the pilot screw.*

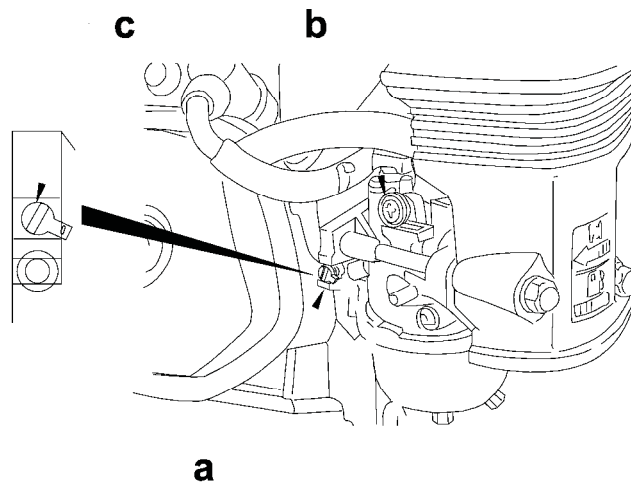

**Graphic 7**

## 5.6 Cleaning Sediment Cup

See *Graphic 8*

- 5.6.1 Turn fuel valve off.
- 5.6.2 Remove sediment cup (a) and O-ring (b).
- 5.6.3 Wash both thoroughly in a nonflammable solvent. Dry and reinstall them.
- 5.6.4 Turn fuel valve on and check for leaks.

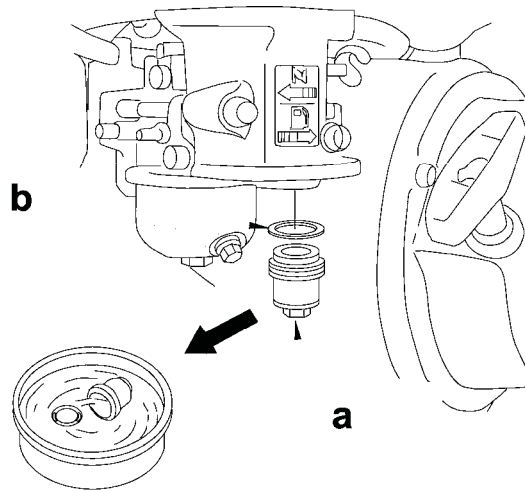

**Graphic 8**

## 5.7 Storage

If power unit is to be stored for more than 30 days:

- 5.7.1 Change engine oil and follow procedures described in engine manual for engine storage.
- 5.7.2 Clean entire power unit and engine.
- 5.7.3 Cover entire machine and store in a clean, dry area.

## 5.8 Troubleshooting

<b>Problem / Symptom</b>	<b>Reason / Remedy</b>
Power unit does not develop full speed	<ul style="list-style-type: none"><li>• Deposits built up in engine.</li><li>• Misaligned sheave and hub shaft.</li><li>• V-belt tension needs readjustment.</li><li>• Clean or replace air filter.</li></ul>

Engine runs; power unit operates erratically	• Head or flex-shaft may be damaged. • Flex-shaft may be too long. • Check clutch wear.
Engine does not run, or engine runs erratically	• Check fuel level. • Check spark plug. • Clean air filter. • Adjust carburetor.