

OWNER'S MANUAL

Model: PLG-42 (5301530)

(42" Tow-Behind Plug Aerator)

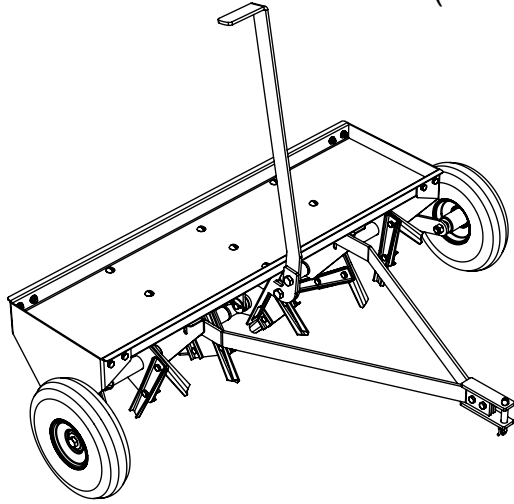

**BEFORE RETURNING THIS PRODUCT
FOR ANY REASON, PLEASE CALL**

1-800-831-0027

**IF YOU SHOULD HAVE A QUESTION OR
EXPERIENCE A PROBLEM WITH YOUR
FIMCO INDUSTRIES PRODUCT:**

1-800-831-0027

**BEFORE YOU CALL, PLEASE HAVE THE
FOLLOWING INFORMATION AVAILABLE:
SALES RECEIPT & MODEL NUMBER. IN MOST
CASES, A FIMCO INDUSTRIES EMPLOYEE CAN
RESOLVE THE PROBLEM OVER THE PHONE.**

General Information

Thank you for purchasing this product. The purpose of this manual is to assist you in operating and maintaining your plug aerator. Please read it carefully, as it furnishes information which will help you achieve years of trouble-free operation.

Warranty/Parts/Service

Products are warranted for one year from date of purchase against manufacturer or workmanship defects.

Commercial users have a 90 day warranty.

Your authorized dealer is the best source of replacement parts and service. To obtain prompt, efficient service, always remember to give the following information...

- Correct Part Description and/or part number.
- Model number/Serial number of your sprayer.

Part descriptions and part numbers can be obtained from the illustrated parts list section(s) of this manual.

Whenever you need parts or repair service, contact your distributor/dealer first. For warranty work, always take your original sales slip, or other evidence of purchase date, to your distributor/dealer.

Assembly

Your plug aerator has been mostly assembled at the factory for your convenience. See page 2 for detailed pictures. It has been packaged "inverted" in the box. Remove the parts to the unit from the carton. Refer to the exploded view and parts list to help identify the parts. Place the main frame on a flat surface, leaving the unit "inverted". This will be the best position for the tongue attachment procedure.

Tongue Attachment:

1. The tongue bars will be located under the inverted unit.
2. Remove the locknuts, bolts and the clevis hitch from the parts bag.
3. Illustrated steps 1 & 2 show the tongue bars bolted to the hitch clevis.
4. Step 3 shows hardware orientation at mounting location to unit (Typ. both sides). The flatwashers should go up against the slot of the center plate.
5. Bolt the tongue to the main unit. (Step 4).

Handle Attachment:

Bolt handle to the handle mount plate, using (2) 1/2" x 1" bolts & (2) 1/2" locknuts.

Operation

Aerating produces holes in the ground that allows water, fertilizer, and air to permeate the soil and reach the roots. It is recommended that the lawn be mowed and clippings removed prior to aerating. Water the ground as necessary. This will soften up the soil for the aerator to penetrate the ground easier.

Your plug aerator should be attached to your rider or tractor on a level surface and the wheels should be in the lowered position. (handle in the locked position)

Once you are ready to use your aerator, use a low gear and then disengage the wheels by moving the handle out of the locked position. Once you start moving, the tines will be forced into the ground. Speed should only be increased only as ground conditions permit. Aeration should be done in a straight line.

Caution

Do not turn sharply, as this may damage the ground. The top tray provides a place for you to put weights. More weight will allow the tines to penetrate the ground deeper. Maximum weight is approx. 175 lbs.. Do not pull your aerator over hard surfaces with the wheels disengaged! This will damage the tines.



www.fimcoindustries.com

1000 FIMCO Lane, P.O. Box 1700, North Sioux City, SD 57049
Toll Free Phone: 800-831-0027 : Toll Free Fax: 800-494-0440

Form No. 1231 [5004756 (02/10)] Printed in the U.S.A.

4 Easy Steps to Attach Tongue to Unit

Step 1



Tongue Whiz Nuts Removed

Step 2



Tongue Assembled to Hitch Clevis

Step 3

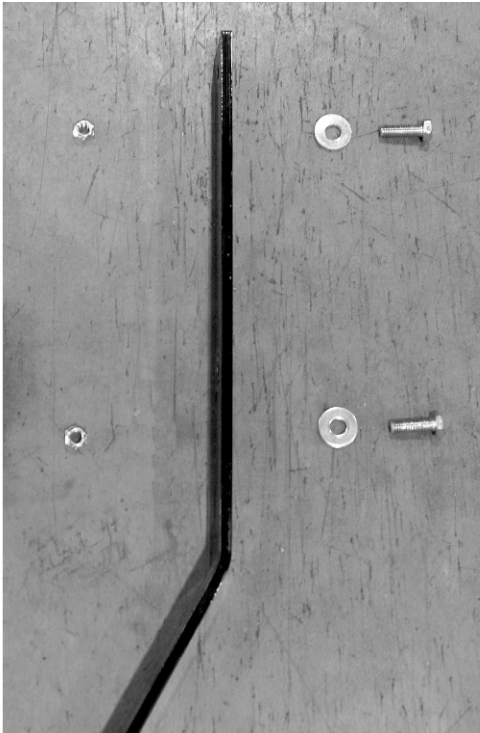

Mounting Hardware Orientation

Step 4



Tongue Getting Assembled to Unit

Exploded View/Parts List
 Model: PLG-42
 (5301530)

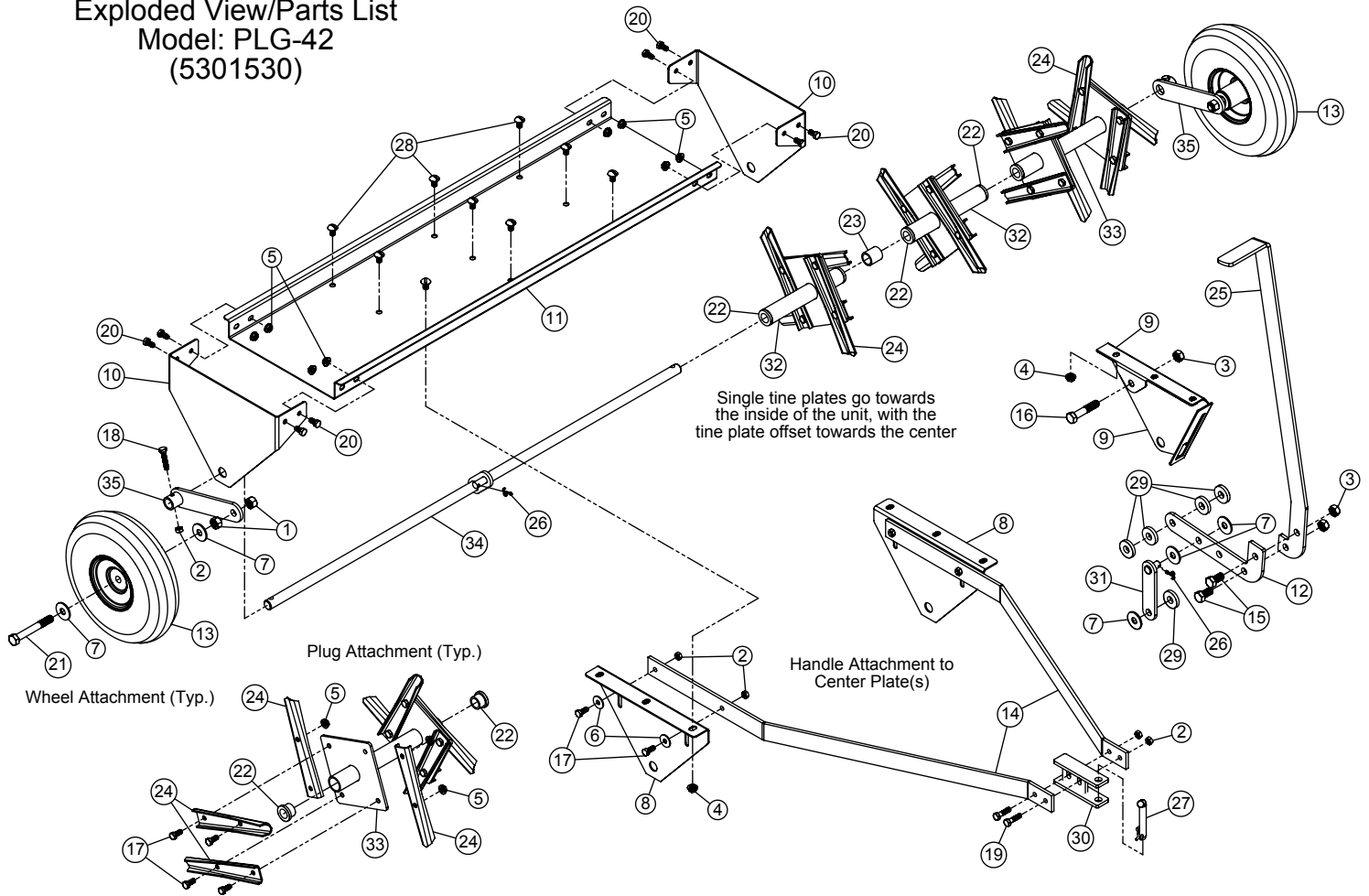

Item No.	Part Number	Qty	Description	List Price
1	5006011	4	1/2"-13 Hex Nut	.25
2	5006035	8	5/16"-18 Hex Locknut	.50
3	5006091	3	1/2"-13 Hex Locknut	.25
4	5006259	9	3/8"-16 Hex Whiz (Flange) Locknut	.25
5	5006307	32	5/16"-18 Hex Whiz (Flange) Locknut	.25
6	5016020	4	Flatwasher, 5/16"	.25
7	5016031	7	Flatwasher, 1/2"	.25
8	5017973	2	Center Plate	3.50
9	5017974	1	Center Lock Plate	3.50
10	5017975	2	End Plate	2.95
11	5017976	1	Top Plate	18.59
12	5017977	1	Handle Mount Plate	4.20
13	5021030	2	4.10/3.50 x 4" Wheel (White) w/2 1/4" Offset Hub	16.26
14	5028309	2	Tongue Bar Half	5.41
15	5034018	2	H.H.C.S., 1/2"-13 x 1"	.40
16	5034036	1	H.H.C.S., 1/2"-13 x 2 1/2"	.65
17	5034038	28	H.H.C.S., 5/16"-18 x 3/4"	.55
18	5034069	2	H.H.C.S., 5/16"-18 x 1 1/2" (Full Thread)	.25
19	5034076	2	H.H.C.S., 5/16"-18 x 1 1/4"	.25
20	5034154	8	H.H.C.S., 5/16"-18 x 5/8"	.25
21	5034569	2	H.H.C.S., 1/2"-13 x 3 3/4"	
22	5041156	8	Bronze Bushing	2.70
23	5041157	1	Take-Up Bushing	1.00
24	5069004	24	Short Tine	.65
25	5078202	1	Aerator Handle	10.71
26	5101077	2	Cotter Pin, 1/8" x 1"	.25
27	5101202	1	Bent Clevis Pin (1/2" Dia.)	2.07
28	5117311	9	3/8"-16 Slotted Round Head Machine Screw x 5/8"	1.00
29	5127188	5	Handle Spacer	.91
30	5275285	1	Bolt-On Hitch Weldment	4.70
31	5275432	1	Link-to-Clevis Pin Weldment	5.25
32	5275470	2	Inside Tine Plate Weldment	6.97
33	5275471	2	Outside Tine Plate Weldment	11.91
34	5275472	1	Axle Shaft-to-Pivot Link Weldment	19.99
35	5275473	2	Wheel Mount Weldment	8.50

(List Prices are Subject to Change)