



## ROTATING HYDRO-EXCAVATION NOZZLE



**DIG FASTER.  
SAVE WATER.**

**PERFORMANCE** – Complete jobs faster with more runtime and less downtime. The RIPSAW blasts a 0° straight water stream at up to 3200 PSI while rotating at a high speed to provide an 18° cone of coverage. The cone-shaped flow pattern is ideally suited for potholing applications.

**DURABILITY** – These heavy duty, high impact nozzles are constructed with a stainless steel housing and tungsten carbide wear surfaces to withstand harsh environments and provide longer life than ceramic nozzles. Repair kits are also available for extended life and lower operating costs.

**SAFETY** – Non-conductive urethane coating on the nozzle body protects users from electrocution.

**EFFICIENCY** – Greater impingement allows you to use a smaller nozzle size while getting the same impact as nozzles with higher GPM flow rates.





# ROTATING HYDRO-EXCAVATION NOZZLE

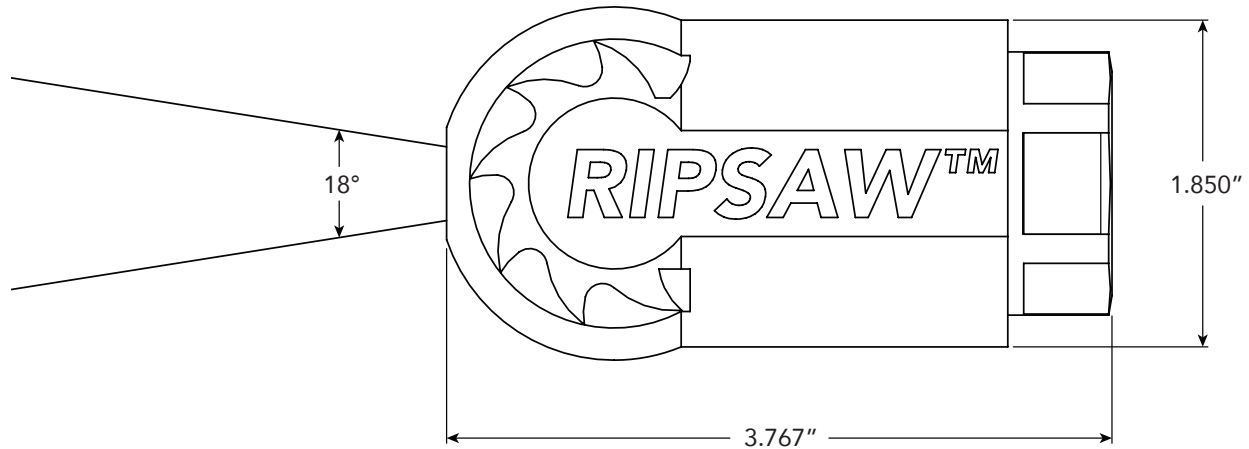

NOZZLE SIZE	NOZZLE PART NUMBER	REPAIR KIT PART NUMBER	FLOW RATE CHART (GPM)					
			@ 1000 PSI	@ 1500 PSI	@ 2000 PSI	@ 2500 PSI	@ 3000 PSI	@ 3200 PSI
6.0	1001857-060	1001858-060	3.0 GPM	3.7 GPM	4.2 GPM	4.7 GPM	5.2 GPM	5.4 GPM
8.0	1001857-080	1001858-080	4.0 GPM	4.9 GPM	5.7 GPM	6.3 GPM	6.9 GPM	7.2 GPM
10.0	1001857-100	1001858-100	5.0 GPM	6.1 GPM	7.1 GPM	7.9 GPM	8.7 GPM	8.9 GPM

SPECIFICATIONS:	REPAIR KIT INCLUDES:
<p>Minimum Inlet Pressure: 1,000 PSI (69 Bar)</p> <p>Maximum Inlet Pressure: 3,200 PSI (220 Bar)</p> <p>Maximum Water Temperature: 180°F (+82°C)</p> <p>Housing Material: Stainless Steel</p> <p>Coating Material: Urethane</p> <p>Nozzle Tip Material: Tungsten Carbide</p> <p>Inlet Connection Thread: 1/2" NPT</p>	

