

5301348
MODEL NO. UTL60-12VBL
60 Gallon 12 Volt Skid Mounted Utility Sprayer
ASSEMBLY / OPERATION INSTRUCTIONS / PARTS

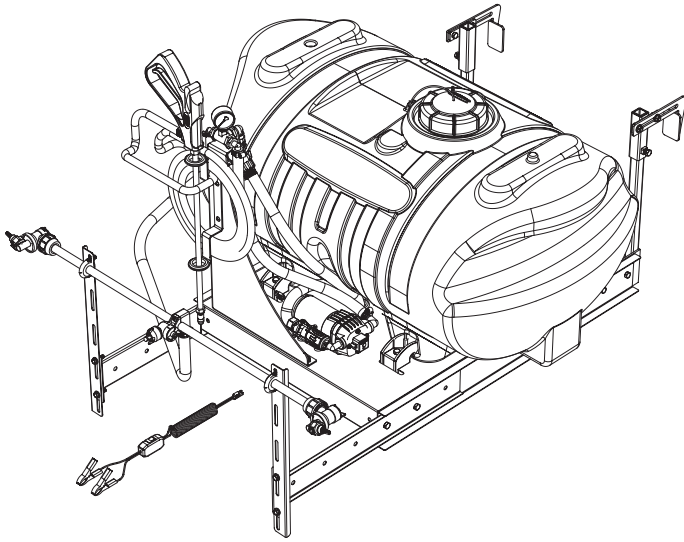

GENERAL INFORMATION

The purpose of this manual is to assist you in operating your sprayer. Please read it carefully as it furnishes information which will help you operate and maintain your sprayer.

WARRANTY / PARTS / SERVICE

Products are warranted for one year from date of purchase against manufacturer or workmanship defects.

Your authorized dealer is the best source of replacement parts and service. To obtain prompt, efficient service, always remember to give the following information.

1. Correct part description and part number.
2. Model number of your sprayer.
3. Serial number of your sprayer.

Part number and descriptions can be obtained from the illustrated parts list section of this manual. Whenever you need parts or repair service, contact your distributor / dealer first. For warranty work always take your original sales slip, or other evidence of purchase date, to your distributor / dealer.

TECHNICAL SPECIFICATIONS

- 60 Gallon Polyethylene Tank
- 12 Volt Diaphragm Pump - 3.8 G.P.M.
- Adjustable Pressure Range 0 - 45 P.S.I.
- 25 Foot Handgun Hose
- Pistol Grip Handgun
- Suction Line Filter

ASSEMBLY

The sprayer is fully assembled at the factory. The only assembly necessary is to thread the pressure gauge in place, and to hook up the wiring to an existing 12 volt power source. The red wire of the two wire set must be connected to the positive post on the battery or the "Hot" connection on a switch or to the ammeter. The brown wire may be grounded or connected to the negative battery post. Install all parts of the boom assembly to the boom brackets as shown in the exploded view drawing.

The in-line switch turns the unit on and off. Running the pump dry will not harm the pump for short periods of time. Read the operating instructions and then run the sprayer using only water for testing. When everything tests all right, add the desired chemical mixture and water combination and start the spraying operation.

OPERATION

Always fill the tank with a desired amount of water first, and then add the chemical slowly mixing as you pour the chemical into the tank. You may use the handgun to spray into the solution in order to mix the chemical and water.

Initially begin spraying by opening the handgun. This will enable the air in the line to be eliminated through the tip, while building pressure.

The pumping system draws solution from the tank, through the strainer, and to the pump. The pump forces the solution under pressure to the handgun or boom nozzles.

Pressure may be decreased by opening the bypass valve to the tank. When it is closed the highest spraying pressure will be reached.



WWW.FIMCOINDUSTRIES.COM

1000 FIMCO LANE • P.O. BOX 1700 • NO. SIOUX CITY, SD 57049
TOLL FREE: 800-831-0027 • TOLL FREE FAX: 800-494-0440
Form No. 879 (5004676 2/06) Printed In U.S.A.

- Open the handgun by squeezing the handle lever
- Rotating the adjustable nozzle tip on the handgun will change the tip from a straight stream to a cone pattern (finer mist). Be sure the thumb nut on the adjustment nozzle is tight.
- The pump motor's demand switch shuts off the motor when the handgun, bypass valve and boom lines are fully closed. The system remains pressurized, and the pump motor will restart automatically when the handgun or boom line is opened. If however, the bypass line is open, the pump will not shut off automatically.
- The 3 nozzles are fixed on 17 1/2" spacing.
- All three nozzles spraying at the same time will allow a maximum coverage of 30 ft. Overlapping of the ends of the spray pattern will not be needed.
- The center nozzle will cover a 80" swath.
- Each of the three nozzles has a means of shutting down, so you may choose the coverage that is needed.

When it becomes necessary to clean the screen in the suction line, remove the screen from the bottom of the suction tube. Reach into the tank through the fill opening, slide the tube to one side and slip the screen from the bottom of the tube. The screen may now be tapped or flushed with clear water for cleaning.

WARNING: Some chemicals will damage the pump valves if allowed to soak untreated for a length of time. Always flush the pump with water after use. Do not allow chemicals to sit in pump for extended times if idleness. Follow chemical manufacturers instructions on disposal of all waste water from the sprayer.

ADJUSTING PRESSURE

- When the bypass valve is closed, pressure is at the highest point.
- Opening the valve will decrease pressure.

USING THE BOOM NOZZLES

- Four things must be considered before spraying with the boom.
 1. How much chemical must be mixed in the tank.
 2. Rate of spray (gallons per acre to be sprayed).
 3. What pressure (P.S.I.) will be used.
 4. Speed traveled (M.P.H.) while spraying.
- Refer to the chemical label to determine the chemical mixture.
- See the tip chart to determine the pressure to be used. The chart will also show the speed used when spraying.
- Start the pump and open the "Y" valve to the boom nozzles.
- Check the spray pattern. Usually you can see the coverage better on solid concrete surface, such as a driveway.
- The boomless nozzles should be 33" above the objects being sprayed.

End Nozzle Information (#5275122)

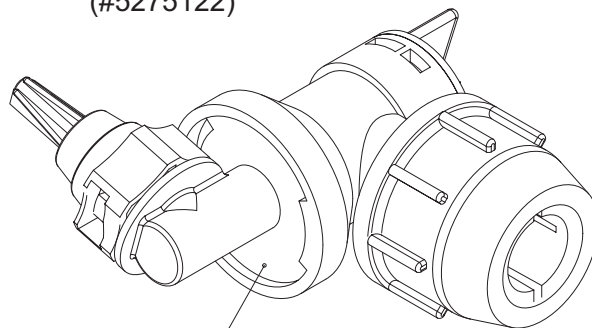

This nozzle mounting stem has a ratcheting motion.

**** Each "click" of the ratcheting motion is approx. 15° ****

For proper/optimal spray coverage, the nozzle must be at a 15° angle

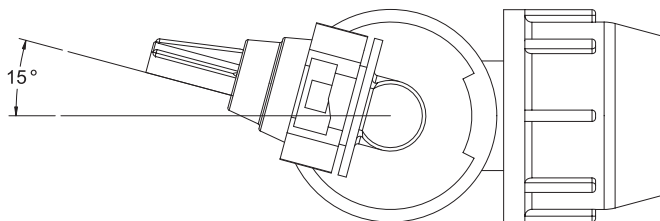

The 15° angle shown will prevent the outer nozzles from overlapping with the center nozzle.

Rate Chart for Boomless Nozzle (Set of 3)

Gallons per Acre Based on Water - 17 1/2" Spacing								
Note: The same figures are used for 1, 2, or 3 nozzles.								
Pressure P.S.I.	Capacity G.P.M. (for 3 Nozzles)	1 MPH	2 MPH	3 MPH	4 MPH	5 MPH	6 MPH	8 MPH
20	1.68	28.0	14.0	9.4	7.0	5.6	4.7	3.5
30	2.05	34.4	17.2	11.4	8.6	6.9	5.7	4.3
40	2.40	39.6	19.8	13.2	9.9	7.9	6.6	5.0

Gallons per 1000 Sq. Ft. Based on Water - 17 1/2" Spacing								
Pressure P.S.I.	Capacity G.P.M. (for 3 Nozzles)	1 MPH	2 MPH	3 MPH	4 MPH	5 MPH	6 MPH	8 MPH
20	1.68	0.64	0.32	0.21	0.16	0.13	0.11	0.08
30	2.05	0.78	0.39	0.26	0.20	0.16	0.13	0.10
40	2.40	0.90	0.45	0.30	0.23	0.18	0.15	0.12

Gallons per 100 Sq. Ft. Based on Water - 17 1/2" Spacing								
Pressure P.S.I.	Capacity G.P.M. (for 3 Nozzles)	1 MPH	2 MPH	3 MPH	4 MPH	5 MPH	6 MPH	8 MPH
20	1.68	0.064	0.032	0.021	0.016	0.013	0.011	0.008
30	2.05	0.078	0.039	0.026	0.020	0.016	0.013	0.010
40	2.40	0.090	0.045	0.030	0.023	0.018	0.015	0.012

MPH = Miles Per Hour / FPM = Feet Per Minute / PSI = Pounds Per Square Inch / GPM = Gallons Per Minute

**** The rate of spray as shown in the chart will remain the same with 1, 2, or 3 Nozzles. ****
The only difference will be with the width of the spray swath.

CALIBRATION

Chemical labels may show application rates in gallons per acre, gallons per 1000 square feet, or gallons per 100 square feet. You will note that the tip chart above shows all three of these rating systems.

Once you know how much you are going to spray then determine (from the tip chart) the spraying pressure (PSI), and the spraying speed (MPH).

Conditions of weather and terrain must be considered when setting the sprayer. Do not spray on windy days. Protective clothing must be worn in some cases. **Be sure to read the chemical label carefully.**

If the vehicle does not have a speedometer, determining the proper speed of the tractor can be done by marking off 100, 200 and 300 feet. The speed chart indicates the number of seconds it takes to travel the distances. Using a watch or stop watch for time, set the throttle and with a running start travel the distances. Adjust the throttle until you travel the distances in the number of seconds indicated by the speed chart. Once you have reached the throttle setting needed, mark the throttle location so you can stop and go again (returning to the same speed).

Speed Chart

Speed in M.P.H. (Miles Per Hour)	Time Required in Seconds to Travel a distance of;		
	100 ft.	200 ft.	300 ft.
1.0	68	136	205
2.0	34	68	102
3.0	23	45	68
4.0	17	34	51
5.0	14	27	41
6.0	11	23	34
7.0	9.7	19	29
8.0	8.5	17	26
9.0	7.6	15	23
10	6.8	14	20

Add water to the tank and drive to the starting place for spraying. When you are ready to spray, turn the boom valve to the "on" position. This will start solution spraying from the tips. The pressure will decrease slightly when the boom is spraying. Adjust the spraying pressure by operating the bypass valve.

After testing, add water and chemical to the tank. Adjust the pressure and spray as you did in the testing procedure.

AFTER SPRAYING

After use fill the sprayer part way with water, start the sprayer and allow clear water to be pumped through the plumbing system and out through the spray nozzles.

Refill the tank about half full with plain water and use a chemical neutralizer such as Nutra-Sol or equivalent and repeat cleaning instructions above. Flush the entire sprayer with the neutralizing agent. Follow the chemical manufacturers disposal instructions of all wash or rinsing water.

Remove tips from the boom. Wash tips thoroughly with water or cleaning solution (appropriate for chemical used). Blow out orifice, clean and dry. If orifice remains clogged, clean it with a fine bristle (not wire) brush, or with a toothpick. Do not damage the orifice. Water rinse and dry tips before storing.

WINTER STORAGE

Drain all water out of sprayer paying special attention to pump, handgun & valve. These items are especially prone to damage from chemicals and freezing weather.

The sprayer should be winterized before storage by pumping a solution of RV anti-freeze through the entire plumbing. Proper care and maintenance will prolong the life of the sprayer.

Repair Parts List
Model No. 5275017 Pump

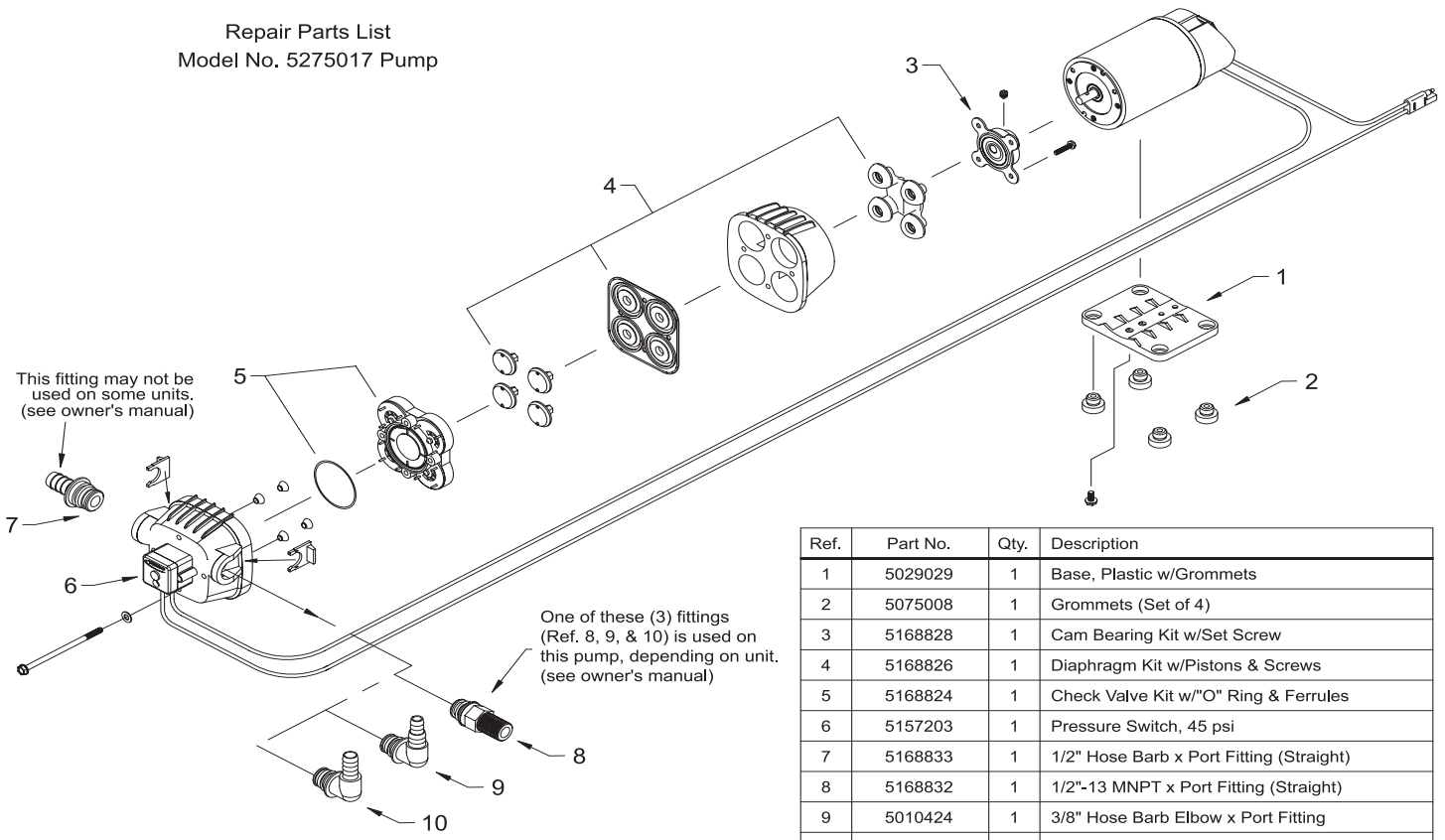

Ref.	Part No.	Qty.	Description
1	5029029	1	Base, Plastic w/Grommets
2	5075008	1	Grommets (Set of 4)
3	5168828	1	Cam Bearing Kit w/Set Screw
4	5168826	1	Diaphragm Kit w/Pistons & Screws
5	5168824	1	Check Valve Kit w/"O" Ring & Ferrules
6	5157203	1	Pressure Switch, 45 psi
7	5168833	1	1/2" Hose Barb x Port Fitting (Straight)
8	5168832	1	1/2"-13 MNPT x Port Fitting (Straight)
9	5010424	1	3/8" Hose Barb Elbow x Port Fitting
10	5010426	1	1/2" Hose Barb Elbow x Port Fitting

Pump Sub-Assembly
#5274808

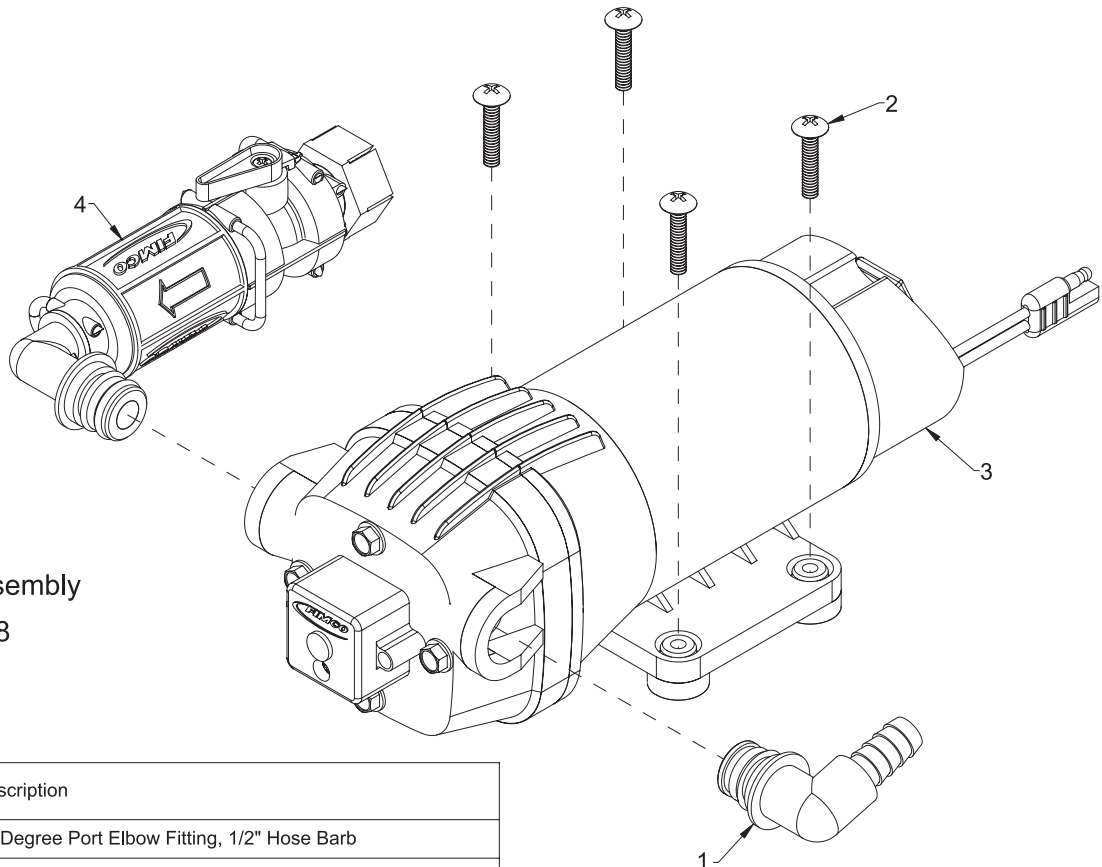

Item No.	Part Number	Qty.	Description
1	5010426	1	90 Degree Port Elbow Fitting, 1/2" Hose Barb
2	5117168	4	#10-24 x 1" Phillips Truss Head Machine Screw
3	5275017	1	"Quad" Pump - 12V, 4-Piston, 3.8 G.P.M.
4	5275070	1	FIMCO Filter/Valve Assembly w/1/2" HB x 1/2" Port Fitting

Valve Mount Sub-Assembly
#5275405

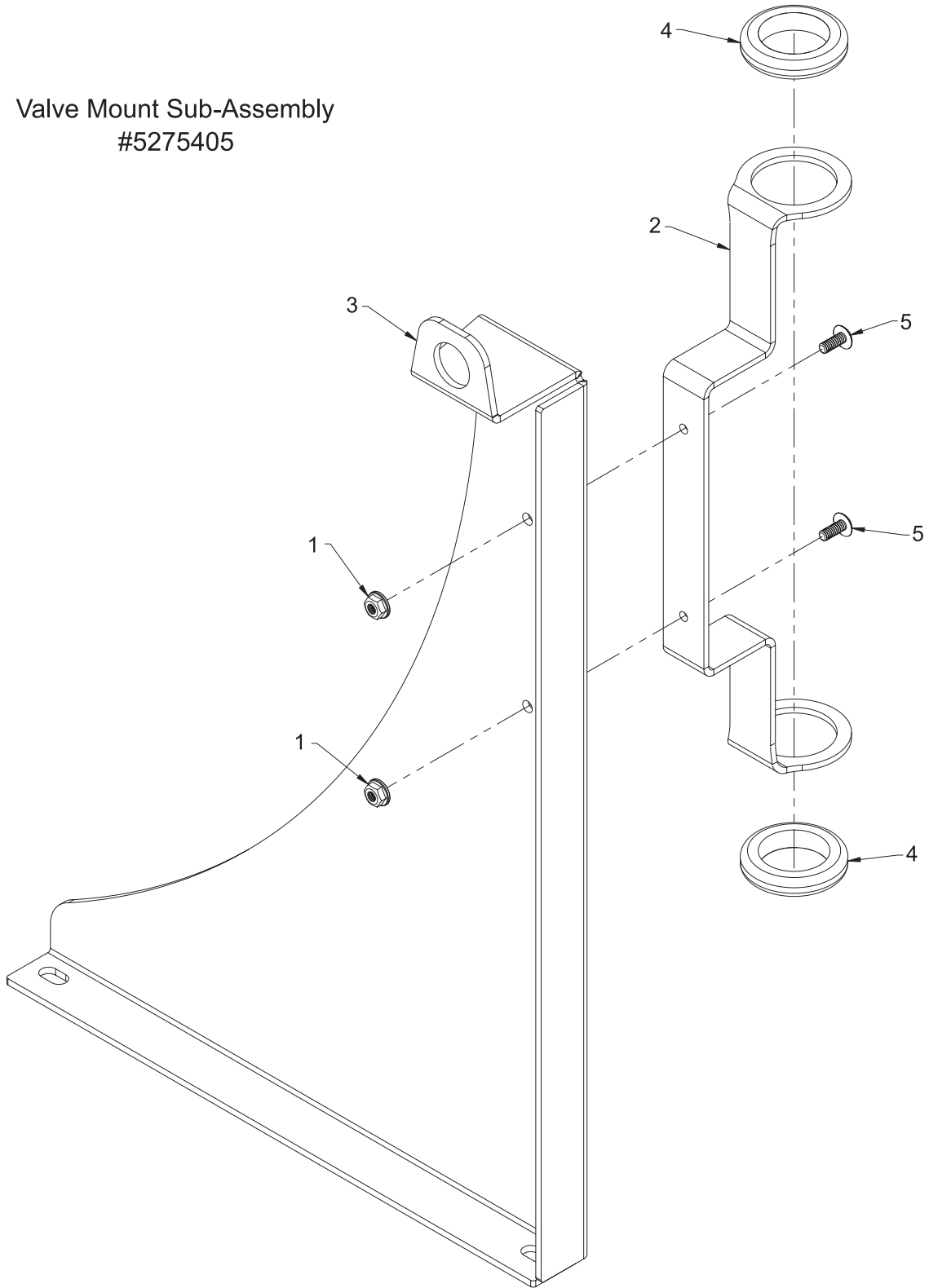

Item No.	Part Number	Qty	Description
1	5006186	2	#10-24 Hex Whiz (Flange) Locknut
2	5038638	1	Handgun Holder Bracket
3	5038704	1	Valve Mount Bracket
4	5075014	2	Rubber Grommet (Black)
5	5117234	2	#10-24 x 1/2" Phillips Truss Head Machine Screw

Exploded View/Parts List for Valve Sub-Assembly #5274806

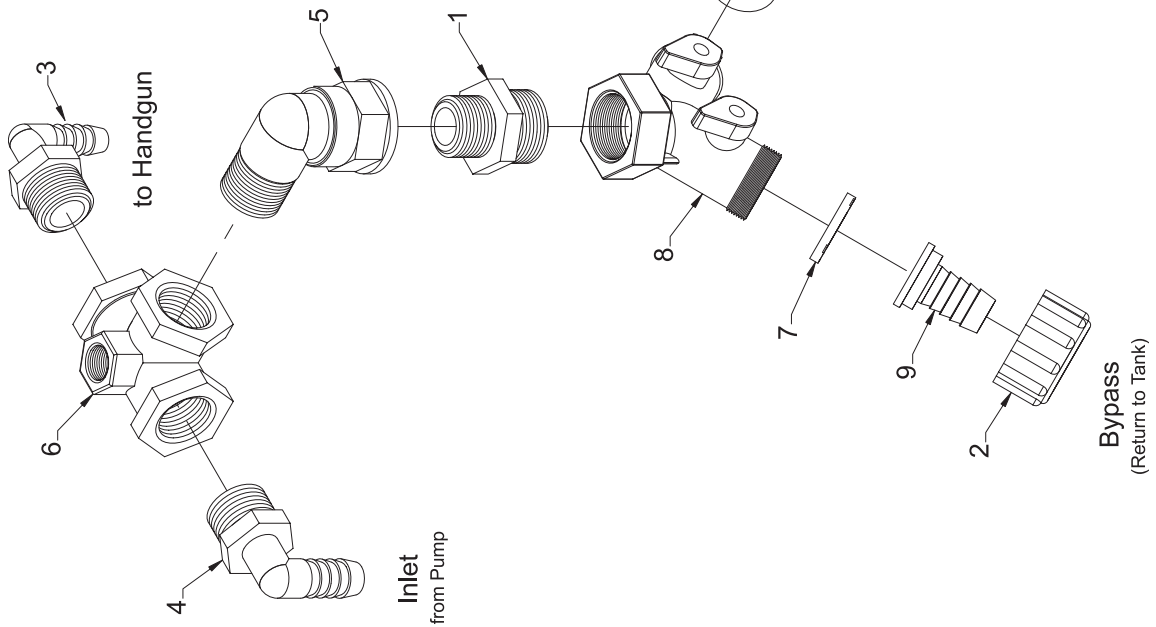

ITEM NO.	PART NUMBER	QTY.	DESCRIPTION
1	5005021	1	Nylon Adapter, 1/2" MNPT x 3/4" MGHT
2	5006055	2	Nylon Knurled Swivel Nut, 3/4" FGHT
3	5010038	1	Nylon Elbow, 1/2" MNPT x 3/8" HB
4	5010039	1	Nylon Elbow, 1/2" MNPT x 1/2" HB
5	5010148	1	90 Degree Nylon Street Elbow, 1/2" MNPT x 1/2" FNPT
6	5010193	1	Nylon Tee, 1/2" FNPT w/1/4" Port (Gauge)
7	5016066	2	#102 Hose Washer (Gasket) 1" O.D. Rubber
8	5143204	1	#235 Dual Hose Shut-Off "Y"-Valve, 3/4" GHT
9	5149011	2	Nylon Swivel, 1/2" Flat Seat Hose Barb

FIMCO Filter/Valve Assembly #5275070

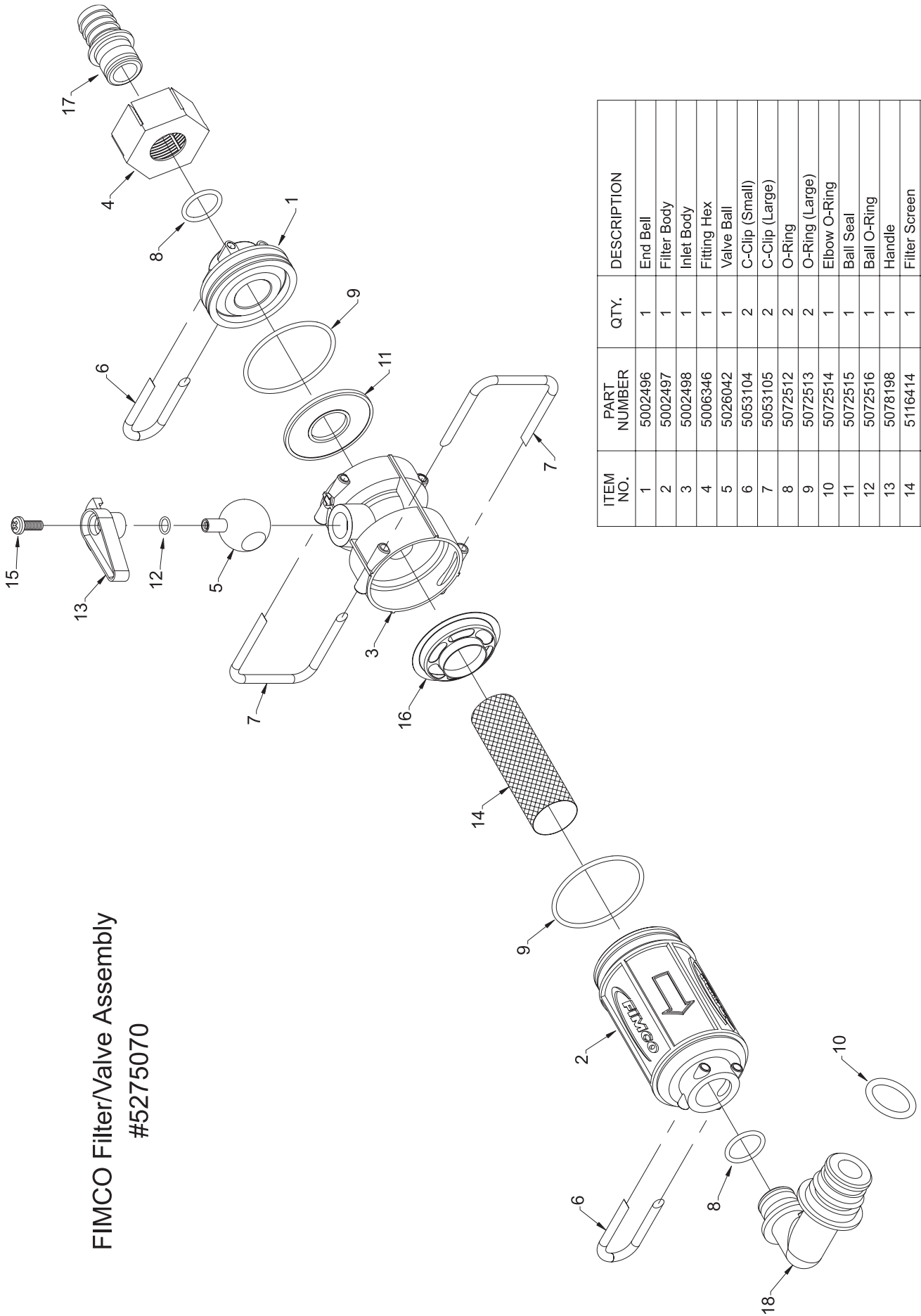

ITEM NO.	PART NUMBER	QTY.	DESCRIPTION
1	5002496	1	End Bell
2	5002497	1	Filter Body
3	5002498	1	Inlet Body
4	5006346	1	Fitting Hex
5	5026042	1	Valve Ball
6	5053104	2	C-Clip (Small)
7	5053105	2	C-Clip (Large)
8	5072512	2	O-Ring
9	5072513	2	O-Ring (Large)
10	5072514	1	Elbow O-Ring
11	5072515	1	Ball Seal
12	5072516	1	Ball O-Ring
13	5078198	1	Handle
14	5116414	1	Filter Screen
15	5117309	1	Handle Screw
16	5143397	1	Diverter
17	5149133	1	Straight Fitting
18	5149134	1	Elbow, O-Ring Port

Exploded View:
UTL60-12VBL

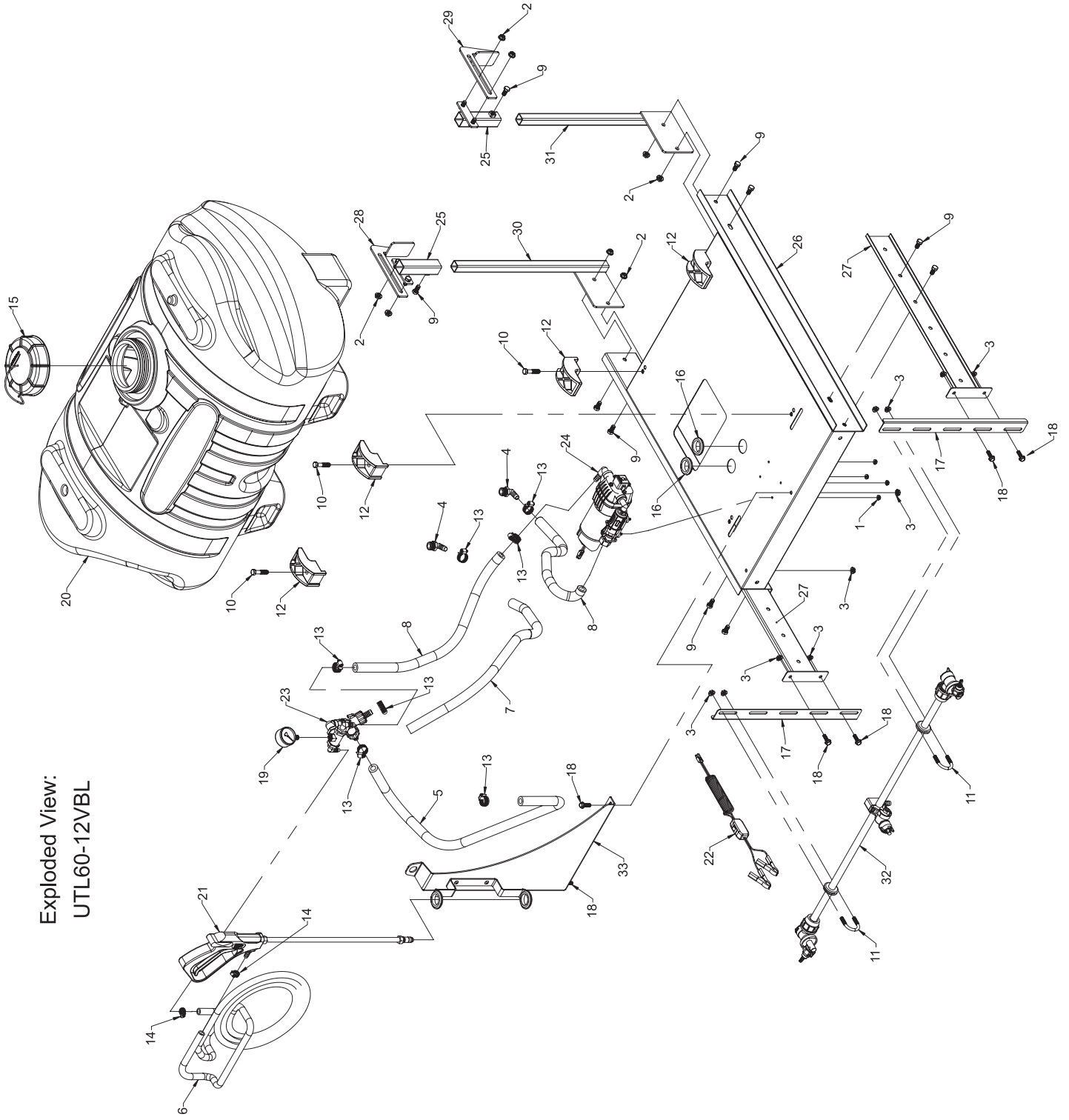

Repair Parts List: UTL60-12VBL

Item No.	Part Number	Qty.	Description
1	5006186	4	#10-24 Hex Whiz (Flange) Locknut
2	5006259	16	3/8"-16 Hex Whiz (Flange) Locknut
3	5006307	10	5/16"-18 Hex Whiz (Flange) Locknut
4	5010039	2	Nylon Elbow, 1/2" MNPT x 1/2" HB
5	5020122	1	Hose, 1/2"-1 Brd. x 48"
6	5020135	1	Hose, 3/8"-1 Brd. x 25 Ft.
7	5020228	1	Hose 1/2"-1 Brd. x 36"
8	5020307	2	Hose, 1/2"-1 Brd. x 23"
9	5034099	10	H.H.C.S., 3/8"-16 x 3/4"
10	5034101	4	H.H.C.S., 3/8"-16 x 1 3/4"
11	5034220	2	Round U-Bolt, 5/16"-18 x 1 5/16" x 1 3/4"
12	5038698	4	Plastic Tank Hold-Down Leg Clip
13	5051022	7	Hose Clamp, 1/2"
14	5051114	2	Hose Clamp, 3/8"
15	5058183	1	FIMCO 5" Threaded Tank Lid w/Lanyard
16	5075014	2	Rubber Grommet (Black)
17	5095176	2	Boom Mount, 40/60 Gallon Utility Sprayer
18	5117300	6	5/16"-18 x 1" Flange Whiz Lock Screw
19	5167007	1	Gauge, 0-100 p.s.i.
20	5169209	1	60 Gallon Elliptical Tank (White)
21	5273959	1	Handgun w/X-26 Tip
22	5274443	1	Lead Wire Assembly (w/Switch), 96"
23	5274806	1	Valve Sub-Assembly
24	5274808	1	Pump Sub-Assembly
25	5274994	2	Slide Tube Weldment
26	5274996	1	40/60 Gallon Utility Sprayer Frame Weldment
27	5274997	2	Boom Mount Bracket Weldment (40/60 Gallon Utility Sprayer)
28	5274998	1	Clamp Arm (L.H.)
29	5274999	1	Clamp Arm (R.H.)
30	5275000	1	Upright Tube Weldment (L.H.)
31	5275001	1	Upright Tube Weldment (R.H.)
32	5275260	1	"Wet Boom" Assembly
33	5275405	1	Valve Mount Sub-Assembly

End Nozzle Assembly (Wet Boom)
#5275122

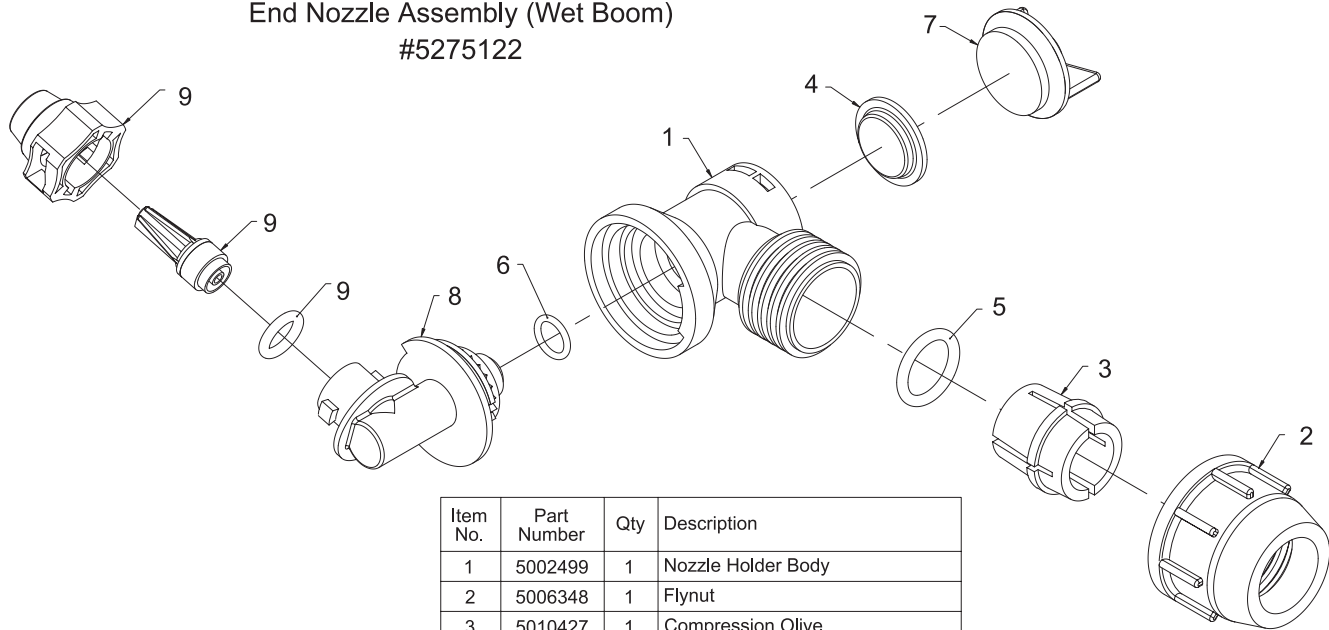

Item No.	Part Number	Qty	Description
1	5002499	1	Nozzle Holder Body
2	5006348	1	Flynut
3	5010427	1	Compression Olive
4	5063255	1	Diaphragm
5	5072517	1	Compression O-Ring
6	5072518	1	Stem O-Ring
7	5088024	1	Yellow Pressure Disc Assembly
8	5132073	1	Nozzle Holder Stem
9	5274861	1	XT Spray Nozzle, Cap, & O-Ring

Center Nozzle Assembly (Wet Boom)
#5275123

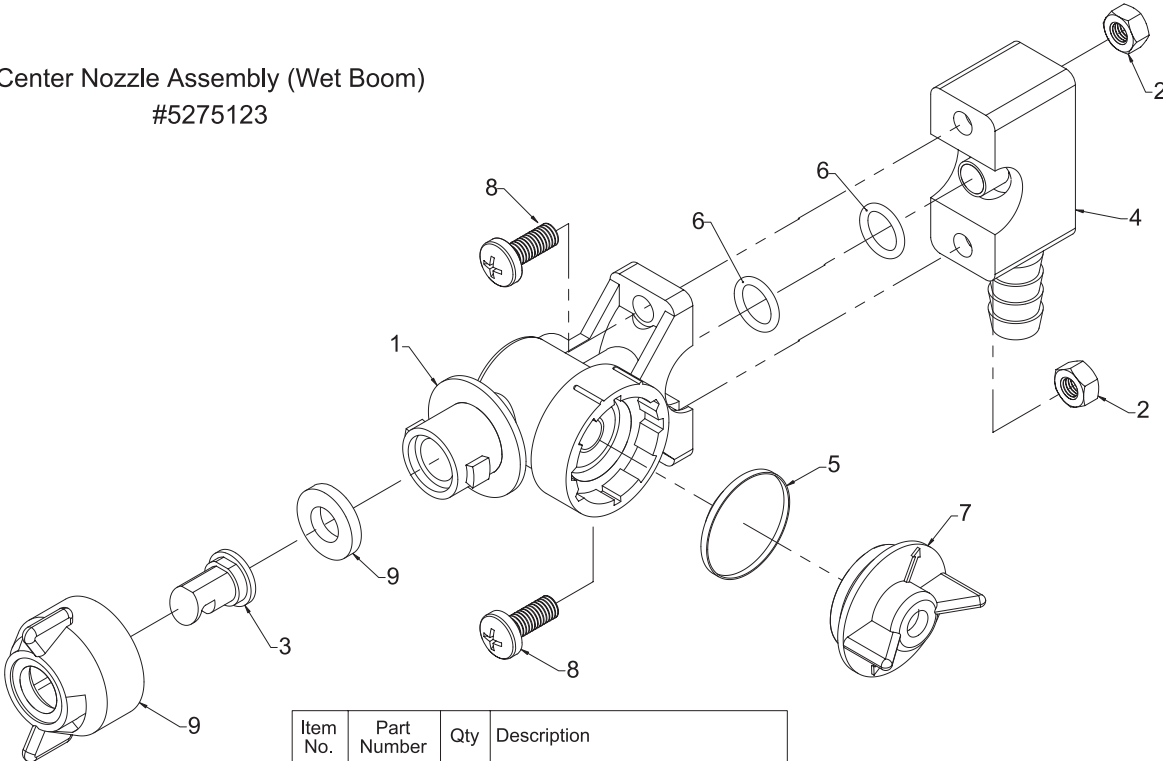

Item No.	Part Number	Qty	Description
1	5002500	1	Body
2	5006347	2	SS Nut, 6mm
3	5018329	1	Red Spray Tip (30 AN 2.4 A)
4	5051137	1	Hose Barb Saddle
5	5063255	1	Diaphragm
6	5072509	2	O-Ring
7	5088024	1	Yellow Pressure Disc Assembly
8	5117310	2	SS Screw, 6mm x 16mm (5/8")
9	5274862	1	Red QuickJet Cap w/Gasket

Wet Boom Assembly
#5275260

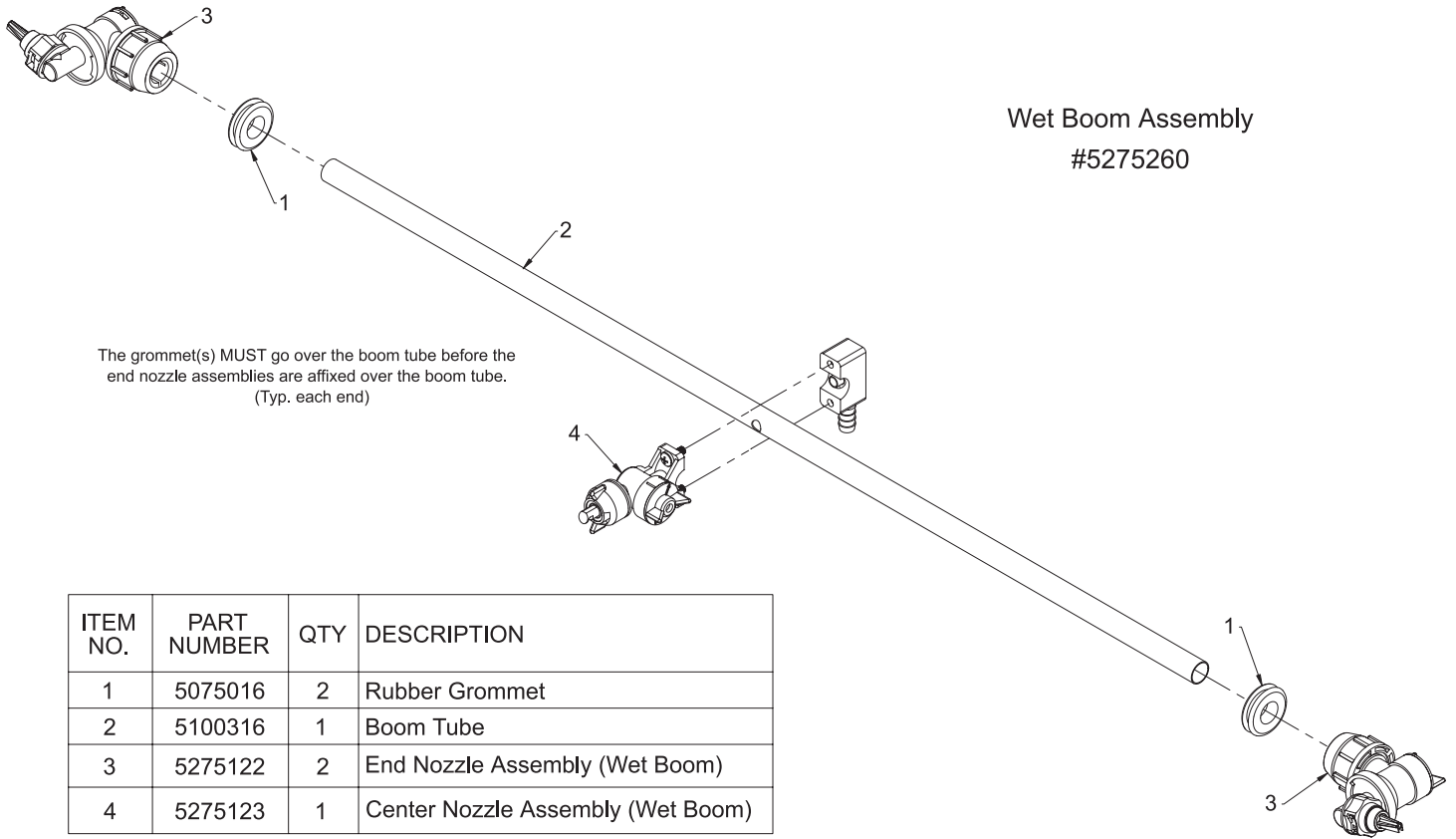

The grommet(s) MUST go over the boom tube before the end nozzle assemblies are affixed over the boom tube.
(Typ. each end)

ITEM NO.	PART NUMBER	QTY	DESCRIPTION
1	5075016	2	Rubber Grommet
2	5100316	1	Boom Tube
3	5275122	2	End Nozzle Assembly (Wet Boom)
4	5275123	1	Center Nozzle Assembly (Wet Boom)

Valve "Open"

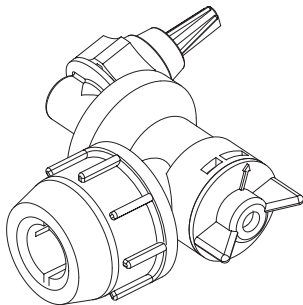

Valve "Closed"

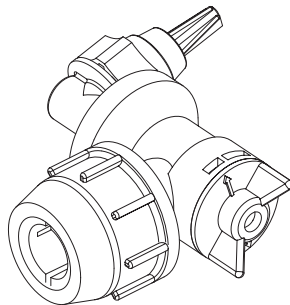

Service Position

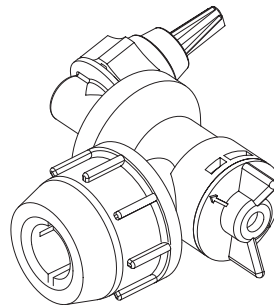

Eliminate line pressure, then pull out to check diaphragm condition.

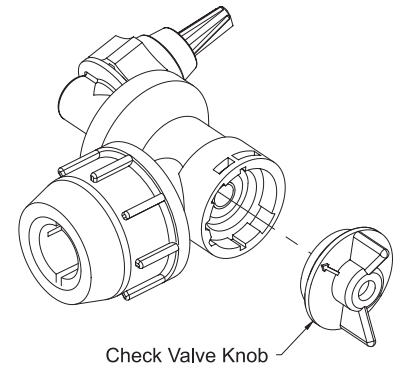

Note: The check valve & diaphragm can fall out during transport, if the knob is not turned to the "ON" or "OFF" position.