

OWNER'S MANUAL

VALOR™ ★EXTREME★







Table of Contents

Work Area Safety.....	5
Electrical Safety.....	5
Personal Safety.....	6
Machine Use & Care.....	6
Service/Repairs.....	6
Drain Cleaner Safety.....	7
Description.....	7
Machine Inspection.....	9
Machine Set Up.....	9
Operating Instructions.....	10
Using Manual Feed Machines.....	10
Using Auto Feed Machines.....	11
Special Procedures.....	12
Reverse Operation.....	12
Removing Drum.....	12
Installing Cable.....	13
Remove Damaged Or Worn Cable.....	13
Installing Replacement Cable.....	13
Maintenance Instructions.....	13
Caring For Cables.....	13
Machine Storage.....	13
Cleaning And Lubricating.....	14
Valor Extreme Full Assembly.....	16
Clutch Assembly.....	17
Drum Assembly.....	18
Motor Assembly.....	19



WARNING

Read this entire safety manual prior to operating the Drincables Direct Valor Extreme. Make sure to understand all instructions and guidelines. Failure to follow instructions listed in the manual may result in electric shock, fire, serious personal injury and/or death.

SAFETY INFORMATION

It is important to know the Drincables Direct Valor Extreme fully prior to operation. Failure to properly operate machine may result in electric shock, serious personal injury and/or death.

WORK AREA SAFETY

Keep work area clean and well-lit at all times. Cluttered and dark work areas can easily cause unnecessary accidents.

Do not operate machinery in the presence of flammable liquids, gases or dust. This machine creates a spark which may ignite in dust or fumes.

Keep children and other bystanders away from work area when machine is in use. Unwanted distractions may occur, resulting in loss of control of machine, causing serious personal injury and/or death.

Drains and sewers can carry bacteria, as well as other infectious micro-organisms or materials which can cause serious illness or death. Avoid exposing eyes, nose, mouth, ears, hands and cuts or abrasions to waste water or other potentially infectious materials during the cleaning process. Wash hands, arms and any other exposed areas with hot, antibacterial soapy water when finished with cleaning process. The use of hand sanitizer is recommended as well. Also, disinfect potentially contaminated areas and equipment.

ELECTRICAL SAFETY

Grounded machines must be plugged into a properly installed and grounded outlet in accordance with all codes and ordinances. Under no circumstance should the grounding prong be removed or the plug modified in any way.

Do not use adapter plugs. Consult a qualified electrician if you are unsure whether an outlet is properly grounded.

Grounding provides a low resistance path to carry electricity away from the user if the machine were to malfunction or break down.

Avoid contact with other grounded surfaces such as pipes, ranges, radiators and refrigerators while operating this machine. Risk of electrical shock is increased when the body is grounded.

Keep machinery out of rain and away from wet conditions. Contact with water increases the risk of electrical shock.

Never use power cord to carry machine or to pull plug out of an outlet. Always keep cord away from heat, oil, sharp edges and other moving parts.

Replace damaged cords immediately. There is an increased risk of electrical shock when using damaged cords.

When using machinery outdoors, use an outdoor extension cord labeled "W-A" or "W". These cords are specifically rated for outdoor use and reduce the risk of electrical shock.

Only three-wire extension cords with three-prong grounding plugs and three-prong receptacles should be used with this machine. The use of other extension cords will not ground machine and increases the risk of electrical shock.

Use proper extension cords when operating this machine (10-3 or 12-3 with ground). Insufficient conductor size causes excessive voltage drop and loss of power to machine. Damage to motor may occur.

Test the Ground Fault Circuit Interrupter (GFCI) provided with cord to insure correct operation before each use. The GFCI reduces the risk of electrical shock from extension cords. Never bypass a GFCI and do not operate machine without a GFCI.

It is not recommended to use extension cords unless they are plugged into a GFCI (found in circuit boxes or outlet receptacles).

All electrical connections should be kept dry at all times and kept off the ground. Do not touch electrical plug with wet hands. Keeping electrical connections dry reduces the risk of electrical shock.

PERSONAL SAFETY

Maintain alertness at all times when operating machinery. Do not use machine when tired or under the influence of medications, drugs or alcohol. Doing so may result in serious personal injury and/or death.

Do not wear loose clothing or jewelry and contain long hair whenever operating machinery. Keeping loose objects, clothing and hair away from moving parts helps to prevent injury.

To avoid accidentally starting machine, insure the power switch is in the **OFF** position and foot switch is free from pressure prior to plugging in. Having fingers too close while carrying, or having switch in the **FOR/REV** position when plugging in, can result in accidents causing serious personal injury and/or death.

Do not remove or alter foot switch. Do not wire motor to bypass foot switch. Serious injury and/or death may occur.

Maintain proper footing and balance at all times when operating machine. This allows for better control of machine in unexpected situations.

Always wear appropriate attire, including but not limited to safety glasses, dust masks, non-skid shoes, hard hat, hearing protections, ect. appropriate for working conditions.

MACHINE USE & CARE

Ensure that machine is secure and supported by a stable platform. Holding machine by hand or against the body is unstable and can lead to loss of control of machinery.

Do not force machine. Use machine only for appropriate applications.

Do not use machine if switch does not turn **ON** or **OFF**. If machine cannot be controlled by the switch, it is dangerous and should be repaired or replaced immediately.

Before making any adjustments, changing accessories, or storing machine, disconnect plug from power source first. This will reduce the risk of accidentally starting machine.

Properly store machine out of the reach of children and untrained users. Machine can be dangerous when operated without the proper training.

Carefully maintain machine by keeping it clean and in working order. A properly maintained machine is less likely to malfunction and is easier to maintain control of.

Check alignment and binding of all moving parts, broken parts and any other conditioning factors that may affect the operation of machine. If machine is damaged in any way, it should be repaired before using again. Poorly maintained machines are dangerous and cause accidents.

Only use accessories recommended by manufacturer for machine model. Not all accessories are suitable for all machines.

Keep handles clean and dry. This allows for better machine control.

SERVICE/REPAIRS

Machine service and repairs should always be performed by a qualified service professional. Maintenance and service performed by unqualified service personnel may result in voiding the warranty, malfunction of machine, serious personal injury and/or death.

When servicing machine, only use replacement parts identical to those being replaced. Carefully follow instructions in the maintenance portion of this manual. The use of unauthorized parts or failure to follow maintenance instructions creates the risk of voiding the warranty, electrical shock, serious personal injury and/or death.

WARNING

Read this entire operator's manual before using the Drainables Direct Valor Extreme. Failure to understand and comply with the contents of this manual may result in electrical shock, fire, serious personal injury and/or death.

SPECIFIC SAFETY INFORMATION

DRAIN CLEANER SAFETY

Wear gloves at all times while operating machinery. Never grip a rotating cable with cloth or loose-fitting cloth gloves. Cloth or loose gloves may get caught in rotating cable and cause serious personal injury and/or death.

Do not over-stress the cables. Keep both hands on the cable or guide tube to maintain control while machine is running. Over-stressing cables can cause twisting, breaking or kinking of the cable and cause serious personal injury and/or death.

Position machine within two feet of inlet. Longer distances can result in twisting or kinking.

Only one person at a time should operate machine. Operator must maintain control of foot switch and cable. Machine is not meant for more than one operator.

While maintaining proper footing and balance, use foot switch to operate machine. Do not operate machine in reverse (**REV**). Operating machine in reverse can cause cable damage and should only be briefly used when backing machine out of the area of obstruction.

Do not reach into drum unless the machine is unplugged. Getting hands caught in moving or rotating parts can cause serious personal injury and/or death.

Be cautious of cleaning drains where cleaning compounds have been in use. Wear eye protection and avoid contact with skin. Some drain cleaning compounds can cause serious burns to skin as well as vision loss and/or damage.

Do not operate the Drincables Direct Valor Extreme if the operator and/or machine is located in standing water. Standing water increases the risk of electrical shock and serious personal injury and/or death.

Wear rubber soled, non-slip, full-toed shoes or work boots (with steel toe) when operating machine.

Only use the Drincables Direct Valor Extreme to clean drain lines from 3" to 6" in diameter.

Follow all instructions on use of machine found in this manual. Other uses, or modifying the use of this machine for other applications will increase the risk of serious personal injury and/or death.

LEARN ENTIRE OPERATION, APPLICATIONS & LIMITATIONS OF MACHINE PRIOR TO USE.

DESCRIPTION

The Drincables Direct Valor Extreme will clean drain lines from 3" to 6" in diameter and up to 125ft in length. Drum provided with machine holds up to 100ft of 5/8" and 125ft at .55 cable. The drum includes an inner-drum that will guard against cable flip-over. The Drincables Direct Valor Extreme is designed to clean floor drains, roof vents, and mainline cleanouts.

The Drincables Direct Valor Extreme drum is driven by a 2/5 HP permanent magnet motor that contains a grounded electrical system. A Ground Fault Circuit Interrupter (GFCI) is built into the line cord and a foot switch for ON/OFF control of the motor.

The cable to the Drincables Direct Valor Extreme can be manually fed in and out of drains. There is an included auto-feed accessory to advance or retract the cable. The Drincables Direct Valor Extreme can be operated upright or on it's back, providing the proper angle for cable feed.

SPECIFICATIONS

- Type: 115V/50-60Hz, Reversible
- Rating: 2/5 HP
- Amps: 4.5
- Weight: (Machine Only): 109lbs
- Length: 29" Deep
- Height: 32" (Handle Collapsed)
39" (Handle extended)
- Width: 20" Wide

WARNING

In order to prevent serious personal injury and/or death, the Drincables Direct Valor Extreme is Designed to be operated as a fully assembled machine. The machine will be shipped fully assembled. The handle may be safely placed at any height to operate machine.

Call the experienced Drincables Direct team with any questions you may have: 833.SHOP.DCD

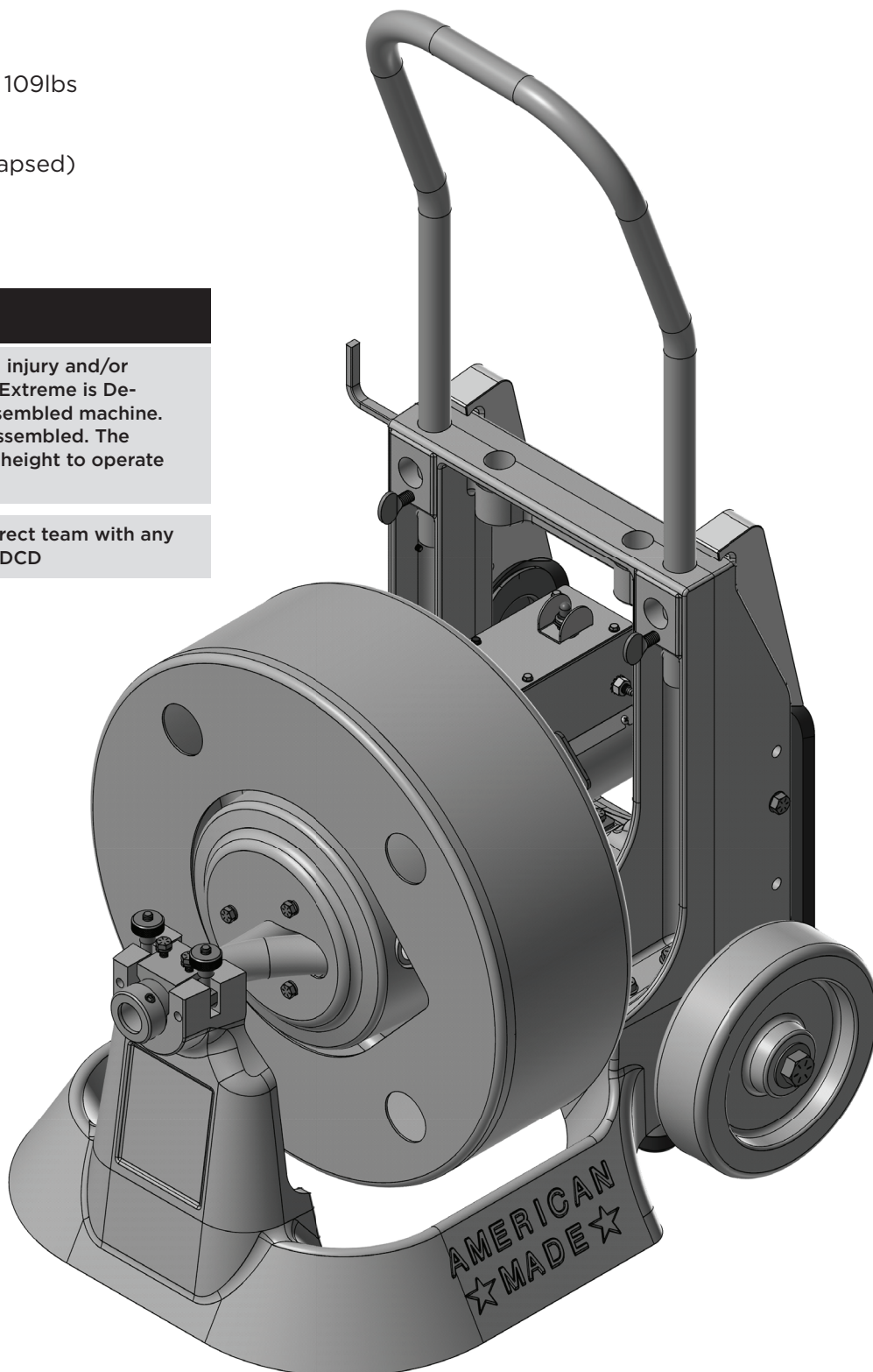

MACHINE INSPECTION

WARNING

To prevent serious personal injury and/or death, follow these inspection instructions thoroughly prior to each use of the Drincables Direct Valor Extreme.

1. Ensure that the Drincables Direct Valor Extreme is unplugged and the directional switch is set in the **OFF** position.
2. Ensure that the foot switch is present and attached to machine. Do not operate without foot switch.
3. Thoroughly inspect power cord, Ground Fault Circuit Interrupter (GFCI) and plug for any damage. If plug has been modified, is missing the grounding prong or if the cord is damaged, do not use machine until the cord has been replaced.
4. Thoroughly inspect the Drincables Direct Valor Extreme for any broken, misaligned or binding parts, along with any other conditions which may affect the safety of machine. If there are any conditions present whereas the machine cannot be operated safely, do not use machine until the problem has been fully repaired by a qualified technician.
5. Apply proper lubrication to the machine if necessary (see maintenance instructions).
6. Use only tools and accessories that are designed for the Drincables Direct Valor Extreme and meet the needs of application. The use of other tools or accessories made for other equipment is hazardous.
7. Clean any oil, grease or dirt from all equipment handles and controls prior to use. This will reduce the risk of injury from a tool or control slipping from grip of operator.
8. Thoroughly inspect all cutting edges of tools. If needed, sharpen or replace prior to using machine. Dull or damaged cutting tools can lead to cable breakage or binding.
9. Thoroughly inspect cables and couplings for damage and wear prior to use of the Drincables Direct Valor Extreme. Cables should be replaced when they become damaged, kinked, are severely worn or corroded. A worn cable can be identified when the outside coils become flattened.
10. After inserting cable, tighten bolts on the back of the drum to secure cable.

MACHINE SET UP:

WARNING

To prevent serious personal injury and/or death, setting up the Drincables Direct Valor Extreme and work area properly is required.

1. Check Work Area For:
 - Adequate Lighting.
 - Grounded Electrical Outlet.
 - Clear Path to Electrical Outlet (no sources of heat, oil, sharp objects or moving parts) that may cause damage to cord.
 - Dry place for machine and operator. Do not place drain cleaning machine in water.
 - Flammable liquids, fumes or dust that may ignite and cause a fire.
2. Place machine within 2ft of sewer inlet. Greater distances can cause cable twisting or kinking.
3. Place air foot switch pedal in a position allowing to allow easy operator access. The Drincables Direct Valor Extreme is designed for one person only operation. Never engage the air foot switch with any object other than the foot of the operator.
4. Make certain **FOR/OFF/REV** switch is in the **OFF** position.
5. Select and install tools or accessories needed to the end of the cable.
6. Plug the Drincables Direct Valor Extreme into a grounded electrical outlet, positioning cord along a clear path. If the power cord does not reach the plug, use an appropriate extension cord in good condition.

WARNING

To prevent the risk of electrical shock, keep all electrical connections off the ground and dry. Do not touch plug or cords with wet hands. Test the Ground Fault Circuit Interrupter (GFCI) provided with electrical cord to insure correct operation. When the test button is pushed, the indicator light will go off. Reactivate by pushing the reset button in. If indicator light goes on, the machine is ready to use. If the GFCI does not function correctly, do not use the machine.

OPERATING INSTRUCTIONS

Never grasp a rotating cable with a cloth or loose-fitting cloth glove. These items may become wrapped around cable, causing serious personal injury and/or death.

Always wear eye protection when operating the Drincables Direct Valor Extreme. This will prevent dirt, dust and other foreign particles from entering your eyes.

Wear rubber, soled, non-slip shoes to insure stable footing and safety of user.

Be careful when cleaning drains that have been treated with cleaning compounds. Wear gloves at all times when handling cables and avoid direct contact with the skin, eyes and facial areas. Some cleaning compounds can cause serious burns.

WARNING

Always use correct operating posture to maintain proper balance. Posture provides control over machine if an unexpected situation were to arise.

Be sure to quickly remove foot from foot switch.

Keep one hand on cable to control twisting action when it reaches obstruction.

Do not reach into drum unless machine is turned **OFF** and unplugged.

USING MANUAL FEED MACHINES

WARNING

Prior to starting machine, both operator's hands (with gloves on) must be on the cable.

1. Pull cable out of drum to start machine and push cable into sewer inlet as far as it will reach.
2. Move motor switch into the **FOR** (forward) position. Grasp cable with both gloved hands and pull one foot of additional cable out of machine, building a small loop of cable between machine and sewer inlet.
3. Press down on foot switch to start machine. Using both gloved hands, grasp and push cable into sewer inlet. Rotate cable slowly to work it into drain by gently applying downward pressure on cable loop.
4. Continue feeding cable into the line until there is resistance or the obstruction is located. This will be apparent when the motor "lugs" down and/or the cable will twist sideways in hands.
5. If cable loads down into the obstruction, relieve load by pulling back on cable using short, quick jerks to free cutter (drum speed will increase). Advance cable back slowly into the obstruction. Repeat this process as needed until the obstruction is clear. Always make sure the cutter is rotating at all times and never force the cable.

WARNING

Never allow tension to build up in the cable. This will occur if the cutting tool hits a snag and stops turning while motor and drum continue to rotate. Torque builds until the cable twists suddenly and can wrap around operator's hand or arm. This happens quickly and without warning. Proceed slowly and carefully while feeding cable into drain.

6. Once obstruction is cleared, flush debris from line with running water. Repeat step 5 several times if needed for a thorough cleaning job and then work cable through additional blockages as required.

7. To retrieve cable from sewer line, pull 1-2 feet of cable from the sewer, while continuing to run machine in a **FORWARD** rotation. The excess cable should then be pushed manually back into machine. This “push and pull” procedure should be continued until it is apparent that the tool is just inside the sewer inlet.

WARNING

Never retract tool from sewer inlet while cable is rotating. This can cause tool to thrash, causing serious personal injury and/or death.

8. Release foot actuator and allow machine to come to a complete stop.

NOTE: it is recommended that a continuous flush of water be run through the machine to clean cable and tool as they are being retrieved.

9. Turn FOR/OFF/REV switch to the OFF position and remove cord from power source.

10. Pull remainder of cable and tool from sewer and hand feed cable into machine.

NOTE: If cable or tool gets caught in obstruction refer to reverse operating instructions in the special procedures section of this manual.

USING AUTO FEED MACHINES

1. Manually pull sufficient amount of cable out of the drum to begin. Push tool and cable into the sewer inlet. Push cable into inlet as far as it will go.

2. Turn the feed knob down until front bearing makes contact with the cable. Do not over tighten.

3. Move FOR/OFF/REV switch into the FOR (forward) position.

DO NOT STEP ON AIR FOOT SWITCH PEDAL AT THIS TIME.

4. Loosely grasp cable with gloved hand and place right hand on feed lever. The feed lever should be in the neutral position at this time (vertical or “12 o’clock” position). Exert sufficient downward pressure onto cable to

maintain control while depressing foot actuator to start drum rotation. **DO NOT FORCE CABLE.** Allow cable to feed itself into the drain.

5. Move feeder lever in the opposite direction of rotating drum to advance the cable forward. The rate at which the cable is fed – 0-20 feet per minute – into the sewer is controlled by the position of the feed lever away from neutral (vertical) position. The further away from the vertical, the faster the rate of feed.

WARNING

Before starting the Drincables Direct Valor Extreme, operator’s gloved hands must be on cable, and hands should remain on cable at all times in order to feel tension.

6. Continue to feed the cable into the line until resistance or the obstruction is encountered. The condition will become apparent to the operator as the cable will have a tendency to twist sideways in operator’s hands.

7. Operator should respond immediately to this condition by moving feed lever into full reverse (same direction of drum rotation). This will release the twist in cable and reduce the size of cable loop.

8. Once free of obstruction and the load is relieved from cable, slowly and gradually feed cable forward. Using this feed mechanism, the rate of cable advance is controlled by the auto feed handle. Allow cutter to advance slowly and work through obstruction. If loop between machine and drain continues to grow, immediately back cutter from obstruction by reversing feed.

NOTE: at this point, progress depends on the sharpness of the tool and the nature of obstruction. Continued operation may require switching to the manual feed option until the obstruction is cleared.

9. Manually and sharply pull back on the cable to free the cutter and relieve the load on the cable. Slowly advance cable back into the obstruction. Repeat this process until the obstruction has been cleared. Make sure the cutter is rotating at all times and never force the cable. Occasionally, move power feed lever to a neutral position to allow cutter to work through the obstruction.

WARNING

Never let tension build up in the cable. This may happen if the cutting tool hits a snag and stops turning, but the motor and drum continue to rotate. Torque will build until the cable suddenly twists, potentially wrapping around operator's hand or arm. This can happen without warning and rapidly. Proceed with caution, slowly and carefully when feeding cable into drain. If the tool gets hung up in an obstruction, refer to the Reverse Operating Instructions in the Special Procedures section of this manual.

10. It is recommended to make several passes through a blocked drain line. After reestablishing flow, increase cutter size to thoroughly clean line. Flush with a strong flow of water.

11. To retrieve cable from sewer line, move the feed lever in the same direction as the rotation of the drum. The cable should now feed itself back into the machine. The retrieval process is aided by also manually pulling the cable from the drain one foot at a time, at the same time as the auto feed is used.

NOTE: it is recommended that a continuous flush of water be used to clean cable and tool as they are retrieved.

12. When the tool is just inside the sewer inlet, release the air foot switch pedal and allow the machine to come to a complete stop.

WARNING

Never retract tool from sewer inlet while cable is rotating. Tool can thrash, causing serious personal injury and/or death.

13. Turn **FOR/OFF/REV** switch to the **OFF** position.

14. Loosen the feed knob and pull remaining cable and tool from sewer inlet. Manually feed the cable into the machine.

15. Unplug cord from power source with dry hands.

SPECIAL PROCEDURES

REVERSE OPERATION

Running the Drincables Direct Valor Extreme in reverse will cause premature failure of the cable. Only use reverse to free tool if caught in an obstruction. If an obstruction should occur, immediately remove foot from air foot switch pedal and allow machine to come to a complete stop. Place **FOR/OFF/REV** switch to the **REV** (reverse) position.

If machine has an automatic feed, move knob to the neutral position. Grasp cable with a gloved hand and pull while pushing air foot switch pedal. Once tool is dislodged and the drum has stopped rotating, place **FOR/OFF/REV** switch in the **FOR** (forward) position and follow normal operating procedure.

WARNING

Never operate the Drincables Direct Valor Extreme in the **REV** (reverse) position for any other purpose. Operating machine in reverse can damage cable and cause serious personal injury.

REMOVING DRUM

WARNING

FOR/OFF/REV switch must be in the **OFF** position and machine must be unplugged from outlet prior to removing or installing drum.

1. Loosen swing bolts on power feed bracket enough to swing down. Remove power feed from machine.

2. Grasp drum and pull slightly forward to disengage drive from motor then lift free of the machine.

INSTALLING CABLE

WARNING

FOR/OFF/REV switch must be in the OFF position and machine must be unplugged from outlet prior to removing or installing cable.

REMOVE DAMAGED OR WORN CABLE

1. Remove drum from machine as described previously.
2. Pull loose cable from drum. The end of cable is fastened to the back wall of the drum.
3. To free the end of the cable, loosen two bolts on back of drum that clamp at the cable's end against the back wall of the drum.
4. Grasp the neck of the inner-drum and rotate it counter-clockwise to pull cable end from under the bracket.
5. Pull remaining length of cable from drum and discard.

INSTALLING REPLACEMENT CABLE

1. Remove the two retaining rings and clutch assembly from the rear of the drum. Remove inner drum from the outer drum.
2. Insert approximately two feet of cable through the inner drum guide tube into outer drum. Let the cable follow the natural flow of the guide tube.
3. Carefully reach inside the drum and grasp cable near the end. Position cable end under the cable bracket. 2" of cable should protrude past clamp bracket. Cable should be installed in a clockwise rotation.

NOTE: if the cable will not fit under the bracket, loosen the two bolts at the back of drum.

4. With the cable end under the bracket, re-tighten bolts to clamp cable firmly against the back wall of drum.
5. Reassemble inner drum, retaining rings and clutch. Note: retaining rings should not be reused.

6. Lay drum on its back and push cable into drum. Guide tube will evenly distribute the cable around the drum.

7. Mount the drum on machine as described previously in machine assembly instructions.

MAINTENANCE INSTRUCTIONS

WARNING

Ensure that the Drincables Direct Valor Extreme is unplugged completely from electrical system.

CARING FOR CABLES

Drincables Direct Cables are designed so that no specialty care is required. At the end of each day's use, cables and the inside drum should be rinsed thoroughly with water to prevent damage caused by drain cleaning compounds, acids and other compounds that may cause damage to the cables strength.

Cables should be replaced when they become severely worn and/or corroded. A worn cable can be identified when the outside coils become flattened or the cable becomes flexible. It is recommended to use a light weight rust inhibiting oil when cables are not in use. If cables are exposed to acid, this will severely limit the life of the cable.

NOTE: corroded and/or worn cables reduce the efficiency of machine to remove obstructions. New cables reduce the chance of downtime and the time it takes to finish clearing obstructions.

MACHINE STORAGE:

Electric and motor driven machinery must be kept indoors or well covered in rainy weather conditions.

NOTE: Drain any excess water out of drum prior to storing.

CLEANING AND LUBRICATING

WARNING

This cleaning of parts instruction recommends the use of kerosene for cleaning parts. Kerosene is a combustible product and care should be used when handling.

Always work in a well-ventilated area that is away from fire, open flame, or other easily flammable materials. When cleaning parts, always wear proper eye protection, rubber gloves and a plastic or rubber apron. After cleaning is complete, dispose of all cleaning rags and waste cleaner in the proper waste receptacle.

NEVER USE GASOLINE OR ANY OTHER HIGHLY FLAMMABLE SUBSTANCE FOR CLEANING PARTS.

Disassemble unit. All parts with the exception of the drive rollers and “O” rings, should be soaked and cleaned in kerosene. This will remove all grease and grime from parts. After soaking, wipe parts and allow to dry completely prior to lubricating in assembly. Drive rollers and “O” rings should be wiped clean only (do not place in cleaner).

Rollers are per-lubricated and sealed. If drive bearings are hard to turn or frozen, refrain from turning and replace with new parts. We recommend the purchase of additional drive bearings and “O” rings for replacement when necessary.

Lubrication of drive parts should be done while reassembling parts. We recommend using a multipurpose lithium grease that is water resistant.



ONE YEAR WARRANTY

Draincables Direct warrants its equipment to be free from defects in material and construction for one year from the date of purchase.

To obtain warranty service, purchaser must notify Draincables Direct in writing, at the provided address, within the one year warranty period. Draincables Direct will then advise on where to take or send equipment for servicing.

If the defect is covered by warranty and is within warranty period, Draincables Direct will repair or replace, at its option, the defective equipment, at no charge for labor or materials.

Freight and Insurance are at the responsibility of the purchaser.

The warranty is limited to the original purchaser and is non-transferable. Draincables Direct assumes no responsibility for damage occurring from accident, neglect, abuse, tampering or misuse of the product. Draincables Direct also assumes no responsibility if product is damaged during repairs or alterations made by others. This warranty does not cover damage to equipment as the result of using replacement parts other than those from Draincables Direct.

Draincables Direct's sole obligation is to the original purchaser for repairs or replacements described above while product is under warranty. All other warranties, expressed or implied, including but not limited to implied warranties of merchantability and fitness for a particular purpose are disclaimed. In no event shall Draincables Direct be liable for any incidental or consequential damages.

Draincables Direct
Millbury, OH 43447

*Draincables Direct reserves the right to make changes at any time, without notice, to the specifications, models, as well as discontinue models. The right is also reserved to change specifications of parts at any time without incurring any obligation to equip same on models manufactured prior to the date of change.

Draincables Direct
4370 Moline Martin Rd
Millbury, OH 43447
855.746.7323

VALOR EXTREME FULL ASSEMBLY

DCD01900

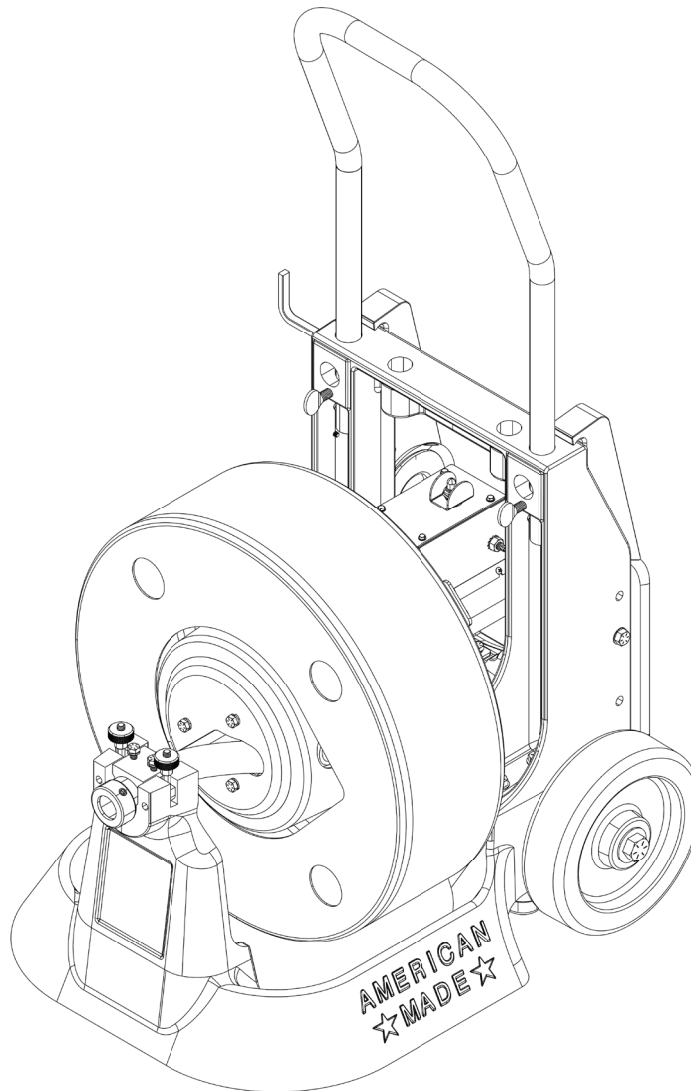
**Reference #:****Description**

Full Assembly
Drum Assembly
Motor Assembly
Clutch Assembly

Part #:

DCD01900
DCD19056
DCD19140
DCD01052

CLUTCH ASSEMBLY

DCD01952

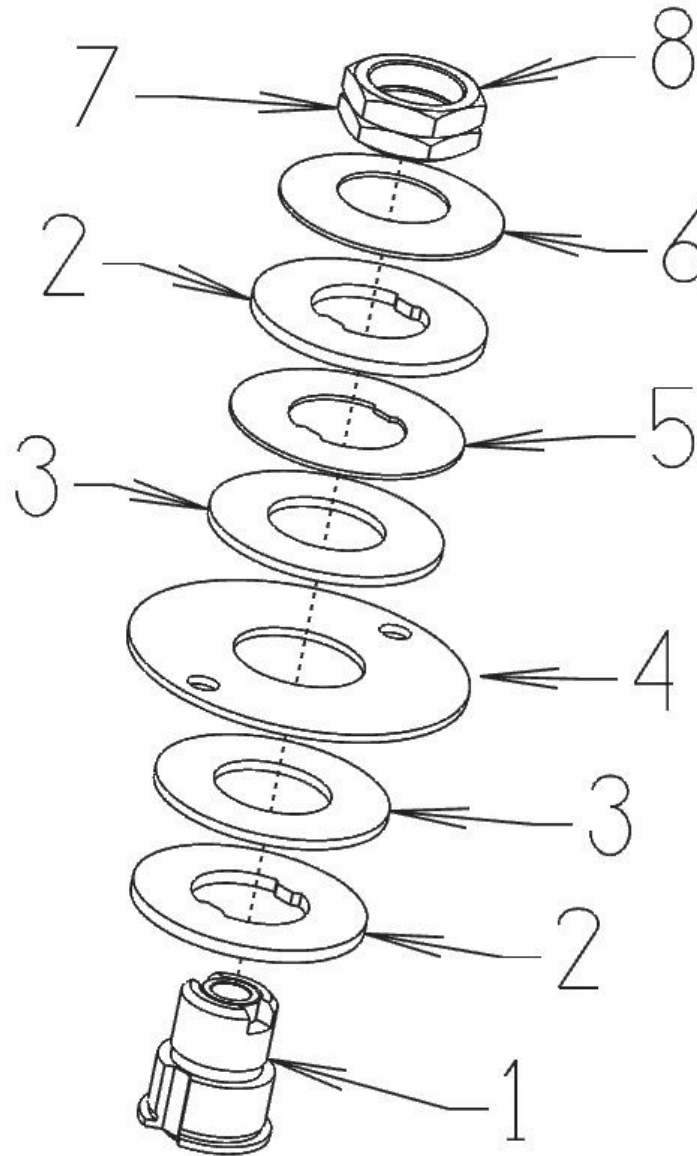

Reference #:	Description	Part #:
1	Drive Coupler	DCD01085
2	Drive Plate	DCD01109
3	Friction Disk	DCD01120
4	Drive Disk	DCD01103
5	Spacer Plate	DCD01113
6	Disk Spring	MG2750-087
7	Location Nut	DCD01110
8	Jam Nut	DCD01220

DRUM ASSEMBLY

DCD19056

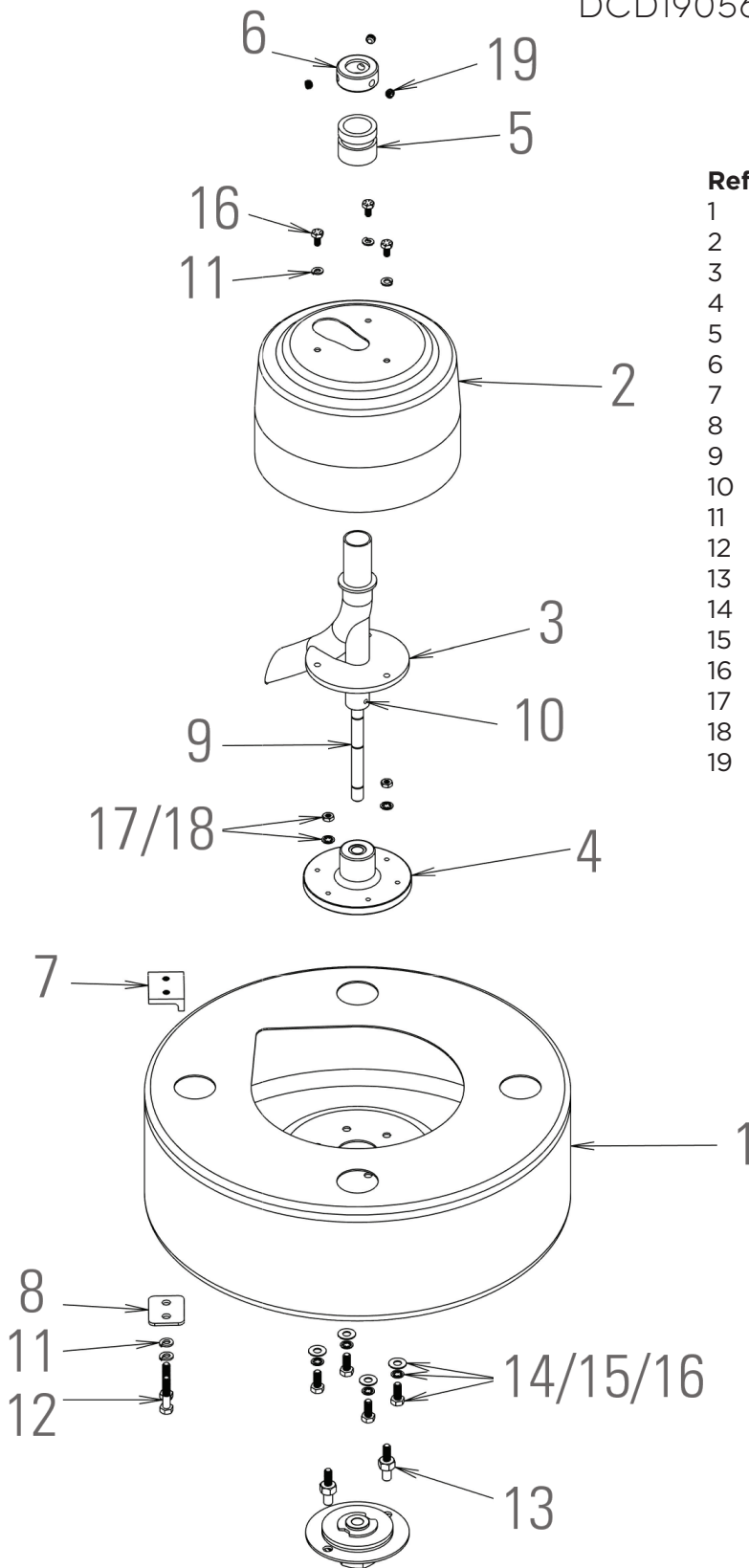

Ref #:	Description	Part #:
1	Outer Drum	DCD19087
2	Inner Drum	DCD19101
3	Feed Tube Mount	DCD19128
4	Drive Mount	DCD01088
5	Bronze Bearing	DCD19103
6	Feed Tube Collar	DCD19130
7	Cable Clamp	DCD19131
8	Clamp Back Plate	DCD01124
9	Main Shaft	DCD01111
10	1/4-20 x 3/8" Set Screw	25C37KKC
11	5/16" Split Washer	31NLOC8Y
12	5/16-18 x 1-1/2" Hex Bolt	31C150HCS8Y
13	Drive Pin	DCD01104
14	5/16" Flat Washer	31NWSA8Y
15	5/16 Int. Tooth Washer	31NLITS
16	5/16-18 x 3/4" Hex Bolt	31C75HCS8Y
17	5/16 Int. Tooth Washer	31NLITS
18	5/16-18 Jam Nut	31CHJOP
19	3/8-16 x 1/4 Set Screw	37C25KKC

MOTOR ASSEMBLY

DCD19140

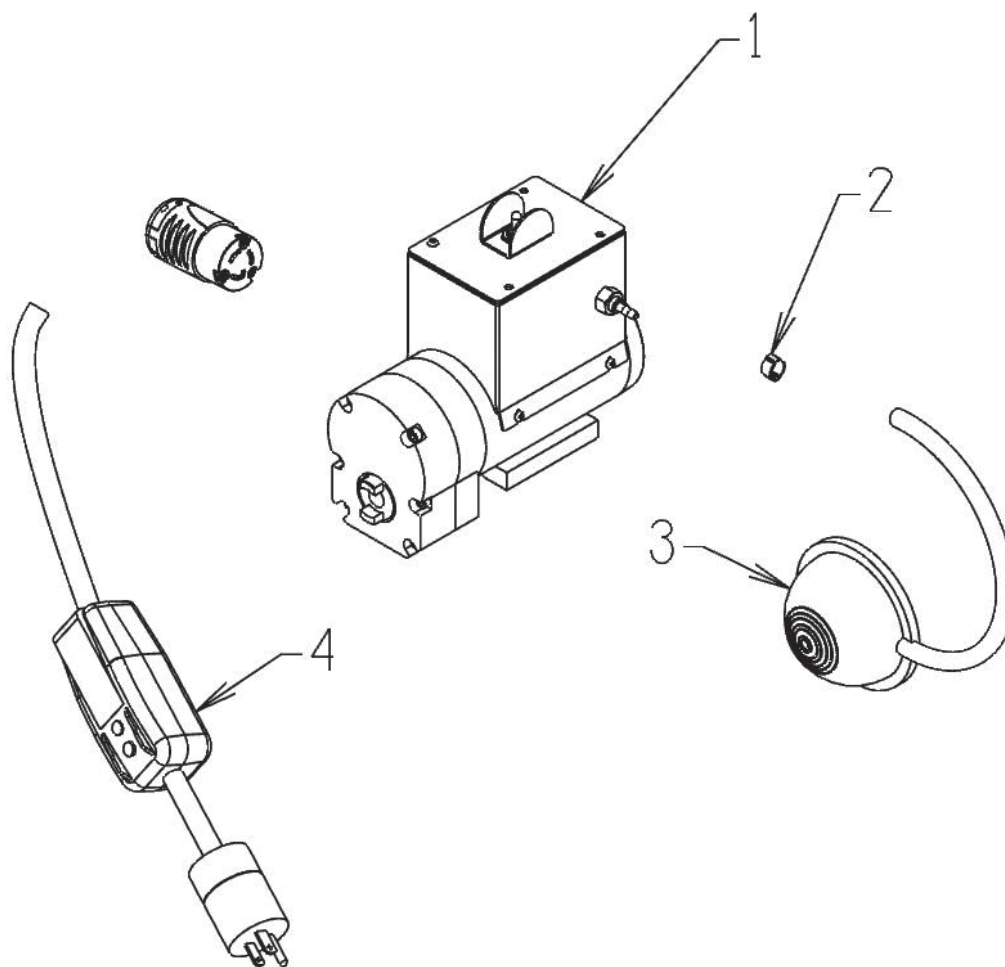

Reference #:

- 1
- 2
- 3
- 4

Description

- Motor & Circuit Box
- Hose Clamp
- Foot Switch
- GFI Cord

Part #:

- PR18018
- OE10100016
- FS100
- GFI0251



855.SHOP.DCD | dcddrain.com