



WHR MAGNUM SERIES CONTROLLED ROTATION SEWER NOZZLE AND SWITCHER HEAD USER MANUAL



TABLE OF CONTENTS

MANUFACTURER'S INFORMATION	3
SPECIFICATIONS.....	3
DESCRIPTION AND INTENDED USE.....	3
KEY FEATURES	3
TOOL OVERVIEW	4
WHR MODELS AND HEAD SPECIFICATION INFORMATION.....	4
TOOL WEIGHTS AND DIMENSIONS	5
WARNING AND SAFETY INSTRUCTIONS	6
OPERATION	8
TROUBLESHOOTING	9
FLUID REPLACEMENT	10
WHR MAGNUM MAINTENANCE TOOLS AND MATERIALS	11
DISASSEMBLY	12
ASSEMBLY	16
WHR SWITCHER 1/2 AND 3/4	21
OVERVIEW	21
WHR SWITCHER MAINTENANCE TOOLS AND MATERIALS.....	21
OPERATION AND TROUBLESHOOTING	22
WHR SWITCHER DISASSEMBLY	23
WHR SWITCHER ASSEMBLY.....	24
WHR AND SWITCHER MAINTENANCE SCHEDULE	25
PART NAMES/NUMBERS AND SERVICE KITS	26
TERMS AND CONDITIONS AND WARRANTY	28

StoneAge Inc.
466 S. Skylane Drive
Durango, CO 81303, USA
Phone: 970-259-2869
Toll Free: 866-795-1586
www.stoneagetools.com

StoneAge NL
Reedijk 7Q
3274 KE Heinenoord
Netherlands
(+31) (0) 85 902 73 70
sales-NL@stoneagetools.com

StoneAge UK
Unit 3
Crucible Business Park
Woodbury Lane
Norton
Worcester
Worcestershire, WR5 2DQ
United Kingdom
+44 (0) 1684 892065
sales-eu@stoneagetools.com

This manual must be used in accordance with all applicable national laws. The manual shall be regarded as a part of the machine and shall be kept for reference until the final dismantling of the machine, as defined by applicable national law(s). Updated manuals can be downloaded at:

<https://www.stoneagetools.com/manuals>

SPECIFICATIONS				
Tool Family:	Warthog Magnum			
Tool Model:	WHR-1/2		WHR-3/4	
Units:	Imperial	Metric	Imperial	Metric
Pipe Size:	6-18 in.	152-457 mm	6-18 in.	152-457 mm
Pressure Range:	1500-8000 psi	100-550 bar	1500-8000 psi	100-550 bar
Flow Range:	14-50 gpm	60-190 lpm	14-50 gpm	60-190 lpm
Outside Diameter:	3.625 in.	92 mm	3.625 in.	92 mm
Overall Length:	7.25 in.	184 mm	7.25 in.	184 mm
Weight:	6.75 lbs	3 kg	6.75 lbs	3 kg
Inlet Connection:	1/2" NPT or BSPP		3/4" NPT or BSPP	
Nozzle Ports:	5 x 1/8" NPT		5 x 1/8" NPT	
Rotation Speed:	150-400rpm			
Flow Rating:	2.6 Cv			
Pulling Force:	Reference http://jetting.stoneagetools.com/#/t/sw for values			

DESCRIPTION OF EQUIPMENT AND INTENDED USE

The Warthog WHR Magnum is designed for mid-size pipes and lines, with the proven power and durability of the Magnum line of sewer tools.

KEY FEATURES:

- Optimized speed control extends maintenance intervals
- Streamlined design prevents tool from catching inside of piped.
- Replaceable fins made of hardened steel for longer life available in different sizes.
- Flush style head protects front shaft seals for extended fluid life.
- Easily convertible from pulling to rescaling
- Descaling ports now come standard.
- Latest seal technology effectively handles dirty or recycled water for improved performance
- Choose your rotation speed with 3 viscous fluid options.

WHR MODELS AND HEAD SPECIFICATION INFORMATION

TOOL CONFIGURATION

Warthog sewer nozzles come in standard, descaling, and pulling configurations.

Standard nozzles utilize controlled rotation technology and a balanced jetting configuration to deliver superior results in nearly all applications. We also offer nozzles that tune descaling or pulling performance for a variety of special conditions.

See the illustration below for the relationship between jet angle and performance characteristics.

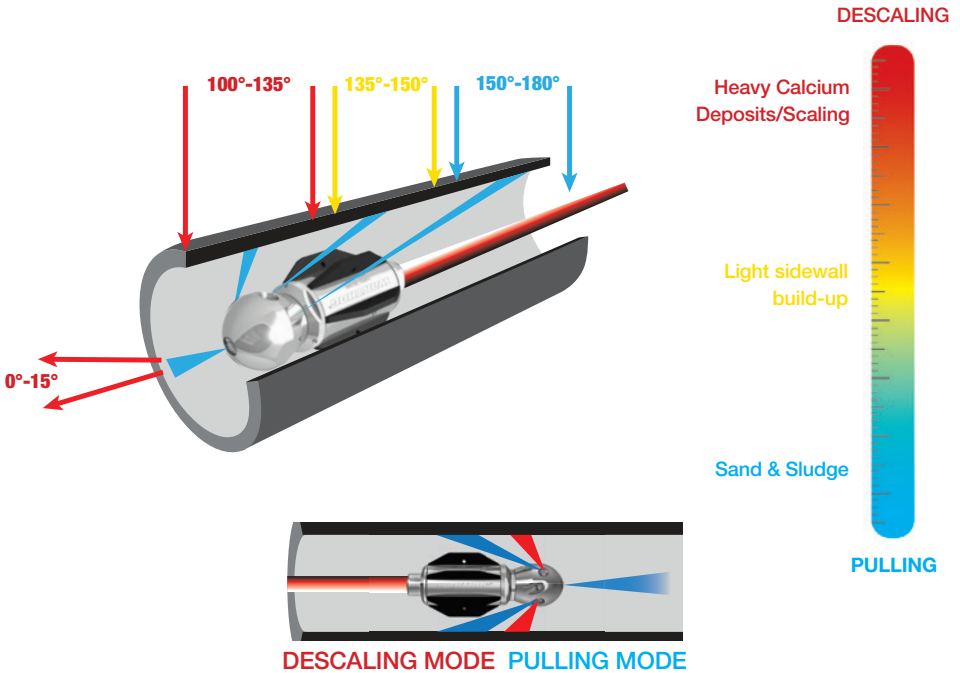

Choose the WHR configuration below that meets the needs of your job, based on **descaling** power, more **pulling** power

WHR TOOL LINE

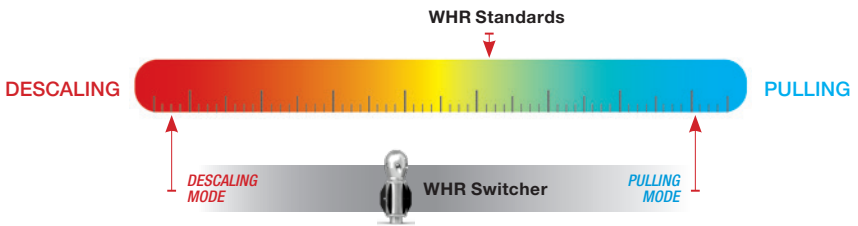

WHR MODELS AND HEAD SPECIFICATION INFORMATION

DESCRIPTION

The Magnum Series Warthog WHR (hereafter WHR) Controlled Rotation Sewer Nozzle is designed for waterjet cleaning of pipes and sewer lines.

- Jet thrust from the water powers the rotation of the head and pulls the tool through the line.
- The WHR is available with one of four female threaded inlet nuts; 1/2" NPT, 3/4" NPT, 1/2" BSPP, or, 3/4" BSPP
- The WHR is capable of working pressures up to 8000 psi and flow rates of 14 to 50 gpm.
- The carbide face seals allow the use of recycled water or fresh water for jetting.
- The nozzle utilizes a rotor and viscous fluid speed control mechanism to provide consistent rotation speed.
- As with all Warthog nozzles, the orifice sizes are selected to best match the desired operating conditions of pressure and flow.
- Hose length and size must be known to correctly determine the proper orifice sizes.
- Contact your distributor or reference <https://www.warthog-nozzles.com/> to help in nozzle selection.

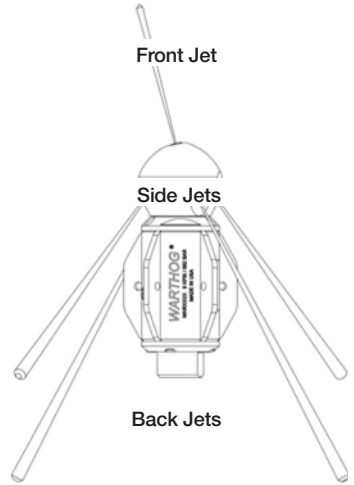

STANDARD HEAD OPTIONS									
MODEL/ INLET CONNECTION	PRESSURE		FLOW		HEAD TYPE	1/8" NPT NOZZLE PORTS			JET TYPE/ PORT PLUG
	psi	bar	gpm	lpm		FRONT JET Δ	SIDE JET Δ	BACK JET Δ	
WHR-1/2	1200- 8000	83- 552	14-20	53-76	WHR 040-R38	1 @ 15°	2 @ 125°	2 @ 152°	CNP2/ GP 025- P2SS
WHR-3/4			30-50	114-189	WHR 040-R18				
			20-40	76-151	WHR 040-R28				
			14-20	53-76	WHR 040-R38				
SWITCHER HEAD OPTIONS									
MODEL/ INLET CONNECTION	PRESSURE		FLOW		HEAD TYPE	1/8" NPT NOZZLE PORTS			JET TYPE/ PORT PLUG
	psi	bar	gpm	lpm		FRONT JET Δ	SIDE JET Δ	BACK JET Δ	
WHR-1/2-SWT	1200- 8000	83- 552	14-45	53-170	WHR 040-R38-SWT	1 @ 15°	2 @ 115°	2 @ 155°	CNP2/ GP 025- P2SS
WHR-3/4-SWT			30-45	114-170	WHR 040-R18-SWT		3 @ 115°	3 @ 155°	
			20-40	76-151	WHR 040-R28-SWT		2 @ 100° 2 @ 125°	4 @ 155°	
WHR-3/4- SWT-HYBRID			1200- 5000	83- 345	30-50		114-189	WHR 040-R20-SWT	

WARNING AND SAFETY INSTRUCTIONS

OPERATOR TRAINING

Managers, Supervisors, and Operators **MUST** be trained in Health and Safety Awareness of High-pressure Water Jetting and hold a copy the Water Jetting Association (WJA) Code of Practice, or equivalent (see www.waterjetting.org.uk).

Operators **MUST** be trained to identify and understand all applicable standards for the equipment supplied. Operators should be trained in manual handling techniques to prevent bodily injury.

StoneAge has designed and manufactured this equipment considering all hazards associated with its operation. StoneAge assessed these risks and incorporated safety features in the design. StoneAge **WILL NOT** accept responsibility for the results of misuse.

IT IS THE RESPONSIBILITY OF THE INSTALLER/ OPERATOR to conduct a job specific risk assessment prior to use. Job specific risk assessment **MUST** be repeated for each different set up, material, and location.

The risk assessment **MUST** conform to the Health and Safety at Work Act 1974 and other relevant Health and Safety legislation.

PERSONAL PROTECTIVE EQUIPMENT REQUIREMENTS

Use of Personal Protective Equipment (PPE) is dependent on the working pressure of water and the cleaning application. Managers, Supervisors, and Operators **MUST** carry out a job specific risk assessment to define the exact requirements for PPE. See Protective Equipment for Personnel (Section 6) of WJTA-IMCA's Recommended Practices For The Use Of High-pressure Waterjetting Equipment for additional information.

Hygiene - Operators are advised to wash thoroughly after all waterjetting operations to remove any waterblast residue which may contain traces of harmful substances.

First aid provision - users **MUST** be provided with suitable first aid facilities at the operation site.

Operators **MUST** read, understand, and follow the Operational and Training Requirements (Section 7.0) of WJTA-IMCA's Recommended Practices For The Use Of High-pressure Waterjetting Equipment, or equivalent.

Operators **MUST** read, understand and follow the Warnings, Safety Information, Assembly, Installation, Connection, Operation, Transport, Handling, Storage, and Maintenance Instructions detailed in this manual.

The risk assessment **MUST** consider potential material or substance hazards including:

- Aerosols
- Biological and microbiological (viral or bacterial) agents
- Combustible materials
- Dusts
- Explosion
- Fibers
- Flammable substances
- Fluids
- Fumes
- Gases
- Mists
- Oxidizing Agents

PPE may include:

- **Eye protection:** Full face visor
- **Foot protection:** Kevlar® brand or steel toe capped, waterproof, non-slip safety boots
- **Hand protection:** Waterproof gloves
- **Ear protection:** Ear protection for a minimum of 85 dBA
- **Head protection:** Hard hat that accepts a full face visor and ear protection
- **Body protection:** Multi-layer waterproof clothing approved for waterjetting
- **Hose protection:** Hose shroud
- **Respiratory protection:** May be required; refer to job specific risk assessment

WARNING

Operations with this equipment can be potentially hazardous. Caution **MUST** be exercised prior to and during equipment and water jet tool use. Please read and follow all of these instructions, in addition to the guidelines in the WJTA Recommended Practices handbook, available online at www.wjta.org. Deviating from safety instructions and recommended practices can lead to severe injury and/or death.

- Do not exceed the maximum operating pressure specified for any component in a system.
- The immediate work area **MUST** be marked off to keep out untrained persons.
- Inspect the equipment for visible signs of deterioration, damage, and improper assembly. Do not operate if damaged, until repaired.
- Make sure all threaded connections are tight and free of leaks.
- Users of the Warthog® WHR **MUST** be trained and/or experienced in the use and application of high-pressure technology and cleaning, as well as all associated safety measures, according to the WJTA Recommended Practices for the use of High-pressure Waterjetting Equipment.
- Install mechanical stops, stingers and back out preventers as appropriate when doing any tube, pipe or vessel cleaning.
- Always de-energize the system before servicing or replacing any parts. Failure to do so can result in severe injury and/or death.

PRE-RUN SAFETY CHECK

Refer to WJTA-IMCA's, Recommended Practices For The Use Of High-pressure Waterjetting Equipment and/or The Water Jetting Association's, WJA Code of Practice for additional safety information.

- Complete a job specific risk assessment and act on the resulting actions.
- Adhere to all site specific safety procedures.
- Ensure the waterblasting zone is properly barricaded and that warning signs are posted.
- Ensure the workplace is free of unnecessary objects (e.g. loose parts, hoses, tools).
- Ensure all Operators are using the correct Personal Protective Equipment (PPE).
- Check that the air hoses are properly connected and tight.
- Check all hoses and accessories for damage prior to use. Do not use damaged items. Only high quality hoses intended for waterblast applications should be used as high-pressure hoses.
- Check all high-pressure threaded connections for tightness.
- Operate the high-pressure water at full pressure and use the Pneumatic Foot Pedal Dump Control to verify that the dump valve is working properly.
- Ensure that Operators never connect, disconnect, or tighten hoses, adapters, or accessories with the high-pressure water pump unit running.
- Ensure no personnel are in the hydroblasting zone.

⚠ DANGER

Do not attempt to clean a manhole with the WGR hanging by the hose. The tool can turn around and strike the Operator. Specific accessories are offered and are required to safely clean manholes. Do not allow the tool to enter a manhole or vault while in operation. If the tool is not contained in a pipe it presents a serious hazard and if not avoided could result in death or serious injury.

NOTE: A 15-25 foot long section of leader hose of a different color than the jetter hose is recommended to indicate how close the tool is to exiting the pipe.

- Flush the jetter hose prior to installing the nozzle to remove debris. Install the hose guard or Tiger Tail. If the WHR is being used in pipe diameters less than 10 inches it can be attached directly to the hose end. If being used in larger pipes a straight rigid pipe or centralizer must be placed behind the tool such that the rigid length is greater than the pipe diameter to ensure the tool cannot turn around in the pipe.
- To clean lines, position the WHR and Tiger Tail so it can enter the pipe to be cleaned. The recommended cleaning direction is upstream from the manhole.
- Slowly bring the pump up to pressure, making certain that the WHR begins to pull its way into the pipe in the proper direction; allow it to advance a few feet and note the location of the leader hose or other hose marker being used. Once the pump is up to operating pressure, feed out the reel at a reasonable rate to allow the jets time to clean the pipe.
- If roots are present, feeding at a slower rate will improve the cleaning results. Depending on the amount of debris in the pipe, it may be necessary to occasionally pull the WHR back toward the manhole to prevent buildup of debris behind the tool.
- When finished cleaning, withdraw the tool back to its initial starting point noted by the location of the leader or hose marker.
- Shut down and secure the pump before removing the WHR from the line.
- After the job has been completed, remove the WHR from the hose and blow out the water with compressed air to prolong the life of the internal components.

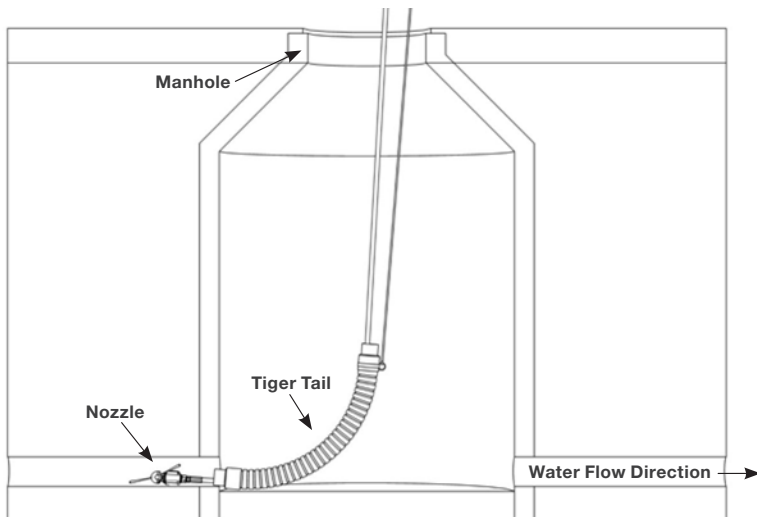

Figure 1. Proper Nozzle Setup

HEAD WILL NOT ROTATE:

- Check to see if any jets, or inserts, are plugged. Even if a jet is only partially blocked it can keep the head from rotating. Jets must be removed from the head to be properly cleaned. Poking the material plugging the jet back into the head will not fix the problem because it will re-plug the jet once water starts flowing. If the jets are all clear, wash the nozzle off with water to remove any debris or grit between the head, body and shaft. Then try rotating head by hand. It should feel free with a slight amount of smooth resistance. If it feels rough, gritty, or hard to turn, the tool needs to be repaired. It may need new bearings and shaft seals or high pressure seals. It is possible the tool needs viscous fluid added or changed, but if viscous fluid is confirmed to be present, a rebuild should be considered.

HEAD SPINS TOO FAST:

- If the nozzle is spinning significantly faster than normal, or if the nozzle starts to sound different (like a jet engine or a turbo charger) the nozzle may be low on viscous fluid, or the viscous fluid may be contaminated. In this case, add or change the fluid as appropriate. Continued operation in this state can mechanically damage the tool and a rebuild may be required to replace the faulty shaft seals.

HIGH-PRESSURE WATER SEALS LEAK:

- The WHR's seal design uses a slight amount of water for lubrication. At full pressure it should not leak more than a few drops with a new set of seals. The high pressure seals may need to be replaced if you are not able to get to full pressure or when a continuous spray comes from under the WHR 020 Back Plate.

LOCK-UP TROUBLESHOOTING TIP:

- Rotate in reverse 1 1/4 to 1 1/2 turns to unlock braking mechanism. If tool rotates smoothly then redress may not be required.
- If the head rotates freely by hand, check the jet sizes and calculate pressure loss through the coil tubing and check with your distributor or StoneAge® to make certain there is enough jet torque to provide rotation.
- Verify jetting at <http://jetting.stoneagetools.com/#/t/sw> contact your factory authorized Warthog® dealer or contact StoneAge®, Inc.

TO KEEP THE TOOL RUNNING AT ITS BEST, PLEASE FOLLOW THE MAINTENANCE SCHEDULE IN THIS MANUAL

FLUID REPLACEMENT

SPEED CONTROL FLUID CHANGE

Fluid replacement is made easy with the WHR. Disassembly of the tool is not required, which means there is less chance for contamination and longer overall tool life. Fluid changes should be performed by qualified persons.

This procedure is recommended for replacing the fluid with the same viscosity.

Not all of the fluid will be replaced using this procedure. Full disassembly and cleaning is recommended when changing speed, or viscosity of fluid. The WHR is designed for maximum fluid life and frequent fluid changes should not be required. A complete fluid change is necessary when replacing bearings and shaft seals.

NOTICE

Improper fluid change maintenance can result in reduced bearing or shaft seal life. Use extreme care when performing this procedure. The fluid is thick and only very light pressure should be applied to the syringe. Excess pressure will force fluid past the inner shaft seals and into the bearings.

VISCOUS FLUID REPLACEMENT INSTRUCTIONS

1. Position the tool (preferably mounted in a vise) at an angle with one Port Plug (BJ 026) at the highest point and the other Port Plug at the lowest point. Clean around, then remove the upper Port Plug from the body.
2. Fill the Syringe (BC 410) with viscous fluid by removing the end near the handle, pulling out the plunger, and pouring the Viscous Fluid (BJ 048-x) in to fill the Syringe Body. With plunger re-installed, purge air out of Syringe hose.
3. Screw the syringe into the upper port, then remove the lower Port Plug. Using the assistance of gravity, gently ease the new fluid into the WHR Body while letting the old fluid flow out the opposite hole.
4. Rotate the Head while flushing.
DO NOT PRESSURIZE THE CHAMBER by aggressively forcing in fluid. The fluid is thick and some time is required to complete the flush.
5. Reinstall the exit Port Plug, then remove the Syringe and install the inlet Port Plug.

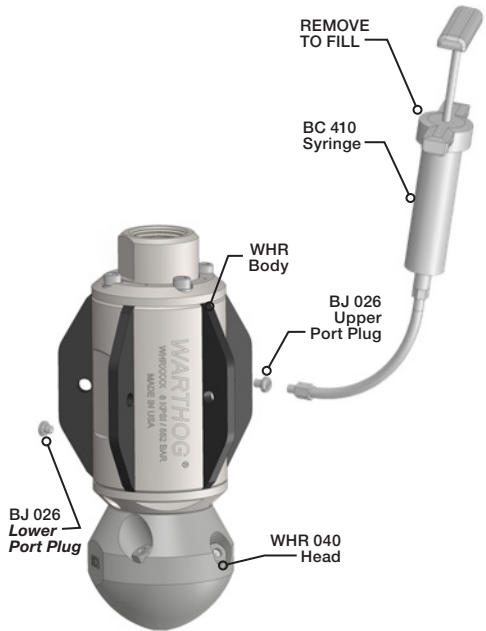

TECH TIP:

The rotation speed of the head can be fine tuned with three different viscous fluid choices to optimize performance for specific applications;

Slow Fluid: BJ 048-S, Medium Fluid: BJ 048-M, Fast Fluid: BJ 048-F

The medium viscosity fluid is recommended by StoneAge for maximized performance and minimized maintenance. Please contact your Dealer or StoneAge Customer Service to select the right fluid for your application.

Product training and proper tools are required to service this nozzle. If you are uncomfortable performing the service, bring the nozzle to your authorized dealer.

The use of a bench vise and an arbor press is recommended. Take care throughout the entire procedure to keep the internals clean and free from grit, lint, and contamination. Failure to do so could result in premature failure after service. See complete Disassembly and Assembly instructions in this manual.

For maintenance videos and more:

<https://www.youtube.com/playlist?list=PL-XpY7HhmpxVkcuc1zG45Wh5w0Vy3MwZ0>

NECESSARY TOOLS:

- 3/8" Drive Ratchet with 3" Extension
- Arbor Press (recommended)
- Bearing Splitter
- Bench vise (recommended)
- Cotton swab
- Large Adjustable Wrench (12" Crescent® Wrench)
- Medium size flat-head screw driver
- Pick
- Rubber Band
- Automotive Sliding Wrench (18" Crescent® C718 Automotive Wrench)
- 5/32" Hex Key

NECESSARY MATERIALS:

- Clean lint free rags or blue shop towels
- Anti-Seize - Swagelok® Blue Goop® StoneAge PN (GP 043)
- Grease - Mobil Mobilux® EP1 StoneAge PN (GP 049)
- Loctite® Blue 242®
- Isopropyl Alcohol
- When installing jets, StoneAge uses Parker® Yellow ThreadMate and Teflon Tape or an equivalent combination on the threads of each jet.

WHR 612 TOOL KIT (INCLUDES)

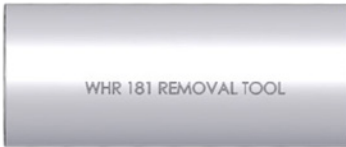

WHR 181
Removal Press Tube



WHR 182
Installation Press



WHR 183
Hex Tool



WHR 187
HP Seal Puller



WHR 184
HP Seal Press



WHR 186
HP Seal Puller



WHR 180
Magnum Shaft Lock Pin

BA 481
Bearing Removal Tool

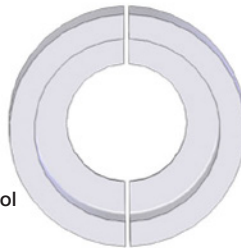

Mobil® and Mobilux® are registered trademarks and/or trademarks of Exxon Mobil®.

Loctite® and Threadlocker Blue 242® are registered trademarks of Henkel AG & Co. KGaA. Blue

Goop® is a registered trademark of Swagelok® Company

DISASSEMBLY

DISASSEMBLY

1. Remove the head by clamping it in a bench vise with the Inlet Nut facing up. Remove the two Brass Set Screws using a 1/8 hex key. Insert the provided Magnum Shaft Lock Pin through the hole in the Front Nut in order to lock the shaft, the Magnum Shaft Lock Pin should stick out the opposite side. Rotating the Body may be required to align the through hole and the shaft. Unscrew the body from the head by hand.

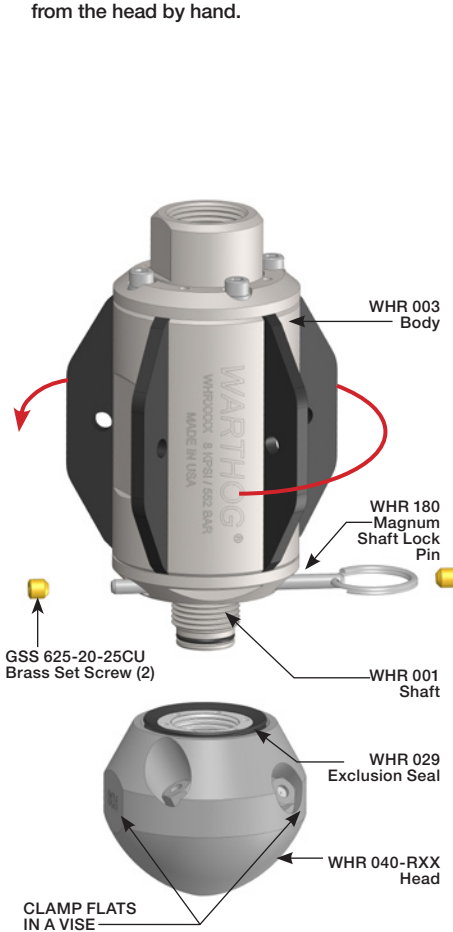

Figure 1: For Step 1

2. Keep the flats of the Front Nut clamped down in a bench vise with the Inlet Nut facing up for the next step.
3. Wrap a rubber band around the fins to keep them from falling out while removing the back plate. Remove the six Torx Screws which attach the Back Plate with a 5/32" Hex Key. Once the Back Plate is off the Fins can then be removed.

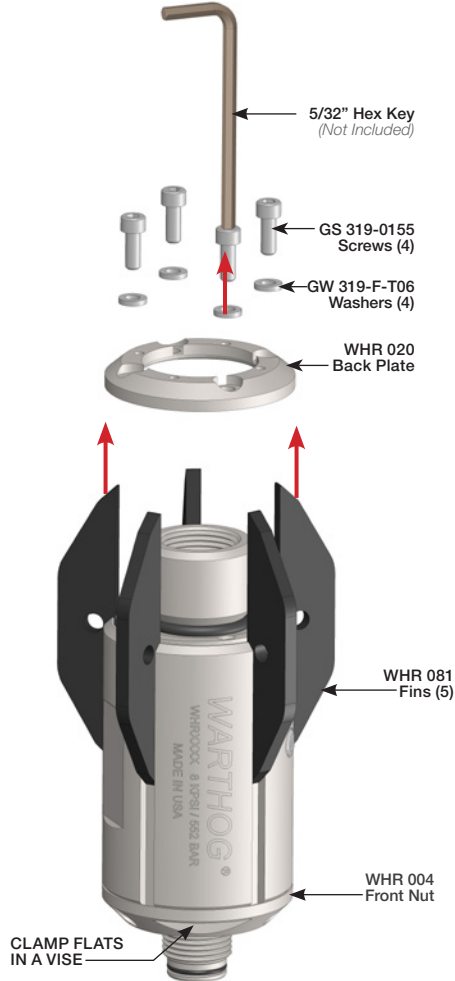

Figure 2: For Steps 2-3

4. With the Body still in the vise, use an Automotive Sliding Wrench on the flats of the Body to carefully hold it in place. Use caution not to deform the Body with too much pressure.
5. Use a Large Adjustable Wrench to remove the Inlet Nut from the Body.

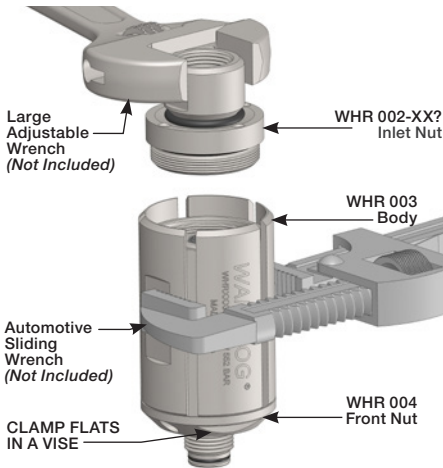

Figure 3: For Steps 4-5

6. Remove the Body from the vise and carefully remove the Wave Spring with a pick.



Figure 4: For Step 6

7. Remove the Port Plug that is closest to the Front Nut with a medium size, flat-head, screw driver.
8. Place the Body flat onto an Arbor Press with the Front Nut facing up. Gently use the press to push down on the top of the Shaft Assembly so that it slips out of the bottom of the Body. Fluid may bleed out of the Port Plug hole during removal. The front Bearing inside the Body should remain in place. The rear Bearing should slide out with the Shaft, along with the Seal Spacer and Shaft Seal when the Shaft is removed.

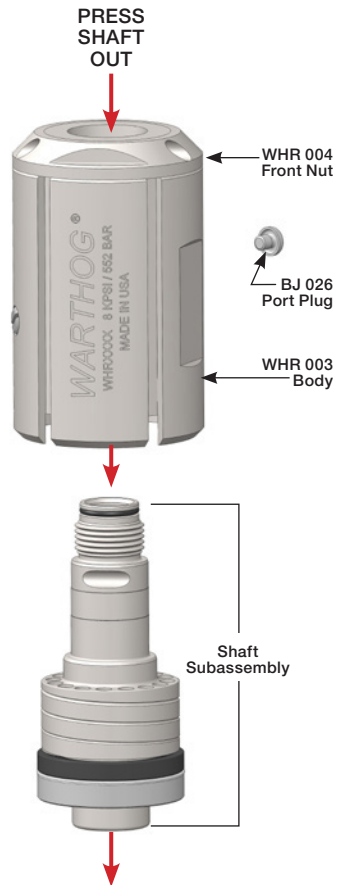

Figure 5: For Steps 7-8

9. Carefully clamp the flats of the Body down in a bench vise. Using a Automotive Sliding Wrench, remove the Front Nut from the Body.

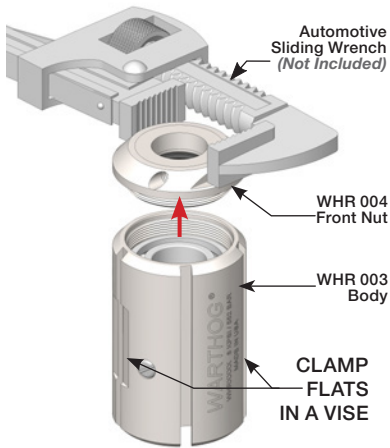

Figure 6: For Step 9

10. Flip the Body over and place onto an Arbor Press. Seat the Removal Tool against the inside of the Shaft Seal to press the Shaft Seal, Seal Spacer, and Bearing out of the Body.

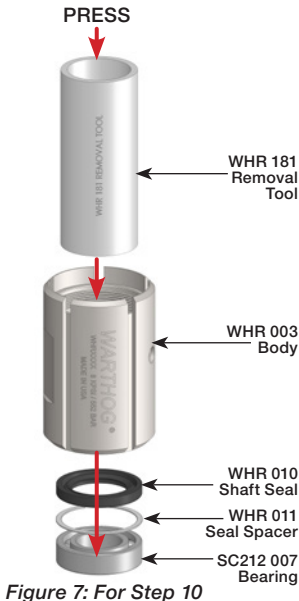

Figure 7: For Step 10

11. Using a pick, remove the Shaft Seal and O-Ring from the Front Nut.

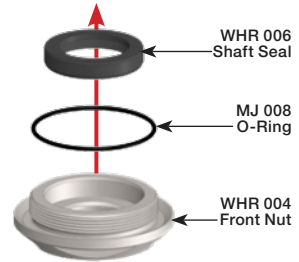

Figure 8: For Step 11

12. Using a pick, remove the Shaft Seal and both O-Rings from the Inlet Nut. Use care to not scratch or damage the seal bore or glands of the Inlet Nut otherwise leakage may occur.

13. Squeeze the HP Seal Puller together and insert it into the bore of the Nut HP Seal, then release. The HP Seal Puller should hook the bottom edge of the Nut HP Seal; pull upward in a circular pattern to work the Nut HP Seal out of the Inlet Nut. Using a pick remove the Wave Spring and O-Ring. Inspect the polished faces, if damaged, replace HP Seal set together.

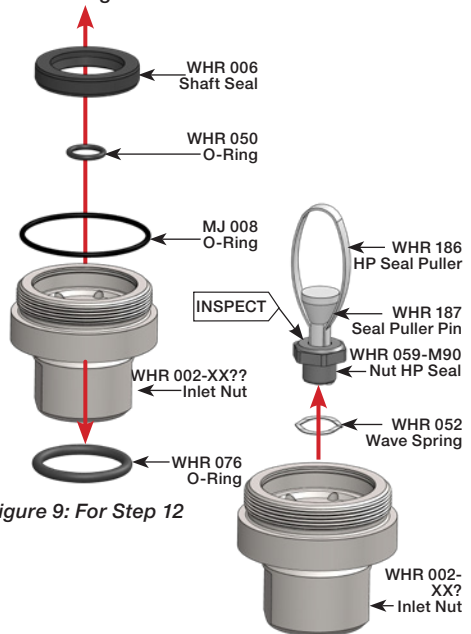

Figure 9: For Step 12

Figure 10: For Step 13

- Squeeze the HP Seal Puller together and insert it into the bore of the Shaft HP Seal, then release. The HP Seal Puller should hook the bottom edge of the Shaft HP Seal; pull upward in a circular pattern to work the Shaft HP Seal out of the Shaft. Remove the Wave Spring. *Removing the Shaft HP Seal is required to prevent it from being damaged while removing the Bearing in the next step.* Inspect the polished faces, if damaged, replace HP Seal set and together.
- Use a pick to remove the O-Rings from the Shaft. Do not scratch the glands in the shaft otherwise leakage may occur.

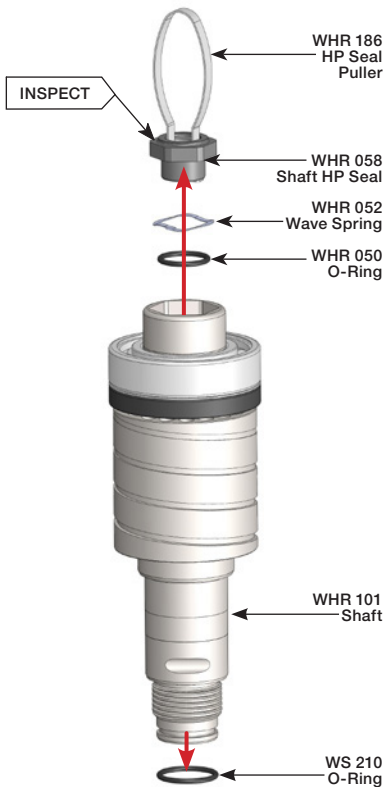
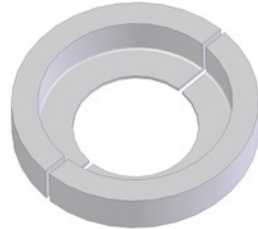

Figure 11: For Steps 14-15

- Evenly seat a Bearing Splitter under the Rear Bearing then press on the end of the Shaft to remove Bearing. Use care to not catch or bend the Seal Spacer. The Seal Spacer and Shaft Seal will then slip off the shaft.



Bearing Splitter BA 481
*Included in WHR 612 Tool Kit

- Inspect the Shaft for grooving where the four shaft seals and bearing ride for signs of the bearings slipping or scratches which extend into the area where the seals operate. Inspect the front shaft lock grooves for interfering deformation. Remove burrs or high spots by gently grinding or filing. If any place is severely damaged or worn, the shaft may need to be replaced.

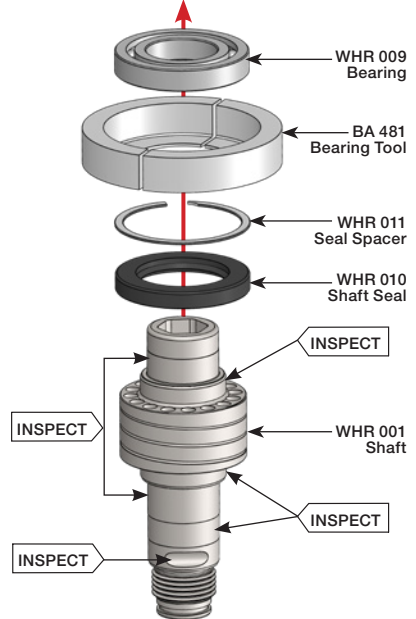

Figure 12: For Steps 16-17

ASSEMBLY

NOTICE

Wash all appropriate parts in solvent and blow dry before assembling. Always use the new replacement parts from our service kits. See the "Service Kit" section of this manual for a list of available replacement parts.

GREASE = Mobil Mobilux® EP1 Tan

ANTI-SEIZE = Swagelok® Blue Goop or Equal

1. Install the O-Ring into the recess inside the bore of the Inlet Nut. Apply grease after it is seated in the recess. Then place the Wave Spring into the Inlet Nut.
2. Apply a light coating of grease to the stem of the Nut HP Seal. Using the HP Seal Press (WHR 184) gently press the Nut HP Seal into the Inlet Nut. Rocking the Nut HP Seal in a small circular pattern while applying light pressure may aid in installation. **Pressing too hard will damage or chip the seal. Always use the Seal Install Tool to avoid damage to the polished face.* The Nut HP Seal should compress freely*

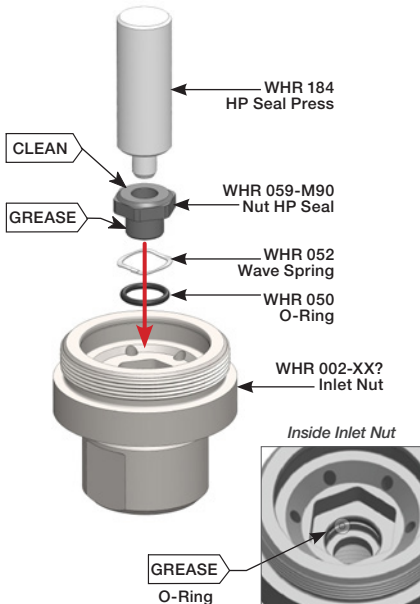

Figure 13: For Steps 1-2

3. Install the Shaft Seal with the lip spring facing down into the Inlet Nut. Generously coat the inside of the Shaft Seal with grease. The O-Ring (MJ 008) seats around the base of the threads. The O-Ring (WHR 076) covers the weep holes.
4. Apply anti-seize to the threads of the Inlet Nut. StoneAge recommends Blue Goop® (GP 043).

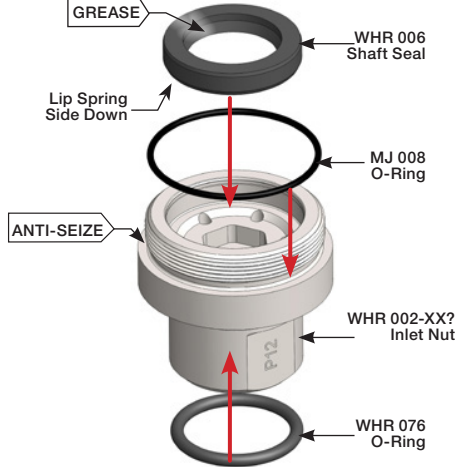

Figure 14: For Steps 3-4

5. Press the Shaft Seal with the lip spring facing down until it is 1/16" below the edge of the Front Nut. Generously coat the inside of the Shaft Seal with grease.
6. Press the O-Ring around and to the base of the threads.
7. Apply anti-seize to the threads of the Front Nut. StoneAge recommends Blue Goop® (GP 043).

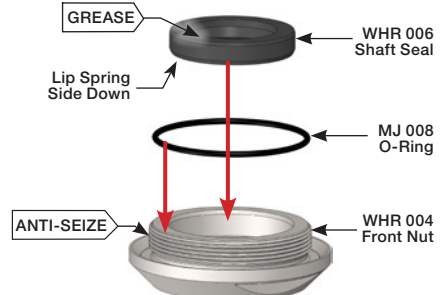

Figure 15: For Steps 5-7



TECH TIP: Before proceeding; The use of an Arbor Press and Install Tube (WHR 182) is recommended for the next three steps.

8. Lightly coat the Shaft Seal with grease. Install with the Shaft Seal with the lip spring facing toward the center of the Body. Install the Seal Spacer on top of the Shaft Seal.
9. Pack and coat every surface of the Front Bearing with grease. Install the Front Bearing and into the Body on top of the Seal Spacer.
10. Install the both Port Plugs (BJ 026). Hand tighten the one closest to the Inlet Nut end.

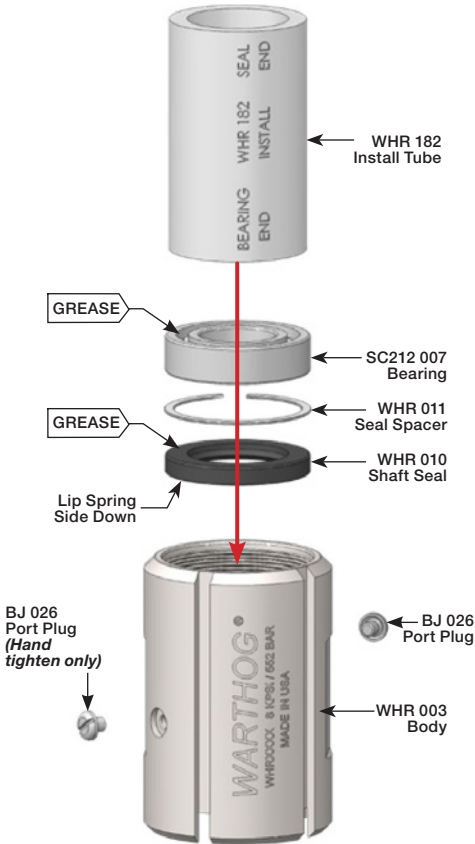

Figure 16: For Steps 8-10

11. Install the assembled Front Nut. Apply anti-seize to the threads of the Body and torque to 115-135 ft-lbs.



Figure 17: For Step 11

12. Flip the Body over so the Front Nut faces down.
13. Lightly coat the Shaft with grease where the Shaft Seals and Bearings ride. Gently insert the Shaft into the Body then push the Shaft into place by hand. The shoulder on the Shaft should stick out slightly from the Front Nut.

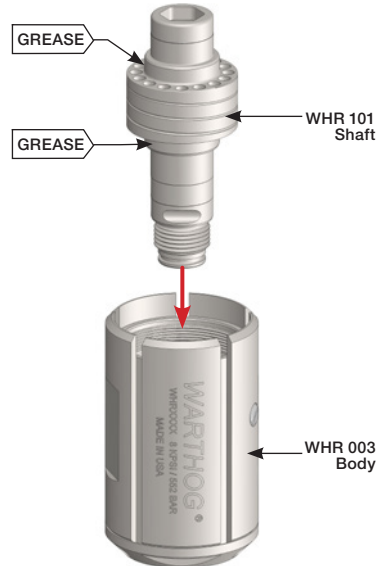

Figure 18: For Steps 12-13

NOTICE

The rotation speed of the head can be fine tuned with three different viscous fluid choices to optimize performance for specific applications;

*Slow: BJ 048-S, Medium: BJ 048-M,
Fast: BJ 048-F*

Medium viscosity fluid is recommended by StoneAge for maximized performance and minimized maintenance. Please contact your Dealer or StoneAge Customer Service to select the right fluid for your application.

- Fill the Body with fluid (BJ 048-M) to the bottom of the chamfer of the shoulder on the Shaft.

⚠ This fluid level height is critical.

- Spin the Shaft to bleed the Fluid. Attach the Hex Tool (WHR 183) to a 3/8" drive ratchet with a 3" extension and insert it into the internal hex in the end of the Shaft. Rotate the Shaft slowly in a Counterclockwise direction to work out all the air bubbles from the system.

💡 TECH TIP:
The viscosity of the fluid is very thick. Be sure to take time to allow all the air bubbles to come out.



Figure 19: For Steps 14-15



TECH TIP:

Before proceeding; The use of an Arbor Press and Install Tube (WGR 182) is recommended for the next three steps.

- Remove the Port Plug furthest from the Front Nut.
- Lightly coat the Shaft Seal with grease. Install the Shaft Seal with the lip spring facing the center of the Body. It is normal for the visc fluid to ooze out of the open port.
- Clean off the excess fluid on the Body and install the Port Plug.
- Install the Seal Spacer on top of the Shaft Seal.
- Pack and coat every surface of the Rear Bearing with grease. Install the Rear Bearing and into the Body on top of the Seal Spacer.

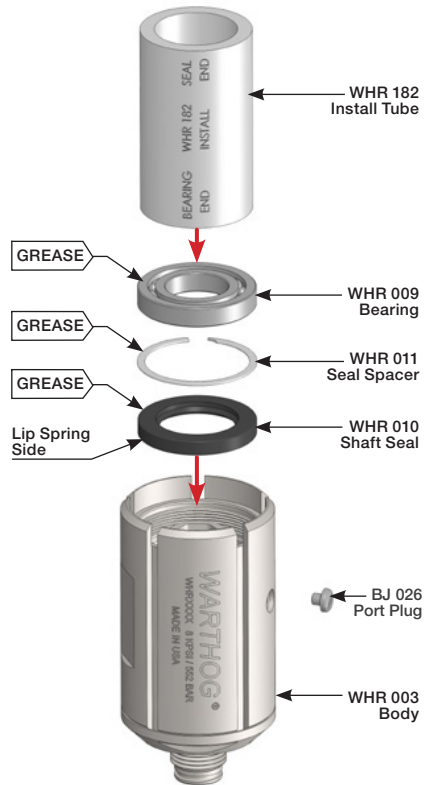

Figure 20: For Steps 16-20

21. Install the O-Ring (WHR 050) into the bore for the Shaft HP Seal. Install the O-Ring (WS 210) into the groove before the start of the Shaft threads. Grease both O-Rings after installation.
22. Place the Wave Spring into the Shaft.
23. Apply a light coating of grease to the stem of the Shaft HP Seal. Using the HP Seal Press (WHR 184) gently press the Shaft HP Seal into the Shaft. Rocking the Shaft HP Seal in a small circular pattern while applying light pressure may aid in installation. Pressing too hard will damage or chip the seal. Always use the Seal Install Tool to avoid damage to the polished face. The Shaft HP Seal should compress freely into the Shaft and spring return.
24. Clean the polished face of the Shaft HP Seal with Isopropyl alcohol. The polished face needs to be clean and free from lint, grease and oils.

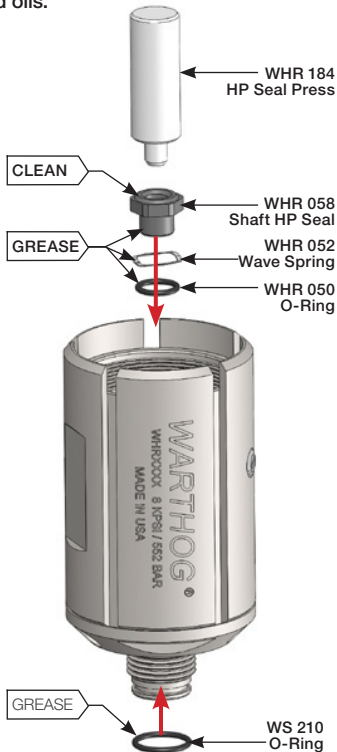

Figure 21: For Steps 21-24

25. Generously coat the Wave Spring with grease. Drop into the Body on top of the Bearing.



Figure 22: For Step 25

26. Apply anti-seize on the threads of the Inlet Nut. Install the Inlet Nut tightly. (A torque of 115-135 ft.-lb. is recommended)
27. Hold the tool at an angle so one of the ports is the highest position, remove the Port Plug to relieve any pressure built up from installing the Inlet Nut then reinstall the Port Plug.

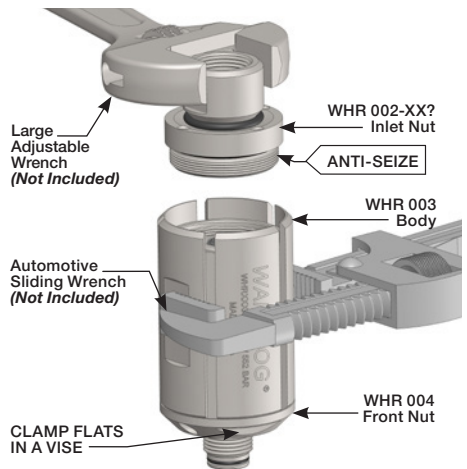

Figure 23: For Steps 26-27



TECH TIP: Keep the flats of the Front Nut clamped down in a bench vise on with the Inlet Nut facing up for the next step.

28. Wrap a rubber band around the Body. Slide each fin in place under the band to keep them from falling out while installing the back plate. Clean the threads of the four GS 319-0155 Screws then apply Blue Loctite® 242 to the threads. Replace the Back Plate and insert the Screws and evenly tighten in a star pattern with a 5/32" Hex Key until they are all tight. (A torque to 70 in-lb. is recommended).

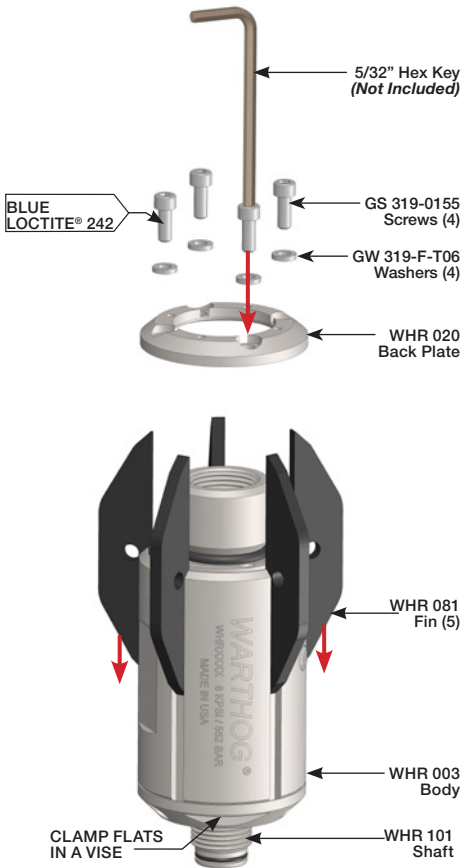

Figure 24: For Step 28

29. Install the Head by clamping the flats in a vise with the threads facing up.
30. Push the provided Magnum Shaft Lock Pin through the first hole in the Front Nut, locking the shaft in place.
31. Make sure the threads on the Shaft and inside the Head are free from grit, debris, and old Loctite®. Make sure the O-Ring on the shaft is clean and in good condition. Apply Blue Loctite® 242 to the Shaft threads and install into the Head tightly. (A torque of 50 ft-lb. is recommended).

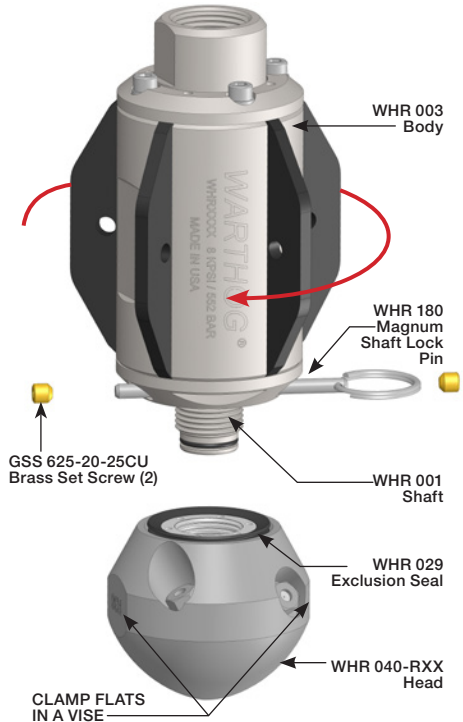

Figure 25: For Steps 29-31



Figure 26: COMPLETE ASSEMBLY

DESCRIPTION AND INTENDED USE:

The Switcher is designed to allow an operator to “switch” between a pulling/flushing mode and a cleaning mode while using the same head. This is made possible by an internal mechanism called a Poppet. When flow is cycled on and off, the Poppet redirects all flow to either the pulling/flushing (back and front) jets or the cleaning (side) jets. One Warthog Switcher Head can perform a cleaning job that would normally require two or more different heads with different jet configurations. Utilizing the Switcher head will increase both time and water consumption savings. The design is more efficient because all of the flow is directed to exactly where it is most useful for either pulling/flushing or cleaning.

WHR SWITCHER PARTS			
MODEL:	1/2"	3/4"	HYBRID
CNP2 XXX Jets	5	7	9
GP 025-SS-P2 Plug	?	?	?
SA 062 O-Ring			4
WGR 060-R20 Switcher Head			1
WGR 062 Cartridge Assembly			1
WGR 064 Poppet			1
WGR 066 Spring			1
WHR 029 Exclusion Seal	1	1	1
WHR 060-RXX Switcher Head	1	1	
WHR 061-.875-1.75 Bushing	1	1	1
WHR 062 Cartridge Assembly	1	1	1
WHR 064 Poppet		1	1
WHR 065 O-Ring	4	4	
WHR 066-001 Spring	1	1	
WHR 067 Poppet	1		

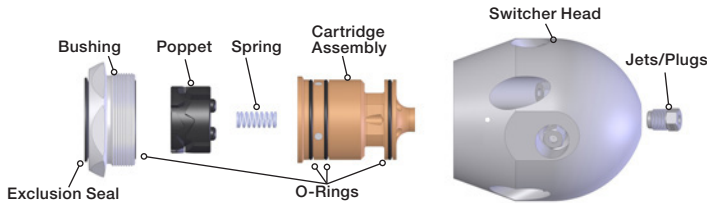

Figure 27: SWITCHER ASSEMBLY

WGR SWITCHER MAINTENANCE TOOLS AND MATERIALS

Product training and proper tools are required to service this nozzle. If you are uncomfortable performing the service, bring the nozzle to your authorized dealer.

Take care throughout the entire procedure to keep the internals clean and free from grit, lint, and contamination. Failure to do so could result in premature failure after service. See complete Disassembly and Assembly instructions in this manual.

For maintenance video:

<https://www.youtube.com/playlist?list=PL-XpY7HhmpxVkcCu1zG45Wh5w0VY3MwZ0>

NECESSARY TOOLS:

- 3/8" Nut Driver
- Arbor Press
- Automotive Sliding Wrench
- (18" Crescent® C718 Automotive Wrench)
- Bench Vise
- Pick
- Pin or needle
- Small Punch

NECESSARY MATERIALS:

- Clean lint free rags or blue shop towels
- Anti-Seize - Swagelok® Blue Goop® StoneAge PN (GP 043)
- Grease - Lithium Complex NLGI 1 StoneAge PN (GP 048)

When installing jets, StoneAge uses Parker® Yellow ThreadMate and Teflon Tape or an equivalent combination on the threads of each jet.

WHR SWITCHER OPERATION AND TROUBLESHOOTING

OPERATION:

Install the WHR Switcher Nozzle onto the hose end. Position hose and nozzle into the pipe to be cleaned. We recommend running the nozzle into the pipe about 3-5 feet. Verify switcher's position of by bringing the nozzle up to operating pressure.

Note:

1. While pressurizing the hose and nozzle expect a pressure jump when the switcher engages, which should be below the operating pressure.
2. In the pulling/flushing mode there will be more tension on the hose versus the cleaning mode. Also listen to the sound and watch the air/water flowing out of the pipe. Faster air/water flowing from the pipe indicates the switcher is in the pulling/flushing mode. Slower air/water flowing from the pipe indicates the switcher is in the cleaning mode.
3. To switch modes, dump pressure from the hose and nozzle until the pressure gauge reads zero. This may take several seconds. Then bring the hose and nozzle back to operating pressure. Repeat these steps to switch between modes as necessary.

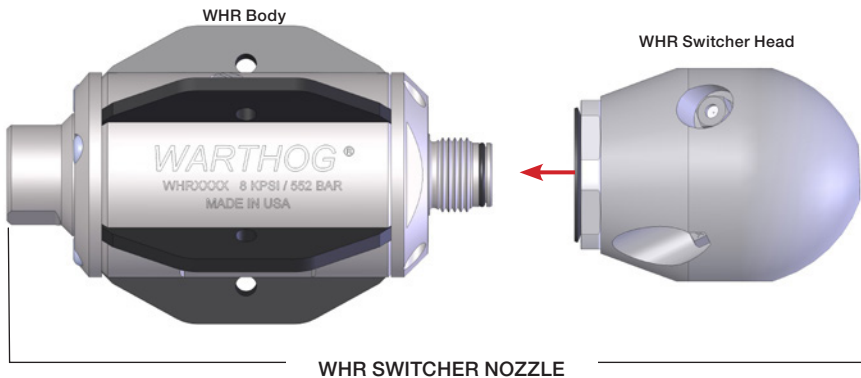

TROUBLE SHOOTING:

Tool Is Not Switching:

- If the Switcher appears to be “stuck” in either the pulling/flushing or cleaning mode, first cycle the pump up and down in pressure several times.
- If cycling the tool doesn't fix the problem, the Switcher Head will need to be removed from the WHR Body and disassembled (refer to the disassembly/assembly page). The Switcher is designed to handle debris up to .030 inches in diameter, but larger particles may lock up the mechanism. Thoroughly clean all the components once disassembled. Examine components for excessive wear or any other visible problems. Once cleaned and examined, the Switcher can be reassembled following the procedure on the second page. If proper switching is not achieved with this procedure, the Switcher will need to be returned to StoneAge for evaluation.

WHR SWITCHER DISASSEMBLY

DISASSEMBLY

1. Secure the wrench flats of the Switcher Head in a vise with the Bushing facing up.
2. Using an Automotive Sliding Wrench, break the Bushing loose from the Head and continue to remove it by hand.

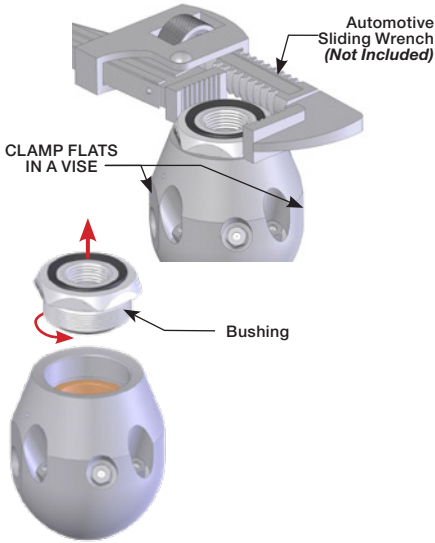

Figure 28: For Steps 1-2

3. Within the Switcher, there is a Poppet with a Spring beneath it. Push and turn the Poppet inwards until it can be removed. Set the Poppet and Spring aside.

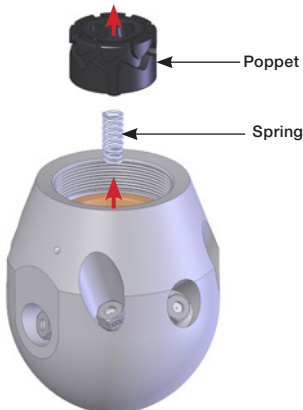

Figure 29: For Step 3

4. Remove the Front Jet from the Front Port with a 3/8" Nut Driver.

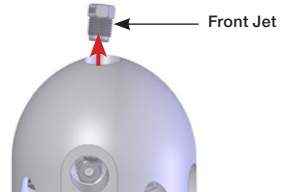

Figure 30: For Step 4

5. To remove the Cartridge Assembly from the Head, place the Head on the Arbor Press with the Front Port facing up. Locate the nose of the Cartridge Assembly through the Front Port. Insert a small punch to contact the nose inside the head and an Arbor Press to push down on the punch to release the Cartridge Assembly.

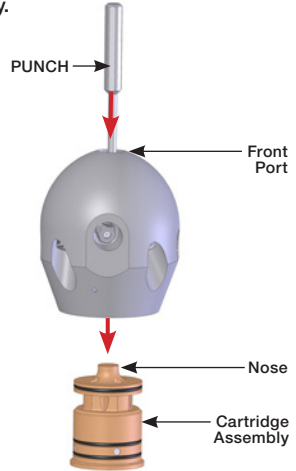

Figure 31: For Step 5

6. Use a pick to remove the O-Ring in the groove of the Bushing, and the three O-Rings on the Cartridge Assembly.

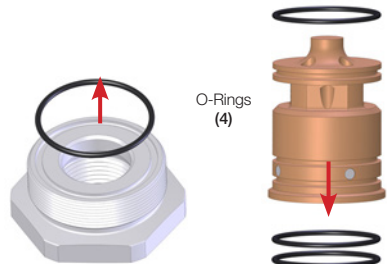

Figure 32: For Step 6

WHR SWITCHER ASSEMBLY

ASSEMBLY

NOTICE

If reusing parts instead of replacing them;

- Wash all parts thoroughly in solvent and blow dry before assembling.
- Clean any blockages or debris from the weep holes in the head with a pin.
- Inspect the Spring and the channels of the Poppet for wear.
- Inspect all O-Rings for wear and tearing.
- Inspect the threads of the Inlet Nut for wear.

GREASE = Lithium Complex NGLI 1 or Equal

ANTI-SEIZE = Swagelock® Blue Goop or Equal

1. To begin reassembling and the three O-Rings onto the Cartridge Assembly. Apply grease to all the O-Rings.

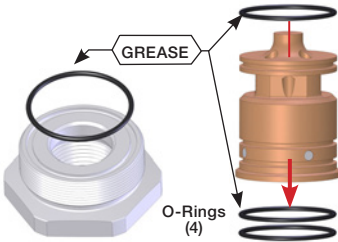

Figure 33: For Step 1

2. Install the prepped Front Jet into the Front Port with a 3/8" Nut Driver.
3. Use the small punch to press the Cartridge Assembly back into the Head. Use the Arbor Press on the punch to tap the Cartridge back into the Head evenly.

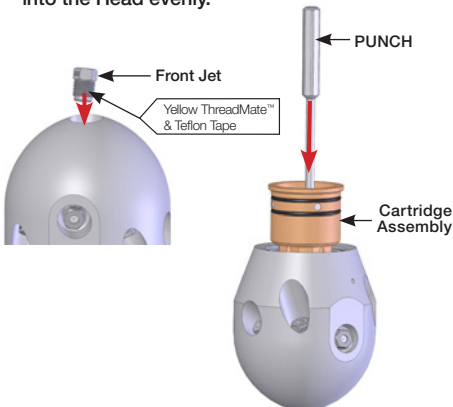

Figure 34: For Steps 2-3

4. Install the Spring into the center of the Cartridge Assembly.
5. Press the Poppet into the Head assembly and rotate while pressing until its held in place.

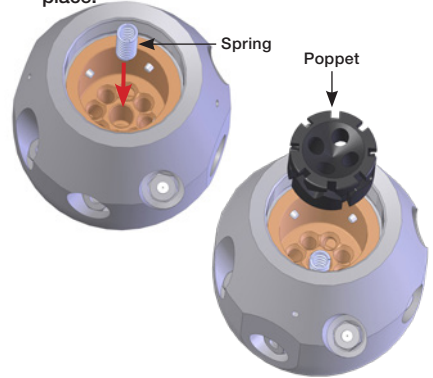

Figure 35: For Steps 4-5

6. Apply grease on and around the O-Ring in the Bushing.
7. Apply anti-seize to the threads of the Bushing, and begin to hand tighten it into the Head.
8. Secure the wrench flats of the Switcher Head in a vise with the Bushing facing up and securely tighten the Bushing to the Head with an Automotive Sliding Wrench, (Not Included)

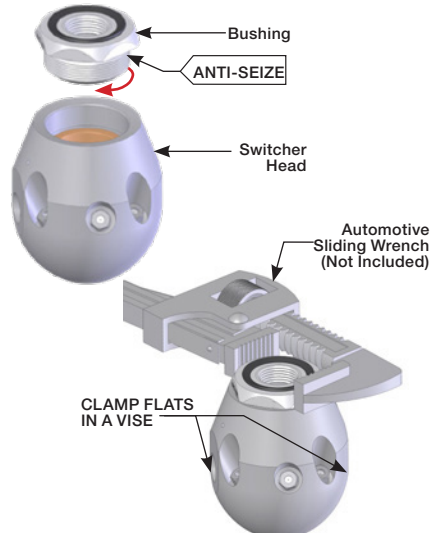
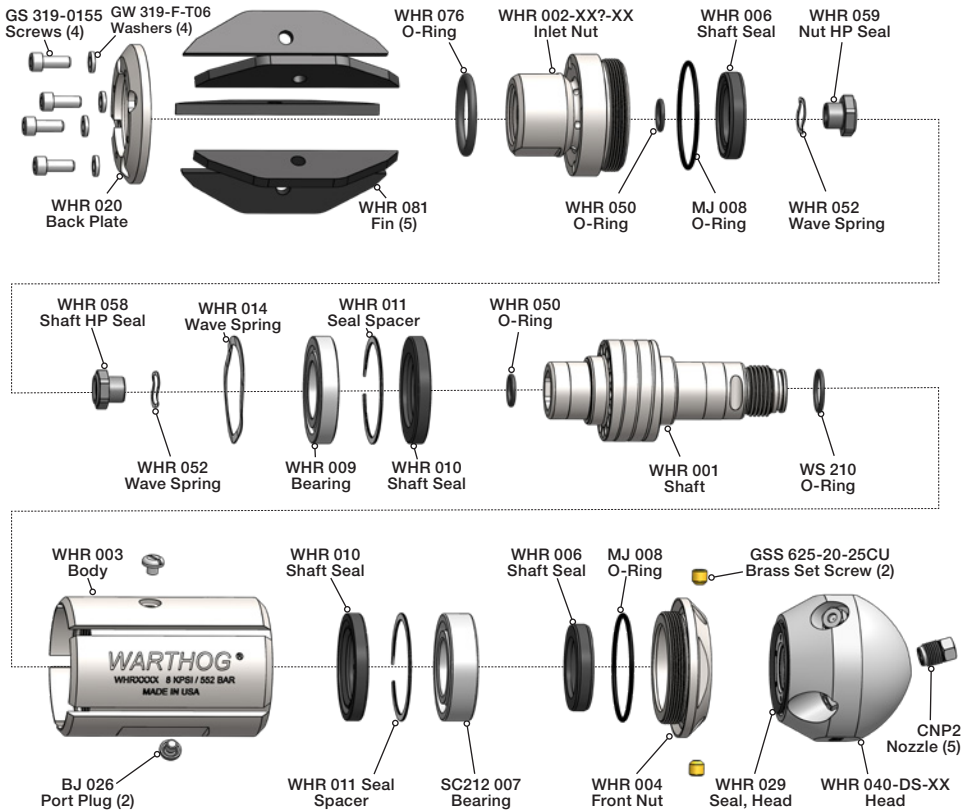

Figure 36: For Steps 6-8

WHR MAGNUM AND SWITCHER MAINTENANCE SCHEDULE

ITEM	FREQUENCY	MAINTENANCE REQUIRED
Nozzle	Weekly	<ul style="list-style-type: none"> Rinse the nozzle with clean water to remove debris between the head, body and shaft.
Inserts	Weekly	<ul style="list-style-type: none"> Inspect all inserts for blockages. Remove inserts with blockages and clean and dry them thoroughly. Use thread sealant and ensure inserts are not cross threaded when inserting them back into the head. Install the inserts back into the exact locations from which they were removed to ensure the nozzle remains balanced. If using the nozzle in recycled water, remove inserts and check for the following; Erosion or chipping of the orifice, missing or damaged flow straighteners, and/or visible damage to the insert itself.
Backplates	Weekly	<ul style="list-style-type: none"> Inspect the backplate screws. If the screws are loose, remove all of them and check screws, body, and threads are clean and dry.
Fins	Weekly	<ul style="list-style-type: none"> Inspect Fins for movement, wear (using wear indicators), and chips on the ends. If the fins are loose, remove all of them and check screws, body, and threads are clean and dry.
Head	Weekly	<ul style="list-style-type: none"> Ensure head is rotating properly; when turned by hand, head should turn free with slight, smooth resistance. If head spins too fast or sounds different than usual, nozzle may be low on viscous fluid or fluid is contaminated. If head feels gritty when turning, flush between head and body. If head still feels gritty when turning, rebuild recommended.
Insert Orifice Size	Every 6 months	<ul style="list-style-type: none"> Inspect insert orifice size with pin gages. Replace inserts as needed to retain most effective jetting capability and cleaning efficiency during operation.
Body	After one Year	<ul style="list-style-type: none"> See "Viscous Fluid Replacement" section of the User Manual. Flush viscous fluid with same type (BJ 048-M). This procedure is <i>only</i> recommended for replacing with the <i>same</i> fluid. Not all of the fluid will be replaced during the flushing procedure, therefore full disassembly and cleaning of the tool is recommended when changing to a different speed, or viscosity of fluid. Full fluid change is necessary when replacing bearings and shaft seals.
Nozzle	After two Years	<ul style="list-style-type: none"> Full disassembly, inspection, and overhaul. See complete Disassembly and Assembly instructions in the User Manual or Maintenance Video. (Links provided below.) Take care throughout the entire procedure to keep the internals clean and free from grit, lint, and contamination. Failure to do so could result in premature failure after service.

PART NAMES/NUMBERS AND SERVICE KITS



MAINTENANCE & OVERHAUL KITS

WHR 600 – SERVICE KIT

- 1 BJ 048-M Visc. Fluid, Med., 6oz
- 1 BJ 062-S Anti-seize, 2g
- 1 GP 049 Bearing Grease Syringe
- 4 GS 319-0155 Screws
- 4 GW 319-F-T06 Washers
- 2 GSS 625-20-25CU Set Screw
- 2 MJ 008 O-Ring
- 1 SC212 007 Bearing
- 1 WHR 006 Shaft Seal – Outer
- 1 WHR 009 Bearing
- 2 WHR 010 Shaft Seal – Inner
- 2 WHR 011 Seal Spacer
- 2 WHR 050 O-Ring
- 1 WHR 076 O-Ring
- 1 WS 210 Shaft O-Ring

WHR 602 – HP SEAL KIT

- 1 BJ 062-S Anti-seize, 2g
- 2 GP 805 Container, Round Lid
- 2 WHR 050 O-Ring
- 2 WHR 052 HP Seal Wave Spring
- 1 WHR 058 HP Seal – Shaft
- 1 WHR 059 HP Seal – Nut

WHR 610 – OVERHAUL KIT

- 2 BJ 026 Port Plug
- 1 BJ 048-M Visc Fluid., Med. 6oz
- 1 BJ 062-S Anti-seize, 2g
- 2 MJ 008 O-Ring
- 1 GP 025-P2SS Front Jet Plug
- 1 GP 049 Bearing Grease Syringe
- 2 GP 805 Container, Round Lid
- 4 GS 319-0155 Screws
- 4 GW 319-F-T06 Washers
- 1 SC212 007 Bearing
- 2 WHR 006 Shaft Seal – Outer
- 2 WHR 009 Bearing
- 2 WHR 010 Shaft Seal – Inner
- 2 WHR 011 Seal Spacer
- 1 WHR 014 Bearing Wave Spring
- 2 WHR 050 O-Ring
- 2 WHR 052 HP Seal Wave Spring
- 1 WHR 058 HP Seal – Shaft
- 1 WHR 059 HP Seal – Nut
- 1 WHR 076 Weep Seal O-Ring
- 1 WHR 180 Shaft Lock Pin
- 1 WS 210 O-Ring

WHR 612 – TOOL KIT

- 1 BA 481 Tool, Bearing Removal
- 1 WHR 180 Shaft Lock Pin
- 1 WHR 186 HP Seal Puller
- 1 WHR 181 Removal Press Tube
- 1 WHR 182 Installation Press Tube
- 1 WHR 183 Hex Tool
- 1 WHR 184 HP Seal Install Tool
- 1 WHR 187 Tool, HP Seal Puller Pin

PAGE LEFT BLANK INTENTIONALLY



TERMS AND CONDITIONS AND WARRANTY INFORMATION

1. Acceptance of Terms and Conditions. Receipt of these Terms and Conditions of Sale ("Terms and Conditions") shall operate as the acceptance by StoneAge, Inc. ("Seller") of the order submitted by the purchaser ("Buyer"). Such acceptance is made expressly conditional on assent by Buyer to these Terms and Conditions. Such assent shall be deemed to have been given unless written notice of objection to any of these Terms and Conditions (including inconsistencies between Buyer's purchase order and this acceptance) is given by Buyer to Seller promptly on receipt hereof.

Seller desires to provide Buyer with prompt and efficient service. However, to individually negotiate the terms of each sales contract would substantially impair Seller's ability to provide such service. Accordingly, the product(s) furnished by Seller are sold only according to the terms and conditions stated herein and with the terms and conditions stated in any effective StoneAge Dealer Agreement or StoneAge Reseller Agreement, if applicable. Notwithstanding any terms and conditions on Buyer's order, Seller's performance of any contract is expressly made conditional on Buyer's agreement to these Terms and Conditions unless otherwise specifically agreed to in writing by Seller. In the absence of such agreement, commencement of performance, shipment and/or delivery shall be for Buyer's convenience only and shall not be deemed or construed to be an acceptance of Buyer's terms and conditions.

2. Payment/Prices. Unless other arrangements have been made in writing between Seller and Buyer, payment for the product(s) shall be made upon receipt of invoice. The prices shown on the face hereof are those currently in effect. Prices invoiced shall be per pricelist in effect at the time of shipment. Prices are subject to increase for inclusion of any and all taxes which are applicable and which arise from the sale, delivery or use of the product(s), and the collection of which Seller is or may be responsible to provide to any governmental authority, unless acceptable exemption certificates are provided by Buyer in accordance with applicable law. Buyer shall pay all charges for transportation and delivery and all excise, order, occupation, use or similar taxes, duties, levies, charges or surcharges applicable to the product(s) being purchased, whether now in effect or hereafter imposed by any governmental authority, foreign or domestic.

3. Warranty. SELLER MAKES NO WARRANTIES OR REPRESENTATIONS AS TO THE PERFORMANCE OF ANY PRODUCT EXCEPT AS SET FORTH IN THE STONEAGE LIMITED WARRANTY PROVIDED WITH THE PRODUCT.

4. Delivery. Seller is not obligated to make delivery by a specified date, but will always use its best efforts to make delivery within the time requested. The proposed shipment date is an estimate. Seller will notify Buyer promptly of any material delay and will specify the revised delivery date as soon as practicable. UNDER NO CIRCUMSTANCES SHALL SELLER HAVE ANY LIABILITY WHATSOEVER FOR LOSS OF USE OR FOR ANY DIRECT OR CONSEQUENTIAL DAMAGES RESULTING FROM DELAY REGARDLESS OF THE REASON(S).

All product(s) will be shipped F.O.B. point of origin, unless specifically agreed otherwise, and Buyer shall pay all shipping costs and insurance costs from that point. Seller, in its sole discretion, will determine and arrange the means and manner of transportation of the product(s). Buyer shall bear all risk of loss commencing with the shipment or distribution of the product(s) from Seller's warehouse. Order shortages or errors must be reported within fifteen (15) business days from receipt of shipment to secure adjustment. No product(s) may be returned without securing written approval from Seller.

5. Modification. These Terms and Conditions are intended by Seller and Buyer to constitute a final, complete and exclusive expression of agreement relating to the subject matter hereof and cannot be supplemented or amended without Seller's prior written approval.

6. Omission. Seller's waiver of any breach or Seller's failure to enforce any of these Terms and Conditions at any time, shall not in any way affect, limit or waive Seller's right thereafter to enforce and compel strict compliance with every term and condition hereof.

7. Severability. If any provision of these Terms and Conditions is held to be invalid or unenforceable, such invalidity or unenforceability shall not affect the validity or enforceability of the other portions hereof.

8. Disputes. Seller and Buyer shall attempt in good faith to promptly resolve any dispute arising under these Terms and Conditions by negotiations between representatives who have authority to settle the controversy. If unsuccessful, Seller and Buyer shall further attempt in good faith to settle the dispute by nonbinding third-party mediation, with fees and expenses of such mediation apportioned equally to each side. Any dispute not so resolved by negotiation or mediation may then be submitted to a court of competent jurisdiction in accordance with the terms hereof. These procedures are the exclusive procedures for the resolution of all such disputes between the Seller and Buyer.

TERMS AND CONDITIONS AND WARRANTY INFORMATION

9. **Governing Law.** All sales, agreements for sale, offers to sell, proposals, acknowledgments and contracts of sale, including, but not limited to, purchase orders accepted by Seller, shall be considered a contract under the laws of the State of Colorado and the rights and duties of all persons, and the construction and effect of all provisions hereof shall be governed by and construed according to the laws of such state.

10. **Jurisdiction and Venue.** Seller and Buyer agree that the state or federal courts located within the City and County of Denver, Colorado shall have sole and exclusive jurisdiction over any litigation concerning any dispute arising under these Terms and Conditions not otherwise resolved pursuant to Section 9 as well as any alleged defects of any Products or damages sustained as a result of such alleged defects. Seller and Buyer further agree that should any litigation be commenced in connection with such a dispute, it shall only be commenced in such courts. Seller and Buyer agree to the exclusive jurisdiction of such courts and neither will raise any objection to the jurisdiction and venue of such courts, including as a result of inconvenience.

11. **Attorney's Fees.** If any litigation is commenced between Seller and Buyer, or their personal representatives, concerning any provision hereof, the party prevailing in the litigation shall be entitled, in addition to such other relief that is granted, to a reasonable sum as and for their attorneys' fees and costs in such litigation or mediation.

STONEAGE TRADEMARK LIST

View the list of StoneAge's trademarks and service marks and learn how the trademarks should be used. Use of StoneAge trademarks may be prohibited, unless expressly authorized.

<http://www.StoneAgetools.com/trademark-list/>

STONEAGE PATENT DATA

View the list of StoneAge's current U.S. patent numbers and descriptions.

<http://www.sapatents.com>

STONEAGE TERMS AND WARRANTY

View StoneAge's Terms and Warranty Conditions online.

<http://www.stoneagetools.com/terms>

<http://www.stoneagetools.com/warranty>

WARRANTY:

Warranties set forth herein extend only to End-Users, meaning customers acquiring, or that have previously acquired, a product manufactured by StoneAge ("Product") for their own use and not for resale, either directly from StoneAge Inc. ("StoneAge") or from a StoneAge Authorized Dealer or Reseller ("Dealer"). No warranty of any kind or nature is made by StoneAge beyond those expressly stated herein.

1. LIMITED WARRANTY PERIOD. Subject to the limitations and conditions hereinafter set forth, StoneAge warrants its Product to be free from defects in workmanship and material for a period of one (1) year from the date of purchase by the End-User, provided that the end of the limited warranty period shall not be later than eighteen (18) months from the date of shipment of the Product to the Dealer or the End-User by StoneAge ("Limited Warranty Period"). All replacement parts which are furnished under this Limited Warranty and properly installed shall be warranted to the same extent as the original Product under this Limited Warranty if, and only if, the original parts were found to be defective within the original Limited Warranty Period covering the original Product. Replacement parts are warranted for the remainder of the original Limited Warranty Period. This Limited Warranty does not cover any component part of any Product not manufactured by StoneAge. Any such component part is subject exclusively to the component manufacturer's warranty terms and conditions.

2. LIMITED WARRANTY COVERAGE. StoneAge's sole obligation under this Limited Warranty shall be, at StoneAge's option and upon StoneAge's inspection, to repair, replace or issue a credit for any Product which is determined by StoneAge to be defective in material or workmanship. StoneAge reserves the right to examine the alleged defective Product to determine whether this Limited Warranty is applicable, and final determination of limited warranty coverage lies solely with StoneAge. No statement or recommendation made by a StoneAge representative, Dealer or agent to End-User shall constitute a warranty by StoneAge or a waiver or modification to any of the provisions hereof or create any liability for StoneAge.

3. WARRANTY SERVICE PROVIDERS. Service and repair of the Product is to be performed only by StoneAge authorized service representatives, including Dealers who are authorized repair centers, with StoneAge approved parts. Information about StoneAge authorized service representatives can be obtained through the StoneAge website at www.stoneagetools.com/service. Unauthorized service, repair or modification of the Product or use of parts not approved by StoneAge will void this Limited Warranty. StoneAge reserves the right to change or improve the material and design of the Product at any time without notice to End-User, and StoneAge is not obligated to make the same improvements during warranty service to any Product previously manufactured.

4. WARRANTY EXCLUSIONS. This Limited Warranty does not cover, and StoneAge shall not be responsible for the following, or damage caused by the following: (1) any Product that has been altered or modified in any way not approved by StoneAge in advance in writing; (2) any Product that has been operated under more severe conditions or beyond the rated capacity specified for that Product; (3) depreciation or damage caused by normal wear and tear, failure to follow operation or installation instructions, misuse, negligence or lack of proper protection during storage; (4) exposure to fire, moisture, water intrusion, electrical stress, insects, explosions, extraordinary weather and/or environmental conditions including, but not limited to lightning, natural disasters, storms, windstorms, hail, earthquakes, acts of God or any other force majeure event; (5) damage to any Product caused by any attempt to repair, replace, or service the Product by persons other than StoneAge authorized service representatives; (6) costs of normal maintenance parts and services; (7) damage sustained during unloading, shipment or transit of the Product; or (8) failure to perform the recommended periodic maintenance procedures listed in the Operator's Manual accompanying the Product.

5. REQUIRED WARRANTY PROCEDURES. To be eligible for warranty service, the End-User must: (1) report the Product defect to the entity where the Product was purchased (i.e. StoneAge or the Dealer) within the Limited Warranty Period specified in this Limited Warranty; (2) submit the original invoice to establish ownership and date of purchase; and (3) make the Product available to a StoneAge authorized service representative for inspection to determine eligibility for coverage under this Limited Warranty. This Limited Warranty shall not extend to any person or entity who fails to provide proof of original purchase from StoneAge or a Dealer. No Product may be returned for credit or adjustment without prior written permission from StoneAge.

6. DISCLAIMER OF IMPLIED WARRANTIES AND OTHER REMEDIES. EXCEPT AS EXPRESSLY STATED HEREIN (AND TO THE FULLEST EXTENT ALLOWED UNDER APPLICABLE LAW), STONEAGE HEREBY DISCLAIMS ALL OTHER WARRANTIES, EXPRESS OR IMPLIED, INCLUDING WITHOUT LIMITATION ALL IMPLIED WARRANTIES OF MERCHANTABILITY OR FITNESS FOR A PARTICULAR PURPOSE, AND ANY AND ALL WARRANTIES, REPRESENTATIONS OR PROMISES AS TO THE QUALITY, PERFORMANCE OR FREEDOM FROM DEFECT OF THE PRODUCT COVERED BY THIS LIMITED WARRANTY. STONEAGE FURTHER DISCLAIMS ALL IMPLIED INDEMNITIES.

TERMS AND CONDITIONS AND WARRANTY INFORMATION

7. LIMITATION OF LIABILITY. End-User specifically acknowledges that the Product may be operated at high speeds and/or pressures, and that as such it may be inherently dangerous if not used correctly. End-User shall familiarize itself with all operation materials provided by StoneAge and shall at all times use and require its agents, employees and contractors to use all necessary and appropriate safety devices, guards and proper safe operating procedures. In no event shall StoneAge be responsible for any injuries to persons or property caused directly or indirectly by the operation of the Product if End-User or any agent, employee, or contractor of End-User: (1) fails to use all necessary and appropriate safety devices, guards and proper safe operating procedures; (2) fails to maintain in good working order such safety devices and guards; (3) alters or modifies the Product in any way not approved by StoneAge in advance in writing; (4) allows the Product to be operated under more severe conditions or beyond the rated capacity specified for the Product; or (5) otherwise negligently operates the Product. End-User shall indemnify and hold StoneAge harmless from any and all liability or obligation incurred by or against StoneAge, including costs and attorneys' fees, to or by any person so injured.

TO THE FULL EXTENT ALLOWED BY APPLICABLE LAW, STONEAGE SHALL NOT BE LIABLE FOR ANY INDIRECT, SPECIAL, INCIDENTAL, CONSEQUENTIAL, OR PUNITIVE DAMAGES (INCLUDING WITHOUT LIMITATION, LOSS OF PROFITS, LOSS OF GOODWILL, DIMINUTION OF VALUE, WORK STOPPAGE, INTERRUPTION OF BUSINESS, RENTAL OF SUBSTITUTE PRODUCT, OR OTHER COMMERCIAL LOSS EVEN TO THE EXTENT SUCH DAMAGES WOULD CONSTITUTE DIRECT DAMAGES), WITH RESPECT TO THE COVERED STONEAGE PRODUCT, OR OTHERWISE IN CONNECTION WITH THIS LIMITED WARRANTY, REGARDLESS OF WHETHER STONEAGE HAS BEEN ADVISED OF THE POSSIBILITY OF SUCH DAMAGES.

IT IS UNDERSTOOD THAT STONEAGE'S LIABILITY, WHETHER IN CONTRACT, IN TORT, UNDER ANY WARRANTY, IN NEGLIGENCE, OR OTHERWISE SHALL NOT EXCEED THE AMOUNT OF THE PURCHASE PRICE PAID BY THE END-USER FOR THE PRODUCT. STONEAGE'S MAXIMUM LIABILITY SHALL NOT EXCEED, AND END-USER'S REMEDY IS LIMITED TO EITHER (1) REPAIR OR REPLACEMENT OF THE DEFECTIVE WORKMANSHIP OR MATERIAL OR, AT STONEAGE'S OPTION, (2) REFUND OF THE PURCHASE PRICE, OR (3) ISSUANCE OF A CREDIT FOR THE PURCHASE PRICE, AND SUCH REMEDIES SHALL BE END-USER'S ENTIRE AND EXCLUSIVE REMEDY.

YOU, THE END-USER, UNDERSTAND AND EXPRESSLY AGREE THAT THE FOREGOING LIMITATIONS ON LIABILITY ARE PART OF THE CONSIDERATION IN THE PRICE OF THE STONEAGE PRODUCT YOU PURCHASED.

Some jurisdictions do not allow the limitation or exclusion of liability for certain damages, so the above limitations and exclusions may not apply to you. This Limited Warranty gives you specific legal rights, and you may also have other rights which vary from jurisdiction to jurisdiction. If any provisions of this Limited Warranty is held to be invalid or unenforceable, such invalidity or unenforceability shall not affect the validity or enforceability of the other portions hereof.



1-866-795-1586 • www.STONEAGETOOLS.com

© 2021 StoneAge, Inc. All Rights Reserved