

# OWNER'S MANUAL

## Model: LG-15-EC (5301302) (15 Gallon Lawn & Garden Spot Sprayer)

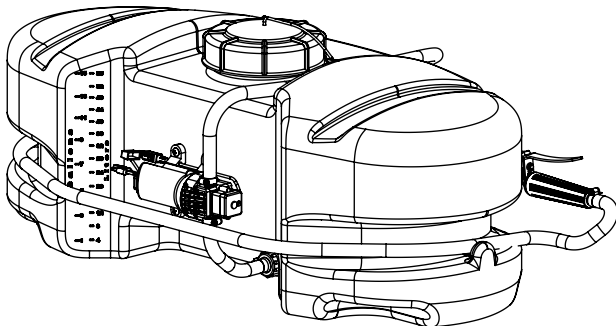

BEFORE RETURNING THIS PRODUCT  
FOR ANY REASON, PLEASE CALL

**1-800-831-0027**

IF YOU SHOULD HAVE A QUESTION OR  
EXPERIENCE A PROBLEM WITH YOUR  
FIMCO INDUSTRIES PRODUCT:

**1-800-831-0027**

BEFORE YOU CALL, PLEASE HAVE THE  
FOLLOWING INFORMATION AVAILABLE:  
SALES RECEIPT & MODEL NUMBER. IN MOST  
CASES, A FIMCO INDUSTRIES EMPLOYEE CAN  
RESOLVE THE PROBLEM OVER THE PHONE.

### General Information

Thank you for purchasing this product. The purpose of this manual is to assist you in operating and maintaining your lawn & garden spot sprayer. Please read it carefully, as it furnishes information which will help you achieve years of trouble-free operation.

#### Things to know about your sprayer:

1. The threaded inserts at the bottom of the tank are 5/16" coarse thread.
2. Drain plug threads are 3/4" Garden Hose Thread (GHT)
3. Pump (open-flow) output is 1.0 g.p.m.

### Warranty/Parts/Service

For home usage, products are warranted for one year from date of purchase against manufacturer or workmanship defects.

Commercial users have a 90 day warranty.

Your authorized dealer is the best source of replacement parts and service. To obtain prompt, efficient service, always remember to give the following information...

- Correct Part Description and/or part number.
- Model number/Serial number of your sprayer.

Part descriptions and part numbers can be obtained from the illustrated parts list section(s) of this manual.

Whenever you need parts or repair service, contact your distributor/dealer first. For warranty work, always take your original sales slip, or other evidence of purchase date, to your distributor/dealer.

### Assembly

Your sprayer has been mostly assembled at the factory. The only requirement will be for you to hook up your battery leads to a fully charged 12 Volt battery. The red wire must be connected to the "hot" lead, and the black wire should be connected to the ground.

If you choose to strap your tank down with straps, do not over-tighten your straps, this could cause the tank to bow slightly. Sometimes a simple platform (a board of some sort, perhaps) can be fabricated to accommodate your tank. If mounted this way, securing the tank to this platform from the underside would be the desired way of attachment.

#### NOTE:

**It is VERY important for you to test your sprayer with plain water before actual spraying is attempted. This will enable you to check the sprayer for leaks, without the possibility of losing any expensive chemicals.**

### Operation

Your sprayer is equipped with (2) ON/OFF switches. One is on the wire assembly that you hook up to your battery, the other is on the pump itself, on the opposite end of the pressure switch. The "-" is the "ON" position and the "o" is the "OFF" position for both switches. Make sure both switches are depressed in the "-" position for operation.

In addition to the ON/OFF switch, the pump is equipped with an electronic pressure switch that is factory pre-set for it to shut off at 35 p.s.i.. This switch assembly is the 'square box' on the head portion of the pump.

Always fill the tank with a desired amount of water first, and then add the chemical slowly, mixing as you pour the chemical into the tank. You may use the handgun to spray into the solution in order to mix the chemical and water.

Initially begin spraying by opening the handgun. This will enable the air in the line to be purged through the handgun tip, while building pressure.

The pumping system draws solution from the tank, through the strainer/filter, and to the pump. The pump forces the solution under pressure to the handgun and/or boom nozzles.

- Open the handgun by squeezing the handle lever.
- Rotating the adjustable nozzle tip on the handgun will change the tip pattern from a straight stream to a cone pattern (finer mist).



[www.fimcoindustries.com](http://www.fimcoindustries.com)

1000 FIMCO Lane, P.O. Box 1700, North Sioux City, SD 57049  
Toll Free Phone: 800-831-0027 : Toll Free Fax: 800-494-0440

Form No. 1283 [5004778 (03/11)] Printed in the U.S.A.

After testing, add water and chemical to the tank. Adjust the pressure and spray as you did in the testing procedure. Conditions of weather and terrain must be considered when setting the sprayer. Do not spray on windy days. Protective clothing must be worn in some cases.

**Be sure to read the chemical label(s) correctly!**

## Technical Specifications

- 15 Gal. Corrosion-Resistant Polyethylene Tank
- 12 Volt Diaphragm Pump, 1.0 g.p.m.
- 15 Ft. Handgun Hose
- 18 Ft. max. vertical throw, 30 Ft. max. horizontal throw

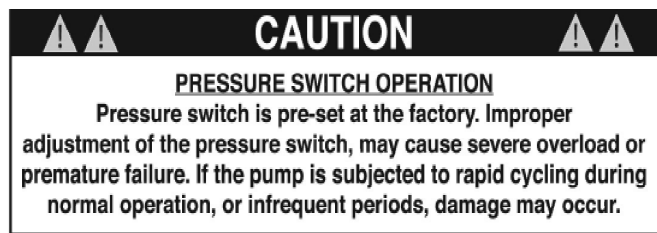
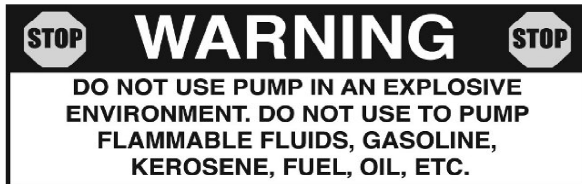

## After Spraying

After use, fill the sprayer tank part way with water. Start the sprayer, and allow the clear water to be pumped through the plumbing system and out through the spray nozzles. Refill the tank about half full with plain water and use FIMCO Tank Neutralizer and Cleaner, and repeat cleaning instructions above.

Flush the entire sprayer with the neutralizing/cleaning agent, then flush out one more time with plain water. Follow the chemical manufacturer's disposal instructions of all wash or rinsing water.

For the boom, (if applicable) remove the tips and screens from the nozzle assemblies. Wash these items out thoroughly. Blow the orifice clean and dry. If the orifice remains clogged, clean it with a fine bristle (NOT WIRE) brush, or with a toothpick. Do not damage the orifice. Water rinse and dry the tips before storing.

**WARNING: Some chemicals will damage the pump valves if allowed to soak untreated for a length of time! ALWAYS flush the pump as instructed after each use.**

## Winter Storage

Drain all water out of sprayer, paying special attention to the pump, handgun, and valve(s). These items are especially prone to damage from chemicals and freezing weather.

The sprayer should be winterized before storage, by pumping a solution of RV Antifreeze through the entire plumbing system. This antifreeze solution should remain in the plumbing system during the winter months. When spring time comes and you are preparing your sprayer for the spray season, rinse the entire plumbing system out, clearing the lines of the antifreeze solution. Proper care and maintenance will prolong the life of your sprayer.

## #5275702 Pump

### Troubleshooting a 1.0 g.p.m. Pump:

(12 Volt, 4 Amp, 1.0 gpm, 35 psi)

Pump will NOT run:

- Check inline fuse on the wires on the pump. If blown, replace with new fuse. (5 Amp mini-blade fuse...#5157204)
- Make sure BOTH on/off switches are in the 'on' position (-).
- Make sure you 12 volt source (battery) is fully charged.
- Insure a tight connection at the battery clips.

If none of the above will work, try pulling wire terminal "A" off of the spade terminal of the pressure switch, and cross it over and touch terminal "B". (You will need to remove the pressure switch cap before doing this) If your pump runs when you do this, you know you will need to replace your pressure switch.

Another thing you can try is to take apart the switch box on the lead wire assembly (#5274443) with the (2) phillips head screws, and 'hot-wire' it together. Take the (2) wires that are screwed to the rocker switch, off of the switch and twist them together. This will insure you are getting the full 12 volts to the pump. If your pump runs after doing this, you will know that your lead wire assembly needs to be replaced.

Pump runs, but does not prime:

- Check line strainer (screen) at the inlet location, at the tank. You will need to unscrew the knurled nut to access this screen. (see exploded view later in this manual) The tank should be empty while performing this, otherwise you may need to tilt the tank backwards a little bit so any solution in the tank will be away from this inlet location. Periodically take the screen at this location out and clean it.
- Unscrew (2) screws "S". This will allow you to inspect the bearing and counterweight.
- Both the counterweight and the bearing need to spin freely, and they both need to spin INDEPENDENT of each other. If these 2 pieces are 'stuck' together, you will need to break them free with some good quality lubricant or something similar and this should restore most of your prime.

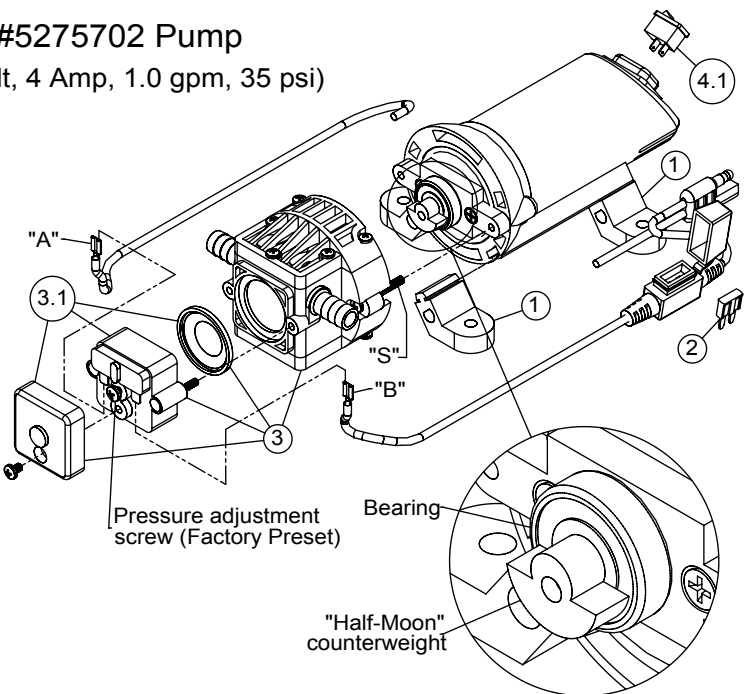

Item No	Part Number	Qty	Description	List Price
1	5095202	1	Pump Foot (Pkg. of 4)	4.99
2	5157204	1	5 Amp Mini Fuse	3.99
3	5275531	1	Pump Assembly w/Pressure Switch	37.95
3.1	5157201	1	Pressure Switch w/Diaphragm	23.95
4.1	5157207	1	Rocker Switch	6.99

## Exploded View/Parts List: LG-15-EC (5301302)

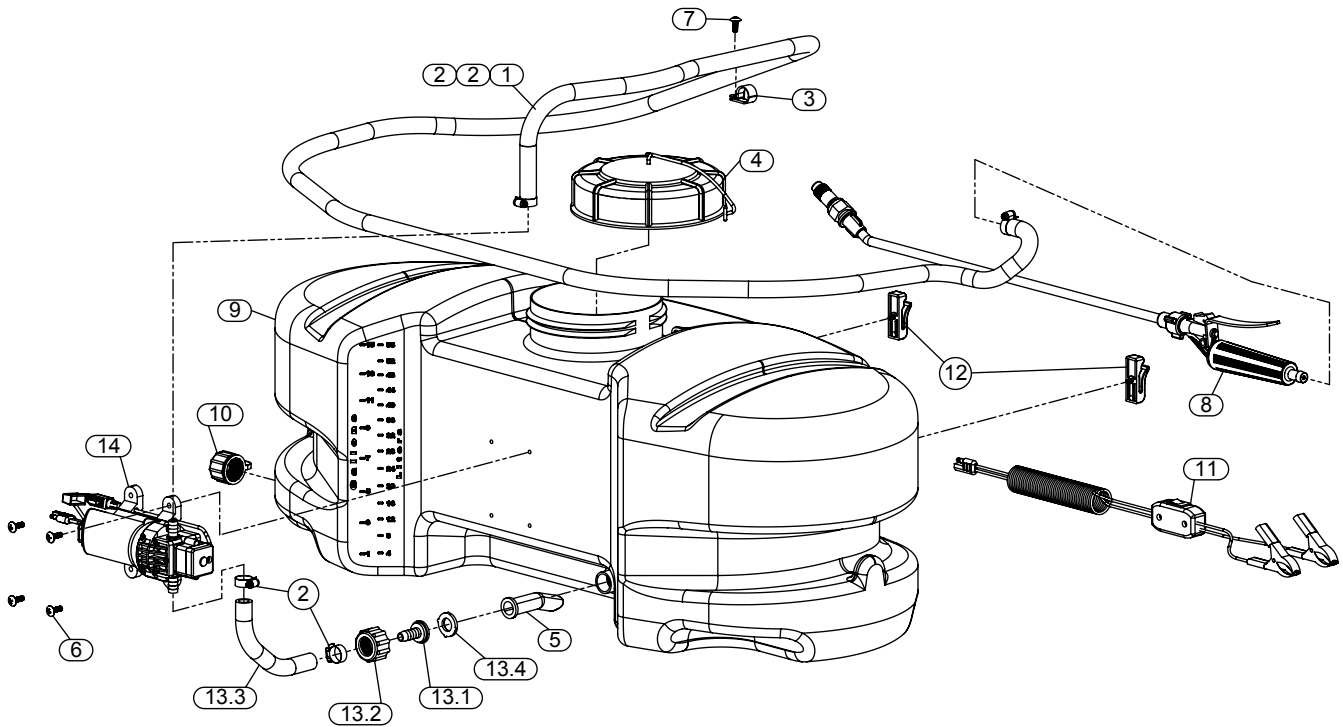

Approximate Unit Dimensions:  
 Length = 35"  
 Width = 17"  
 Height = 14"

Item No	Part Number	Qty	Description	List Price
1	5020215	1	Hose, 3/8"-1 Brd. x 15 Ft.	10.35
2	5051114	4	Hose Clamp (3/8"-1/2")	.63
3	5051122	1	5/8" Black Nylon Loom Cable Clamp	.25
4	5058188	1	Tank Lid w/Lanyard	10.50
5	5100452	1	Siphon Tube	1.20
6	5117167	4	#10-24 x 5/8" Phillips Truss Head Machine Screw	.25
7	5117234	1	#10-24 x 1/2" Phillips Truss Head Machine Screw	.25
8	5163100	1	Low-Flow Handgun w/X-26 Tip	9.95
9	5169242	1	15 Gallon (New Style) Tank	50.00
10	5274373	1	Drain Plug Cap, Tether, and Washer Assembly	2.95
11	5274443	1	Lead Wire Assembly (w/Switch), 96"	9.99
12	5274880	1	Pkg. (2) Handgun Clips & (2) Screws	2.85
13	5275511	1	Inlet Sub-Assembly (EC Units)	5.00
13.1	5149034	1	Poly Swivel, 3/8" Hose Barb	.65
13.2	5006209	1	Poly Knurled Swivel Nut, 3/4" FGHT	.71
13.3	5020095	1	Hose, 3/8"-1 Brd. x 6 1/2"	.86
13.4	5116242	1	Strainer, 1" Filter Washer	.31
14	5275702	1	Gold Series 1.0 g.p.m. Pump	89.00

(List Prices are Subject to Change)